

THIS DRAWING IS UNPUBLISHED. RELEASED FOR PUBLICATION
 © COPYRIGHT - By - ALL RIGHTS RESERVED.

LOC		DIST		REVISIONS			
P	LTR	DESCRIPTION		DATE	DWN	APVD	
CM	00	P1		REVISED PER ECO-11-004820	11MAR11	RK HMR	

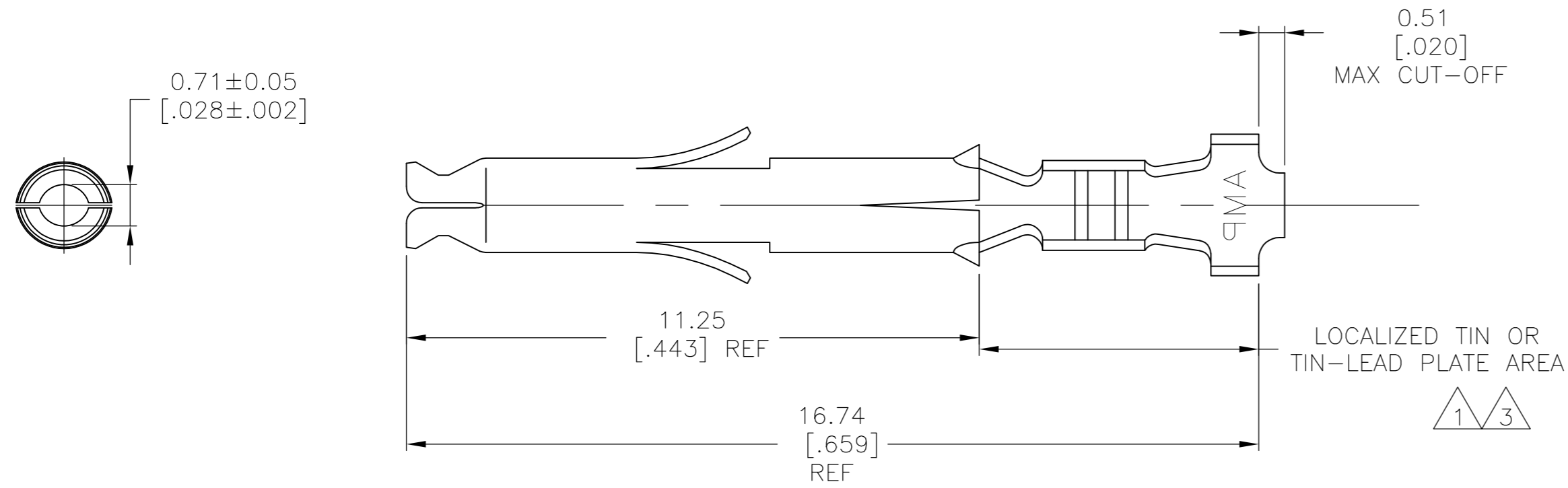

- 1 0.00076 [.000030] MIN GOLD IN LOCALIZED GOLD PLATE AREA AND 0.00254 [.000100] MIN BRIGHT TIN-LEAD IN LOCALIZED TIN-LEAD PLATE AREA OVER 0.0013 [.000050] MIN NICKEL.
- 2. WIRE RANGE: 0.5-0.15 mm²(30-26 AWG)
- 3 0.00076 [.000030] MIN GOLD IN LOCALIZED GOLD PLATE AREA AND 0.00254 [.000100] MIN MATTE TIN IN LOCALIZED TIN PLATE AREA OVER 0.0013 [.000050] MIN NICKEL.

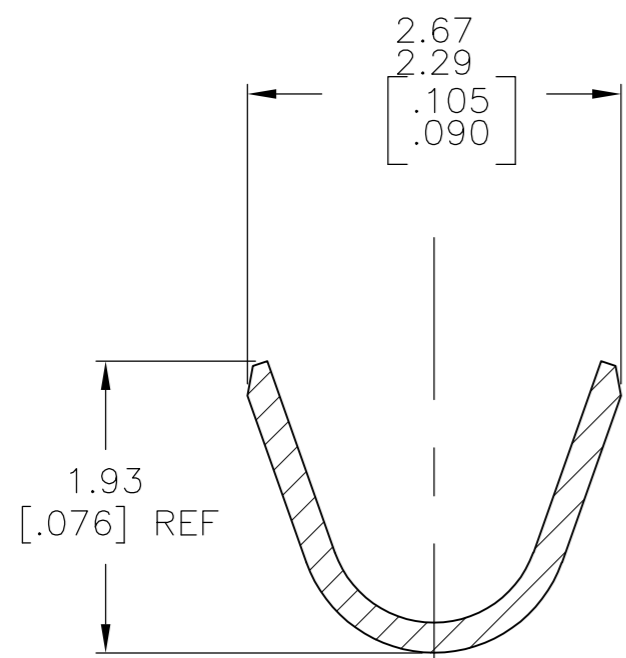
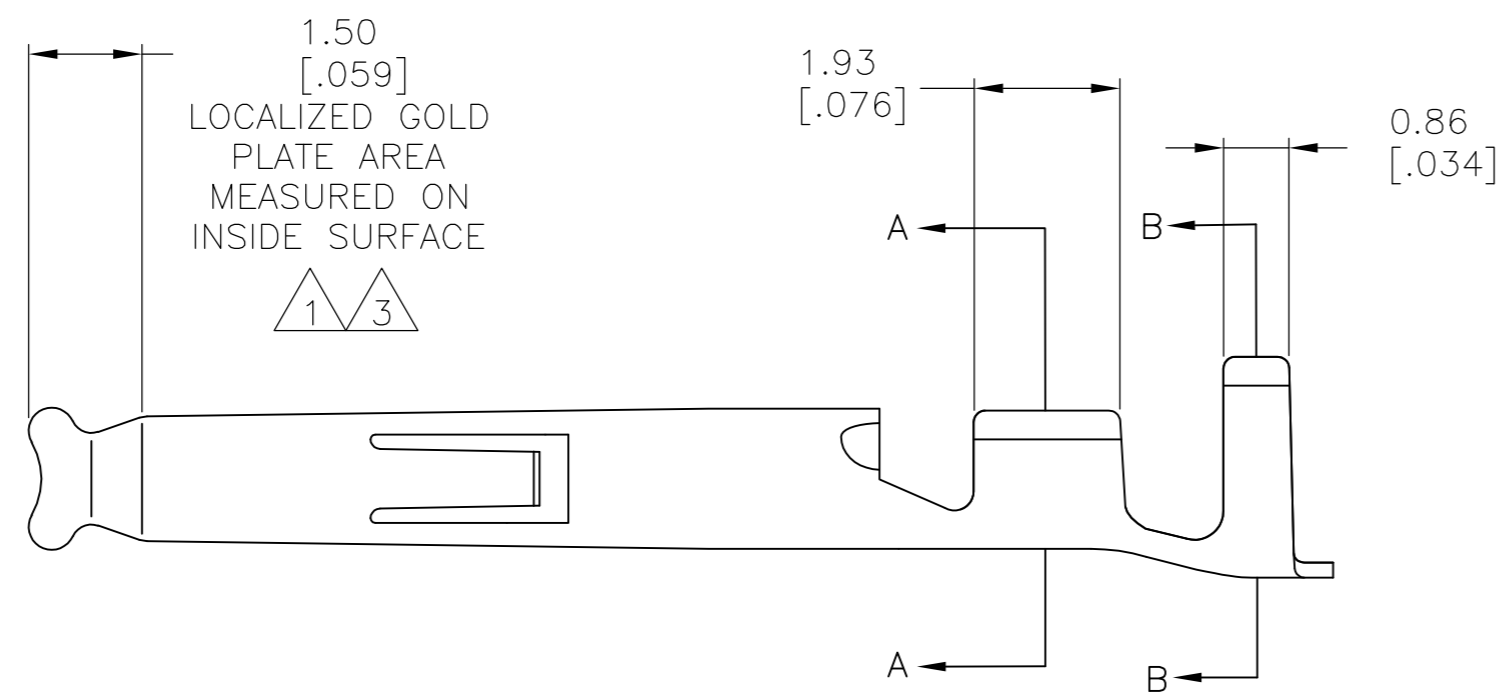

SECTION B-B
SCALE 20:1

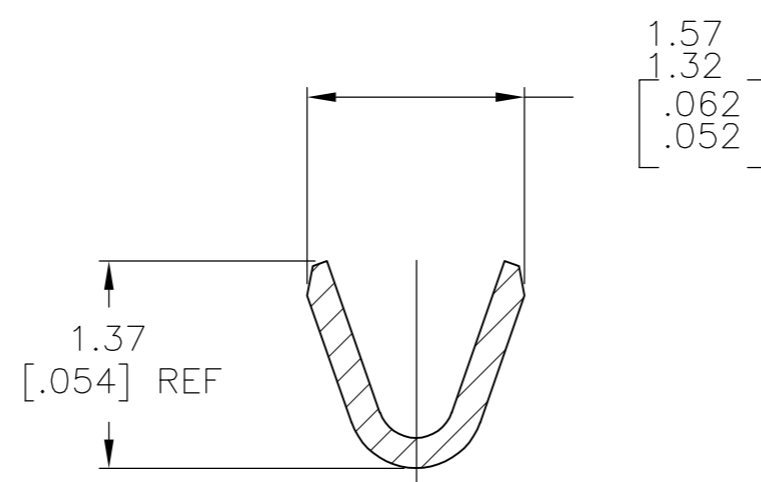

SECTION A-A
SCALE 20:1

FINISH	MATERIAL	PART NUMBER
3	0.20 [.008] PH BRZ	1-770834-1
3	0.20 [.008] BRASS	1-770834-0
1	0.20 [.008] PH BRZ	770834-6
PRE-TIN	0.20 [.008] PH BRZ	770834-4
1	0.20 [.008] BRASS	770834-3
PRE-TIN	0.20 [.008] BRASS	770834-1

THIS DRAWING IS A CONTROLLED DOCUMENT.		DWN S. HOOVER 17OCT02	TE TE Connectivity	
DIMENSIONS: mm [INCHES]		CHK C. JONES 17OCT02		
TOLERANCES UNLESS OTHERWISE SPECIFIED:		APVD C. JONES 17OCT02	NAME	
0 PLC ± -		PRODUCT SPEC	SOCKET, MINI UNIVERSAL MATE-N-LOK(TM)	
1 PLC ± -		APPLICATION SPEC	SIZE A2	CAGE CODE 00779
2 PLC ± -		WEIGHT -	DRAWING NO C=770834	RESTRICTED TO -
3 PLC ± 0.15[.006]		CUSTOMER DRAWING	SCALE 10:1	SHEET 1 of 1
4 PLC ± -			REV P1	
ANGLES ± 1°				
FINISH -				

METRIC