

THIS DRAWING IS UNPUBLISHED. RELEASED FOR PUBLICATION
 © COPYRIGHT BY TYCO ELECTRONICS CORPORATION. ALL RIGHTS RESERVED.

LOC	DIST	REVISIONS					
AG	53	P	LTR	DESCRIPTION	DATE	DWN	APVD
		0		RELEASED	26JAN06	JDP	JGH

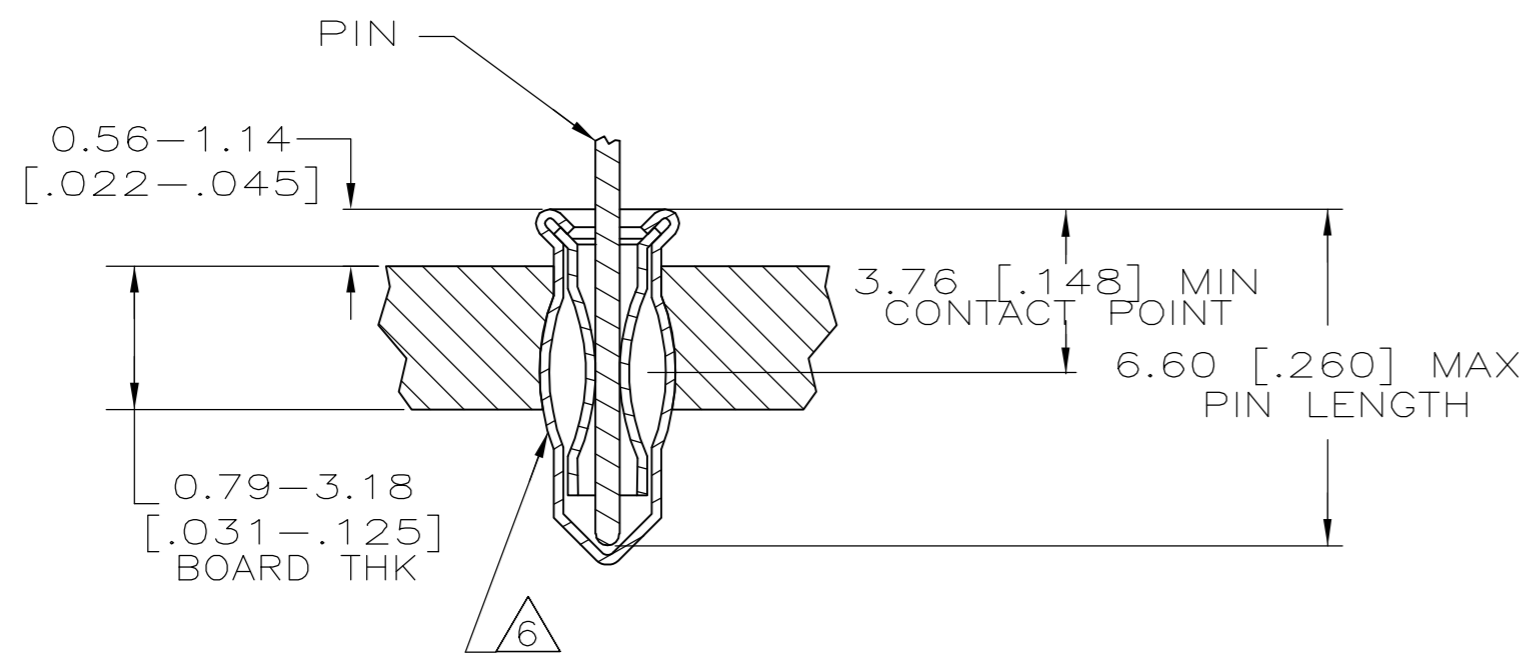
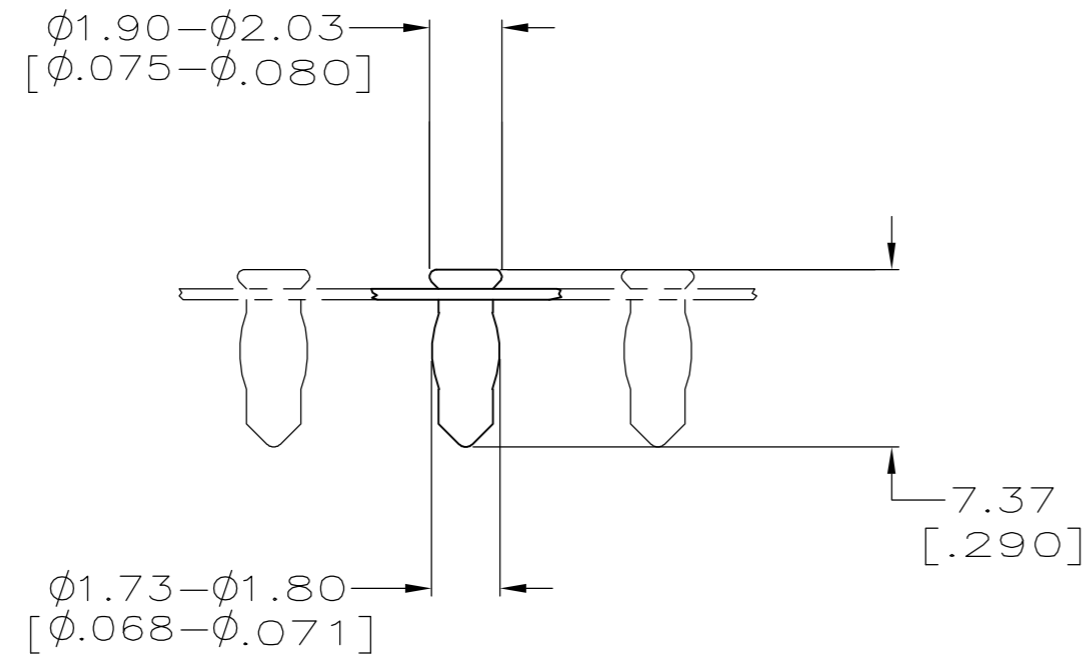
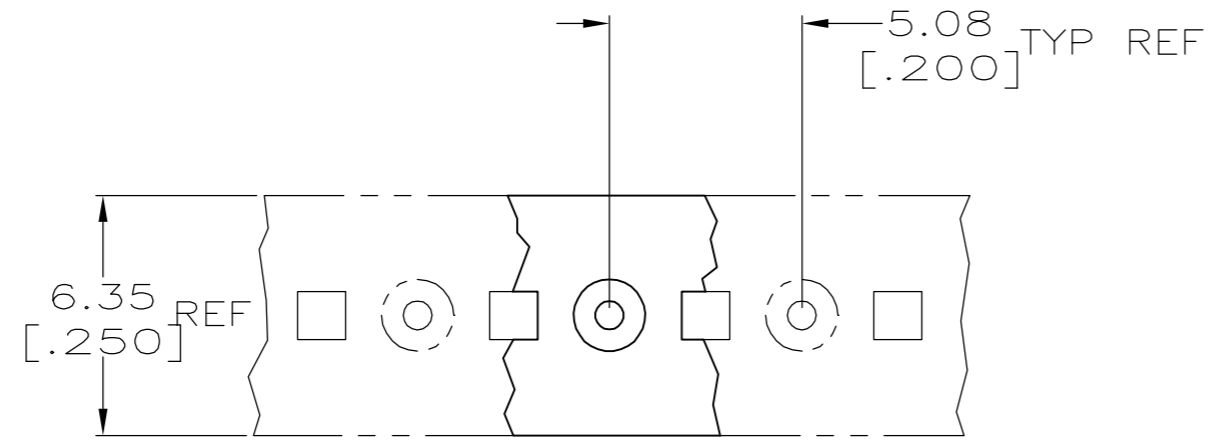

- 1 MATERIAL:
EYELET - COPPER PER ASTM B 152
SPRING - BERYLLIUM COPPER PER ASTM B 194
- 2 TIN PLATE PER ASTM B 545, 0.00254 [.000100] MIN THK.
- 3 GOLD PLATE PER ASTM B 488, 0.00076 [.000030] MIN THK ON CONTACT AREA.
- 4. PACKAGED 10,000 PER REEL
- 5 TO INSURE 1/2 OZ MIN RETENTION DO NOT EXCEED 0.10 [.004] DIFFERENCE IN PIN DIA WHEN CHANGING TO A SMALLER DIA PIN
- 6 PRODUCT IS OVALIZED FOR RETENTION IN THE P.C. BOARD. THE RECOMMENDED HOLE DIAMETER IS $\phi 1.57$ [$\phi 0.062$] MINIMUM, +0.08 [.003] MAX. PRIOR TO SOLDERING.

3.76-6.60 [.148-.260]	$\phi 0.71 - \phi 0.84$ [$\phi 0.028 - \phi 0.033$]	GOLD 3	TIN 2	1-5645990-2
3.76-6.60 [.148-.260]	$\phi 0.71 - \phi 0.84$ [$\phi 0.028 - \phi 0.033$]	TIN 2	TIN 2	1-5645990-1
LENGTH	DIA	SPRING	EYELET	PART NO

THIS DRAWING IS A CONTROLLED DOCUMENT.		DWN J. POLIGNONE 26JAN06	Tyco Electronics Corporation Harrisburg, PA 17105-3608	
DIMENSIONS: mm [INCHES]		CHK J. HAVENER 26JAN06	NAME MINIATURE SPRING SOCKET ASSY SERIES 3 WITHOUT SEALANT	
TOLERANCES UNLESS OTHERWISE SPECIFIED:		APVD J. HAVENER 26JAN06	SIZE A2	CAGE CODE 00779
0 PLC ± -		PRODUCT SPEC 108-14008	DRAWING NO C=5645990	RESTRICTED TO -
1 PLC ± -		APPLICATION SPEC 114-26004	SCALE 10:1	SHEET 1 of 1
2 PLC ± -		WEIGHT -	REV 0	
3 PLC ± 0.20[.008]		CUSTOMER DRAWING		
4 PLC ± -				
ANGLES ± -				
FINISH SEE TABLE				