

REVISIONS			
REV	DESCRIPTION	DATE	APPROVED
02 <sub>1</sub>	REVISED	B.M.N. 7/11/86	RAC

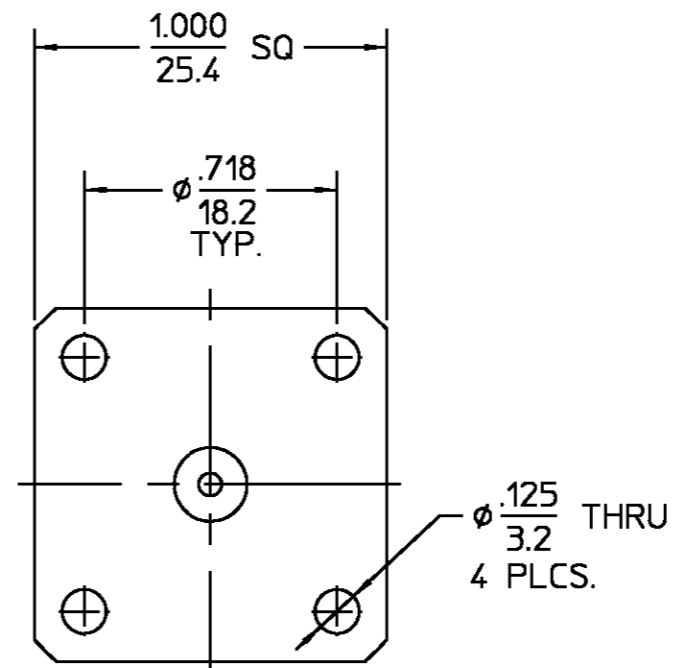
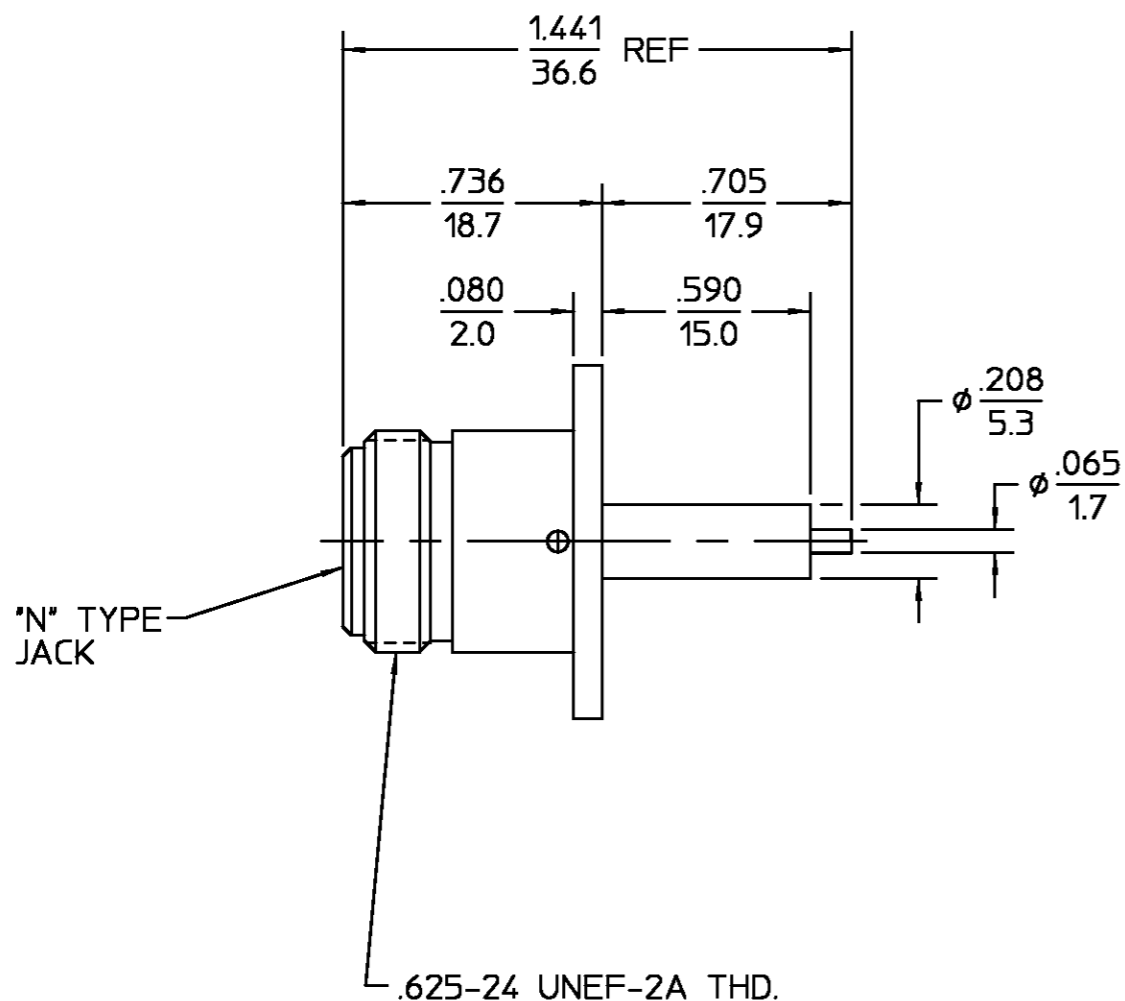

HOUSING	STAINLESS STEEL PER ASTM-A484 AND ASTM-A582, TYPE 303	PASSIVATE PER QQ-P-35
DIELECTRIC	TFE FLUOROCARBON PER ASTM-D-1457	N/A
CENTER CONTACT	BERYLLIUM COPPER PER ASTM-B-196 OR ASTM-B-197, ALLOY C17300, CONDITION H	GOLD PLATE PER MIL-G-45204
COMPONENT	MATERIAL	FINISH

UNLESS OTHERWISE SPECIFIED DIMENSIONS ARE IN INCHES	DRAWN BY E.S.	DATE 12/6/77	<b>AMP</b> AMP Incorporated 140 Fourth Avenue Waltham, MA 02451-7599	
	CHECKED BY K.W.	12/21/77		
FRAC. ± 1/64	DEC. ± .005	ANGLES ± 1°		
These drawings and specifications are the property of M/A COM Interconnect Div. and shall not be reproduced or copied or used in whole or in part as the basis for the manufacture or sale of item(s) without written permission.			3652-1201-02 SHEET 1 OF 1	

NOTES:  
1. CAPTURED CENTER CONTACT

.XXX = in  
XX.X = mm (REF)

CUSTOMER DRAWING

AMP PART # 1058644-1  
SHEET 1 OF 1 REV A