



TABLE OF CONTENTS

SECTION	PAGE
1.0 SCOPE.....	2
2.0 APPLICABLE DOCUMENTS AND SPECIFICATIONS.....	2
3.0 RATINGS.....	2
4.0 ELECTRICAL PERFORMANCE	3
5.0 MECHANICAL PERFORMANCE	4
6.0 ENVIRONMENTAL PERFORMANCE	5-6
7.0 TEST GROUPING'S	7
APPENDICES, RECOMMENDED TEST METHODS.....	8-15

REV.		J																	
SHEET	1	TO	15																

REVISE ON PC ONLY:		TITLE:	PRODUCT SPECIFICATION FOR 2.54mm SIM Conn SMT						
J	ADDED OPTION		THIS DOCUMENT CONTAINS INFORMATION THAT IS PROPRIETARY TO MOLEX INC. AND SHOULD NOT BE USED WITHOUT WRITTEN PERMISSION						
	DC 05/08/2010 ECN E2010-0407								
REV.	DESCRIPTION		WRITTEN BY:	CHECKED BY:	APPROVED BY	DATE:	YR/MO/DAY		
	DESIGN CONTROL	STATUS	FDUGGAN			2004/05/04			
	MXI					FILENAME		SHEET	
	DOCUMENT NUMBER				PS-99020		1 of 15		
	PS-99020-0071								



1.0 SCOPE

This specification defines the performance of the 2.54 mm pitch SIM PCB connector 91228, and mating card holders 91236 and 91356 for usage with the Plug-in SIM as specified by the GSM 11.11 Version 5.3.0: July 1999 specification.

NOTE: Normal force at maximum deflection see Test Ref. 5.10.

2.0 APPLICABLE DOCUMENTS AND SPECIFICATIONS

See sales drawing and other sections of this specification for the relevant reference documents and specifications. In cases where the specification differs from the product drawings, the product drawings take precedence.

Description	Document
SIM PCB connector	SDA-91228, SDA-91228-008, SDA-91228-010, SDA-91228-011, SDA-91228-012 SD-91228-001, RSD-91228-008, RSD-91228-010 RSD-91228-011, RSD-91228-012 RSD-91980-010, RSD-92201-047, RSD-92201-048
Card Holder	SDA-91236, SDA-91236-006, SDA-91236-009, SD-91356-001 RSD-91236-008, RSD-91236-010, RSD-91236-015

3.0 RATINGS

3.1	Current	0.5 Amp maximum per contact
3.2	Voltage	50 V DC (maximum)
3.3	Durability	5000 mating cycles
3.4	Operating temperature range	-40°C to +85°C
3.5	Storage temperature range	-40°C to +90°C

REVISE ON PC ONLY:		TITLE:	PRODUCT SPECIFICATION FOR 2.54mm SIM Conn SMT	
J	SEE SHEET 1	THIS DOCUMENT CONTAINS INFORMATION THAT IS PROPRIETARY TO MOLEX INC. AND SHOULD NOT BE USED WITHOUT WRITTEN PERMISSION		
REV.	DESCRIPTION			
DOCUMENT NUMBER PS-99020-0071		FILENAME PS-99020	SHEET 2 of 15	



4.0 ELECTRICAL PERFORMANCE

See section 7.0 for test sequence.

Test Ref.	Item	Test Condition	Requirements
4.1.	Contact Resistance (IEC 512-2,test2a)	Mated connector with dry circuit of 20mV, 100mA maximum, per Appendix 1	Initial Value <50mΩ
4.2	Insulation Resistance (IEC 512-2,test 3a)	Unmated connector with 500 V DC between adjacent contacts	1000 MΩ minimum
4.3	Dielectric Strength (IEC 512-2,test 4a)	Unmated connector with 1000 V AC for 1 minute between adjacent contacts, as per Appendix 2	No voltage breakdown

REVISE ON PC ONLY:		TITLE:	PRODUCT SPECIFICATION FOR 2.54mm SIM Conn SMT	
J	SEE SHEET 1	THIS DOCUMENT CONTAINS INFORMATION THAT IS PROPRIETARY TO MOLEX INC. AND SHOULD NOT BE USED WITHOUT WRITTEN PERMISSION		
REV.	DESCRIPTION			
DOCUMENT NUMBER PS-99020-0071		FILENAME PS-99020	SHEET 3 of 15	
ES-40000-3996 REV. A SHEET 3 95/MAR/10 EC U5-0926 DCBRD03.LWP				



5.0 MECHANICAL PERFORMANCE

Test Ref.	Item	Test Condition	Requirements
5.1	Durability	Mate connector with SIM card inserted in holder at a rate of 10 cycles per minute to 5000 cycles. Use push button for card ejection, as per Appendix 3	Appearance - no damage. Maximum change from initial contact resistance = 20mΩ
5.2	Vibration (IEC 68-2-6)	10-150 Hz 0.15mm or 2g, duration 40 minutes, total 5 cycles in X,Y,Z axes	<1μsecond discontinuity. Maximum change from initial contact resistance = 20mΩ
5.3	Shock (IEC 68-2-27)	50g/11m sec ½ Sine, 3 shocks each of X,Y,Z axes, total 18 shocks	<1μsecond discontinuity. Maximum change from initial contact resistance = 20mΩ
5.4	Solder Tab Destruction Test	Apply a 4.9 N load for 1 min in all directions, as per Appendix 4	No damage to solder joints (cracks or damage)
5.5	Mating Force	Mate connectors at a rate of 25 ± 3 mm/min	Mating Force 4.9 N max
5.6	Unmating Force	Unmate connectors at a rate of 25 ± 3 mm/min	Unmating Force (push button force) 20N max
5.7	Card Holder Retention Force (latch enabled)	Pull card holder axially at 25-50 mm/min.	Retention Force 5N min
5.8	Terminal/Housing Retention Force	Apply an axial load to a terminal assembled in the housing at a speed of 25-50mm/min., as per Appendix 5	Retention Force 2.9 N min
5.9	Multi-axis Function Test for PCB Mounted Housing.	Apply Forces in all 4 directions, as per Appendix 6	F1/F2/F3/F4/F5>40N
5.10	Normal Force	Measure Normal Force per Appendix 8	Normal Force 0.2≤Fn≤0.7N.
5.11	Button Push Force	Measure Force per Appendix 9	Appearance – No visual or mechanical damage.

REVISE ON PC ONLY:		TITLE:	PRODUCT SPECIFICATION FOR 2.54mm SIM Conn SMT	
J	SEE SHEET 1	THIS DOCUMENT CONTAINS INFORMATION THAT IS PROPRIETARY TO MOLEX INC. AND SHOULD NOT BE USED WITHOUT WRITTEN PERMISSION		
REV.	DESCRIPTION			
DOCUMENT NUMBER PS-99020-0071		FILENAME PS-99020	SHEET 4 of 15	



6.0 ENVIRONMENTAL PERFORMANCE

Test Ref.	Item	Test Condition	Requirements
6.1	Resistance to solder conditions	a) Sample to be passed twice through reflow oven according to temp profile shown in appendix 7. One hour cooling between passes. b) Manual soldering at solder temp. of 300 ±5°C for 3 sec.	Appearance - no damage
6.2	Solderability (IEC 68-2-20, test Ta, method 1)	Samples to be steam aged for 16 hrs using a steam aging chamber, or equivalent. Solder temp. 235±5°C, wetting time 3 sec.	95% of immersed area must show no voids, pin holes, etc.
6.3	Damp Heat Cyclic (IEC 68-2-30, variant 1)	Upper air temp. 25-55°C for 6 cycles, duration 6 days Recovery is 2 hrs at std. atmospheric condition.	Appearance - no damage. Maximum change from initial contact resistance = 20mΩ
6.4	Salt Spray (IEC 512-6, test 11f)	5+/-1% salt solution Duration 48 hrs	Appearance - no damage. Maximum change from initial contact resistance = 20mΩ
6.5	Long Term Dry Heat	105°C for 1000 hours	Appearance - no damage. Maximum change from initial contact resistance = 20mΩ
6.6	Temperature Change (IEC 68-2-14)	Ta = -30°C, Tb =85°C, rate of change of temperature 1±0.2 C/minute 8 hours/cycle for 5 cycles Recovery is 2 hrs at std. atmospheric condition.	Appearance - no damage. Maximum change from initial contact resistance = 20mΩ
6.7	Thermal Shock (IEC 68-2-14)	-40°C to +85°C 5 cycles per hour (total 5 hours)	Appearance - no damage. Maximum change from initial contact resistance = 20mΩ

REVISE ON PC ONLY:		TITLE:	PRODUCT SPECIFICATION FOR 2.54mm SIM Conn SMT	
J	SEE SHEET 1			
THIS DOCUMENT CONTAINS INFORMATION THAT IS PROPRIETARY TO MOLEX INC. AND SHOULD NOT BE USED WITHOUT WRITTEN PERMISSION				
REV.	DESCRIPTION			
DOCUMENT NUMBER PS-99020-0071		FILENAME PS-99020	SHEET 5 of 15	



Product Specification



LANGUAGE

English

6.8	SO ₂ (IEC 68-2-42-KC)	Mated connectors exposed to 10 ±3ppm of SO ₂ gas with 85-90% humidity at 40 ±2°C for 96 hours.	Appearance - no damage. Maximum change from initial contact resistance = 20mΩ
6.9	Temperature Rise Test	Mate connector and measure the temperature rise of the contacts when the max. rated DC current is applied	Temperature rise of 30 °C max
6.10	Cold Resistance	Mate connectors and expose to -40 ±3°C for 96 hours. Allow samples to reach room temp (1hr) before measurement.	Appearance - no damage. Maximum change from initial contact resistance = 20mΩ
6.11	Heat Resistance	Mate connectors and expose to 85 ±2°C for 96 hours. Allow samples to reach room temp (1hr) before measurement.	Appearance - no damage. Maximum change from initial contact resistance = 20mΩ

REVISE ON PC ONLY:		TITLE:	PRODUCT SPECIFICATION FOR 2.54mm SIM Conn SMT	
J	SEE SHEET 1	THIS DOCUMENT CONTAINS INFORMATION THAT IS PROPRIETARY TO MOLEX INC. AND SHOULD NOT BE USED WITHOUT WRITTEN PERMISSION		
REV.	DESCRIPTION			
DOCUMENT NUMBER PS-99020-0071		FILENAME PS-99020	SHEET 6 of 15	
ES-40000-3996 REV. A SHEET 3 95/MAR/10 EC U5-0926 DCBRD03.LWP				



7.0 TEST GROUPINGS

Test Ref.	Test Item	GP1	GP2	GP3	GP4	GP5
4.1	Contact Resistance	2,4,6	2,8,12	2,4,6,8	2,4,7,9	
4.2	Insulation Resistance		5,13			
4.3	Dielectric Strength		6,14			
5.1	Durability		7			
5.2	Vibration				5	
5.3	Shock				6	
5.4	Solder Tab Destruction Test.					2
5.5	Mating Force.		3,10			2
5.6	Unmating Force.		4,9			
5.7	Card Retention Force.					2
5.8	Terminal/Housing Retention Force					2
5.9	Multi-action Function Test for PCB Mounted Housing					2
5.10	Normal Force at maximum deflection	3,7				
5.11	Button Push Force					1
6.1	Resistance to Solder Conditions	1	1	1	1	1
6.2	Solderability					2
6.3	Damp Heat Cyclic		11			
6.4	Salt Spray			5		
6.5	Long Term Dry Heat	5				
6.6	Temp. Change				3	
6.7	Thermal Shock			3		
6.8	SO ₂				8	
6.9	Temperature Rise					2
6.10	Cold Resistance			7		
6.11	Heat Resistance					2

REVISE ON PC ONLY:		TITLE:	PRODUCT SPECIFICATION FOR 2.54mm SIM Conn SMT	
J	SEE SHEET 1	THIS DOCUMENT CONTAINS INFORMATION THAT IS PROPRIETARY TO MOLEX INC. AND SHOULD NOT BE USED WITHOUT WRITTEN PERMISSION		
REV.	DESCRIPTION			
DOCUMENT NUMBER PS-99020-0071		FILENAME PS-99020	SHEET 7 of 15	



Appendix 1:

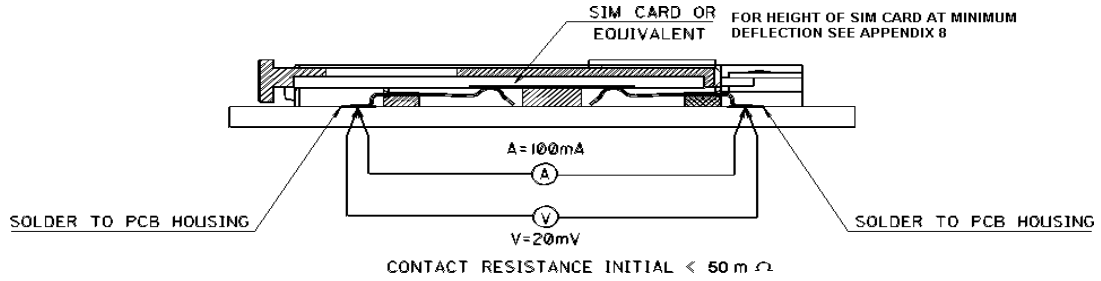

Contact Resistance Across Cardholder Bridge Contact (4.1)

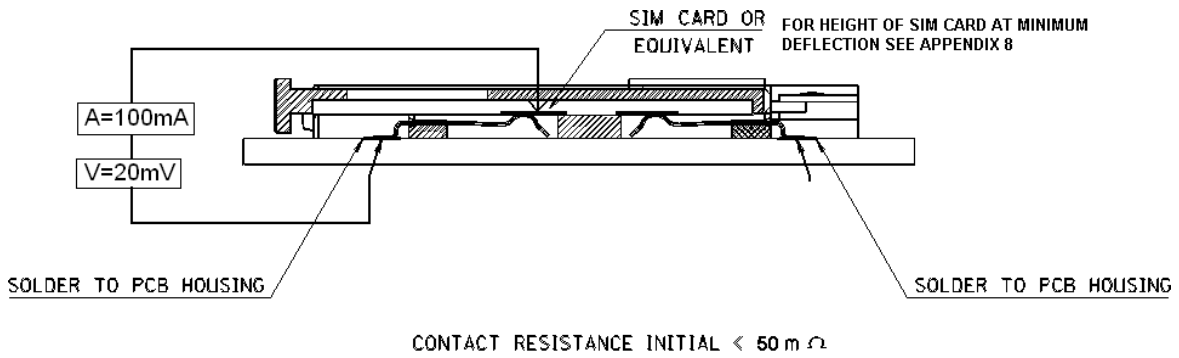

Contact Resistance Across Sim Card and Signal Contacts (4.1)

REVISE ON PC ONLY:		TITLE:	PRODUCT SPECIFICATION FOR 2.54mm SIM Conn SMT	
J	SEE SHEET 1			
THIS DOCUMENT CONTAINS INFORMATION THAT IS PROPRIETARY TO MOLEX INC. AND SHOULD NOT BE USED WITHOUT WRITTEN PERMISSION				
REV.	DESCRIPTION		FILENAME	SHEET
	DOCUMENT NUMBER PS-99020-0071		PS-99020	8 of 15
ES-40000-3996 REV. A SHEET 3 95/MAR/10 EC U5-0926 DCBRD03.LWP				



Appendix 2:

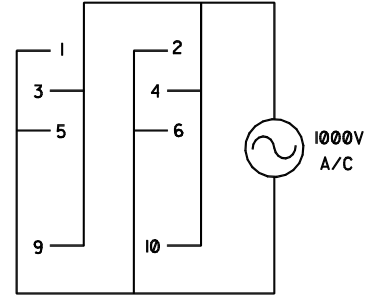
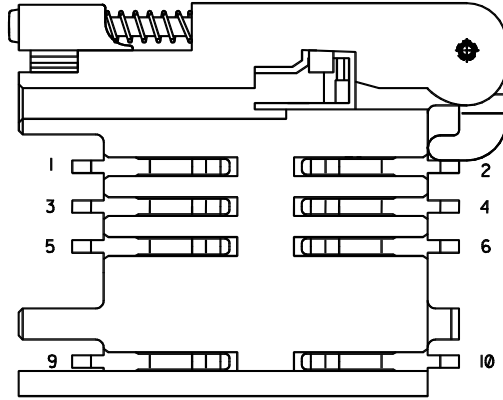

DIELECTRIC STRENGTH WIRING DIAGRAM

Dielectric Strength (4.3)

REVISE ON PC ONLY:		TITLE:	PRODUCT SPECIFICATION FOR 2.54mm SIM Conn SMT	
J	SEE SHEET 1			
THIS DOCUMENT CONTAINS INFORMATION THAT IS PROPRIETARY TO MOLEX INC. AND SHOULD NOT BE USED WITHOUT WRITTEN PERMISSION				
REV.	DESCRIPTION			
DOCUMENT NUMBER PS-99020-0071		FILENAME PS-99020	SHEET 9 of 15	



Appendix 3:

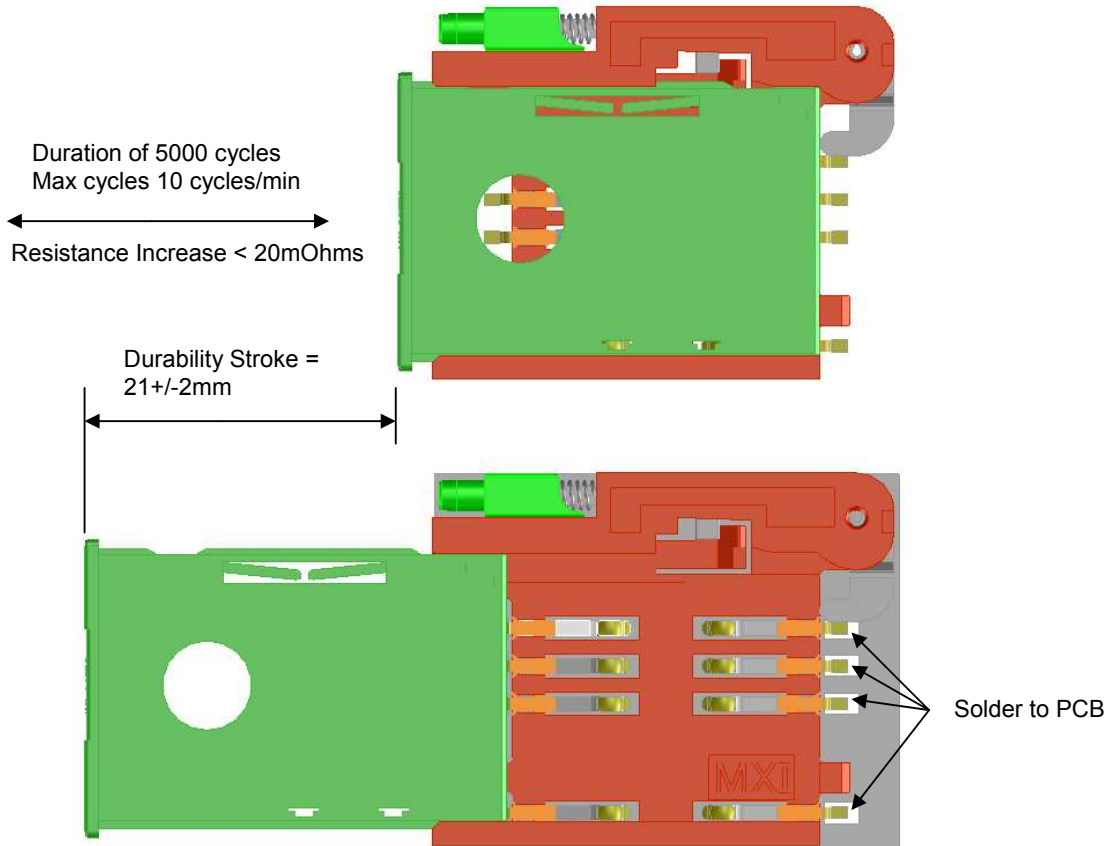

Durability (5.1)

REVISE ON PC ONLY:		TITLE:	PRODUCT SPECIFICATION FOR 2.54mm SIM Conn SMT	
J	SEE SHEET 1	THIS DOCUMENT CONTAINS INFORMATION THAT IS PROPRIETARY TO MOLEX INC. AND SHOULD NOT BE USED WITHOUT WRITTEN PERMISSION		
REV.	DESCRIPTION			
DOCUMENT NUMBER PS-99020-0071		FILENAME PS-99020	SHEET 10 of 15	
ES-40000-3996 REV. A SHEET 3 95/MAR/10 EC U5-0926 DCBRD03.LWP				



Appendix 4:

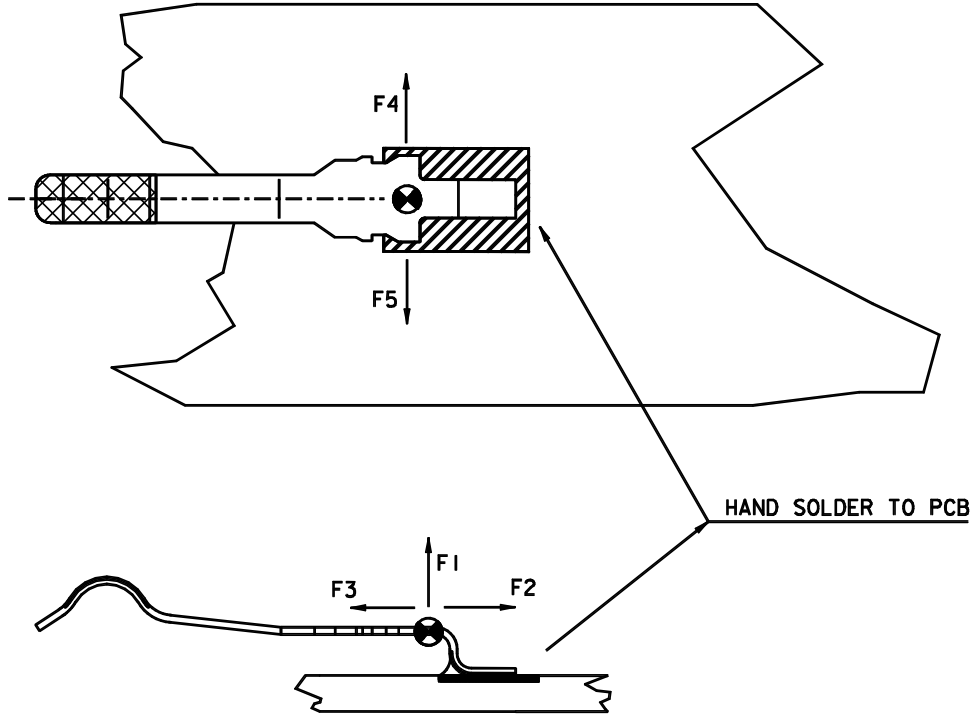

Solder Tab Destruct Test (5.4)

Appendix 5:

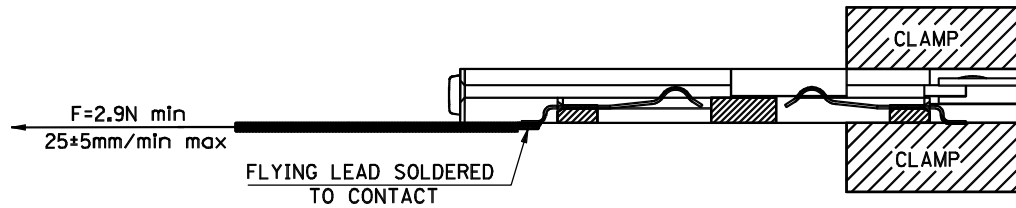

Terminal/Housing Retention Force (5.8)

REVISE ON PC ONLY:		TITLE:	PRODUCT SPECIFICATION FOR 2.54mm SIM Conn SMT	
J	SEE SHEET 1	THIS DOCUMENT CONTAINS INFORMATION THAT IS PROPRIETARY TO MOLEX INC. AND SHOULD NOT BE USED WITHOUT WRITTEN PERMISSION		
REV.	DESCRIPTION			
DOCUMENT NUMBER PS-99020-0071		FILENAME PS-99020	SHEET 11 of 15	
ES-40000-3996 REV. A SHEET 3 95/MAR/10 EC U5-0926 DCBRD03.LWP				



Appendix 6:

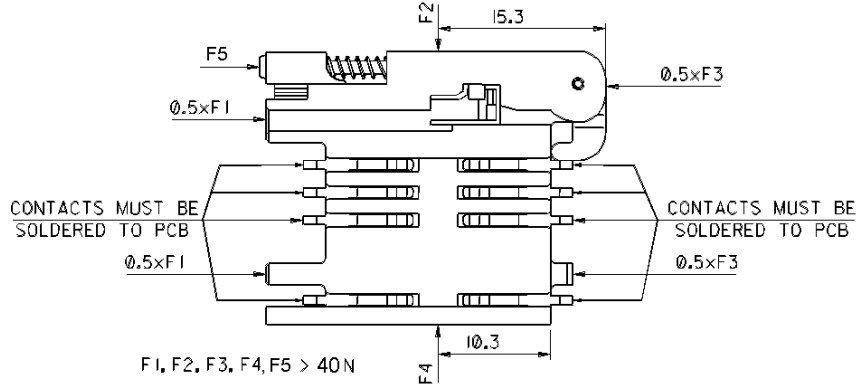

Multitaxis Function Test (5.9)

REVISE ON PC ONLY:		TITLE:	PRODUCT SPECIFICATION FOR 2.54mm SIM Conn SMT	
J	SEE SHEET 1			
THIS DOCUMENT CONTAINS INFORMATION THAT IS PROPRIETARY TO MOLEX INC. AND SHOULD NOT BE USED WITHOUT WRITTEN PERMISSION				
REV.	DESCRIPTION			
DOCUMENT NUMBER PS-99020-0071		FILENAME PS-99020	SHEET 12 of 15	
ES-40000-3996 REV. A SHEET 3 95/MAR/10 EC U5-0926 DCBRD03.LWP				



Appendix 7:

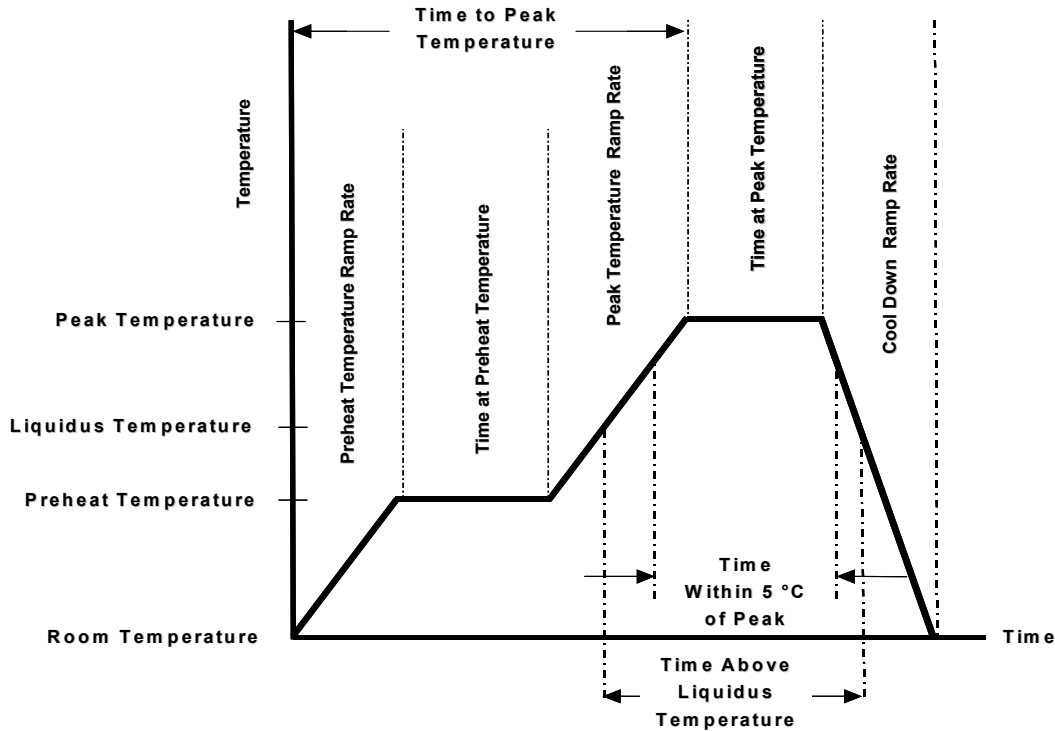

REFLOW SOLDERING SIMULATION PEAK PROFILE REFLOW AT 260 °C

DESCRIPTION	REQUIREMENT
Solder Type	None
Solder Flux Type	None
Paste Flux Type	None
Average Ramp Rate	3 °C/second maximum
Preheat Temperature	150 °C minimum; 200 °C maximum
Preheat Time	60 to 180 seconds
Ramp to Peak	3 °C/second maximum
Time over Liquidus (217 °C)	60 to 150 seconds
Peak Temperature	260 °C +0/-5 °C
Time within 5 °C of peak	20 to 40 seconds
Ramp – Cool Down	6 °C/second maximum
Time 25 °C to Peak	8 minutes maximum

Resistance to Solder Conditions (6.1)

REVISE ON PC ONLY:		TITLE:	PRODUCT SPECIFICATION FOR 2.54mm SIM Conn SMT	
J	SEE SHEET 1			
THIS DOCUMENT CONTAINS INFORMATION THAT IS PROPRIETARY TO MOLEX INC. AND SHOULD NOT BE USED WITHOUT WRITTEN PERMISSION				
REV.	DESCRIPTION		FILENAME	SHEET
	DOCUMENT NUMBER PS-99020-0071		PS-99020	13 of 15



Appendix 8:

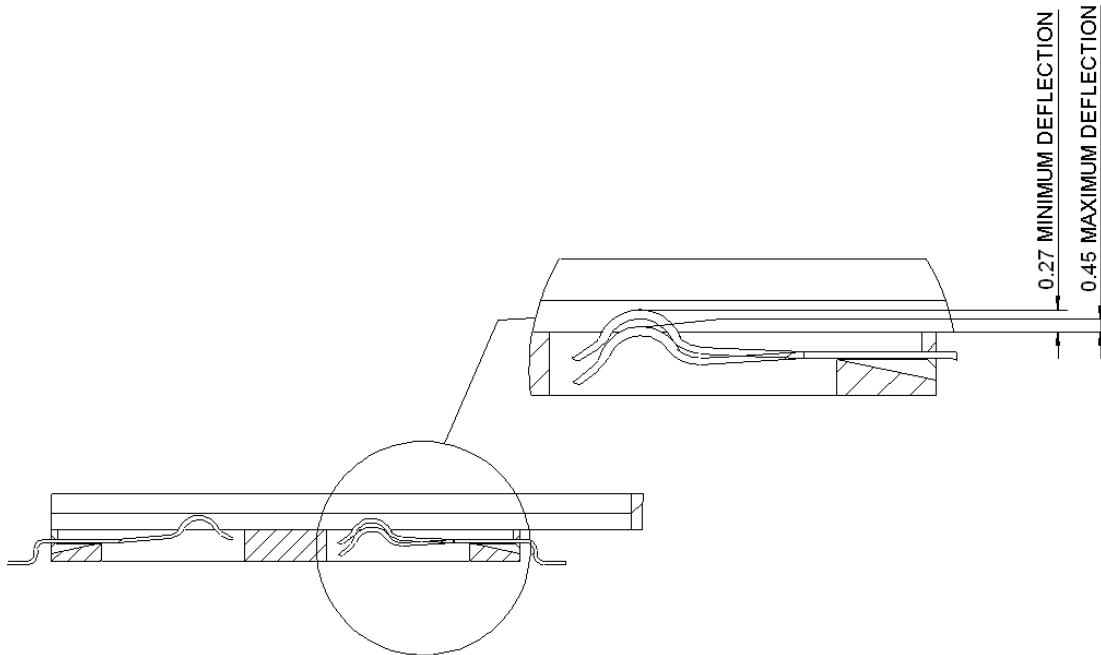

Maximum Normal Force (5.10)

REVISE ON PC ONLY:		TITLE:	PRODUCT SPECIFICATION FOR 2.54mm SIM Conn SMT	
J	SEE SHEET 1	THIS DOCUMENT CONTAINS INFORMATION THAT IS PROPRIETARY TO MOLEX INC. AND SHOULD NOT BE USED WITHOUT WRITTEN PERMISSION		
REV.	DESCRIPTION			
DOCUMENT NUMBER PS-99020-0071		FILENAME PS-99020	SHEET 14 of 15	
ES-40000-3996 REV. A SHEET 3 95/MAR/10 EC U5-0926 DCBRD03.LWP				



Appendix 9:

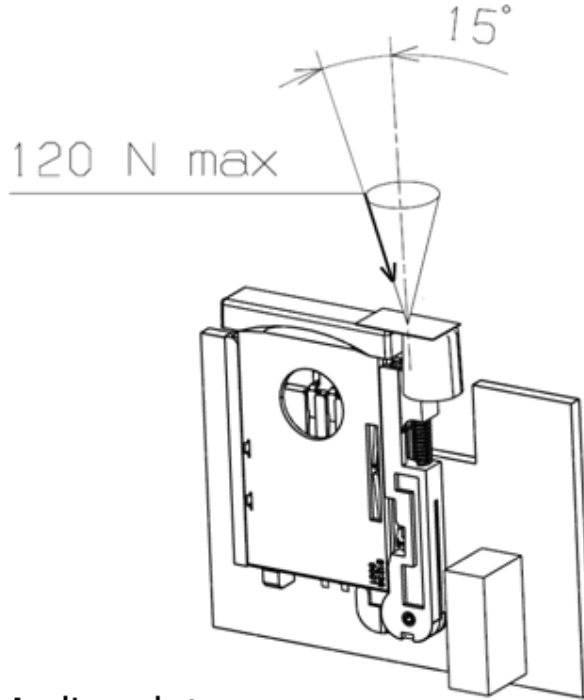

Applies only to:
 91980-0010
 92201-0047
 92201-0048

Button Push Force (5.11)

Force of 120N min must be applied as described with an angle of 15° max.
 Under 120N Sim reader must function at full performance and respect dimension
 4.8mm MAX.

REVISE ON PC ONLY:		TITLE:	PRODUCT SPECIFICATION FOR 2.54mm SIM Conn SMT	
J	SEE SHEET 1	THIS DOCUMENT CONTAINS INFORMATION THAT IS PROPRIETARY TO MOLEX INC. AND SHOULD NOT BE USED WITHOUT WRITTEN PERMISSION		
REV.	DESCRIPTION			
DOCUMENT NUMBER PS-99020-0071		FILENAME PS-99020	SHEET 15 of 15	