

Straight SMA Low Loss Diameter .195, .200 and .240 Straight Type Plugs

1. Identify connector parts. (3 piece parts – except bulkhead)
2. Strip cable to dimensions shown. Do not nick braid, foil or center conductor. Cut foil flush with dielectric, do not remove foil. Make sure that dielectric is clean and free from all particles. Tin center conductor, keeping solder amount to a minimum. Slide crimp sleeve onto jacket of cable.
3. Assemble contact onto cable as shown. Position contact such that a gap of no more than .020 (0.51) is kept between dielectric and contact. Solder contact to center conductor through solder hole using .020 (0.51) Diameter solder. Use a minimum amount of solder for a good joint. Do not allow contact to move into dielectric during soldering process.
4. Flare braid and slide body assembly over contact, foil and dielectric, then under braid. Seat body assembly firmly onto contact. Arrange braid uniformly around crimp stem. Slide crimp sleeve forward and crimp using Johnson hand crimp tool 141-0000-913 and recommended crimp die hex.

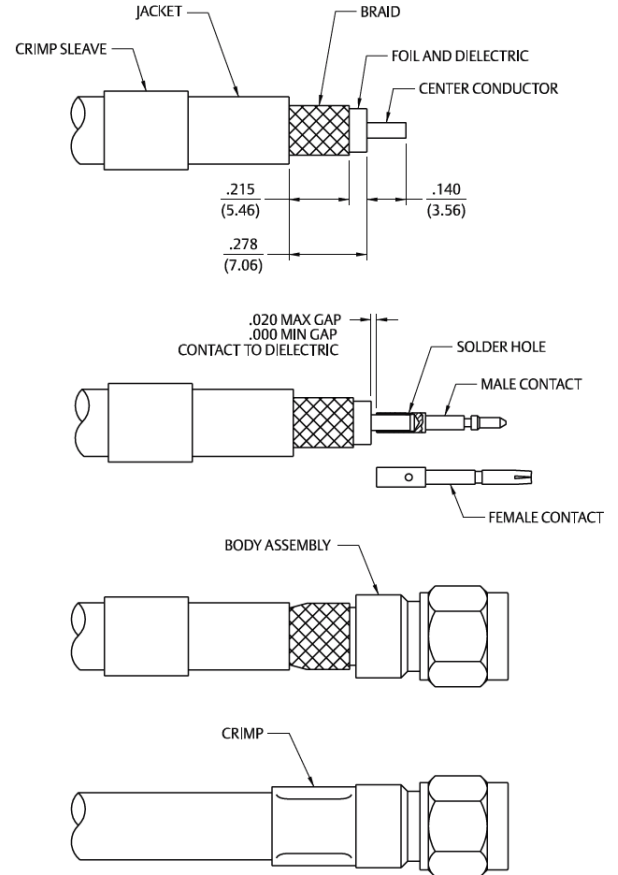

Cable Group	Part No.	Crimp Hex
LMR-195	142-0307-411	.213 (5.41).213 (5.41)
	142-0307-416	
LMR-240	142-0335-401	.255 (6.48).255 (6.48)
	142-0335-406	
LMR-200	142-0339-401	.213 (5.41).213 (5.41)
	142-0339-406	
LMR-195	142-0407-011	.213 (5.41).213 (5.41)
	142-0407-016	
LMR-240	142-0435-001	.255 (6.48).255 (6.48)
	142-0435-006	
LMR-200	142-0439-001	.213 (5.41).213 (5.41)
	142-0439-006	
LMR-240	142-4435-001	.255 (6.48).255 (6.48)
	142-4435-006	
LMR-200	142-4439-001	.213 (5.41).213 (5.41)
	142-4439-006	
LMR-195	142-4407-001	.213 (5.41).213 (5.41)
	142-4407-006	
LMR-240	142-5435-001	.255 (6.48).255 (6.48)
	142-5435-006	
LMR-200	142-5439-001	.213 (5.41).213 (5.41)
	142-5439-006	
LMR-195	142-5407-001	.213 (5.41).213 (5.41)
	142-5407-006	

