

LOC	DIST	P	F	ZONE	LTR	DESCRIPTION	DATE	APPD	
DF	XO				L	REV PER 0H14-0170-04	CT	3-9-04	SG

### ASSEMBLED VIEW

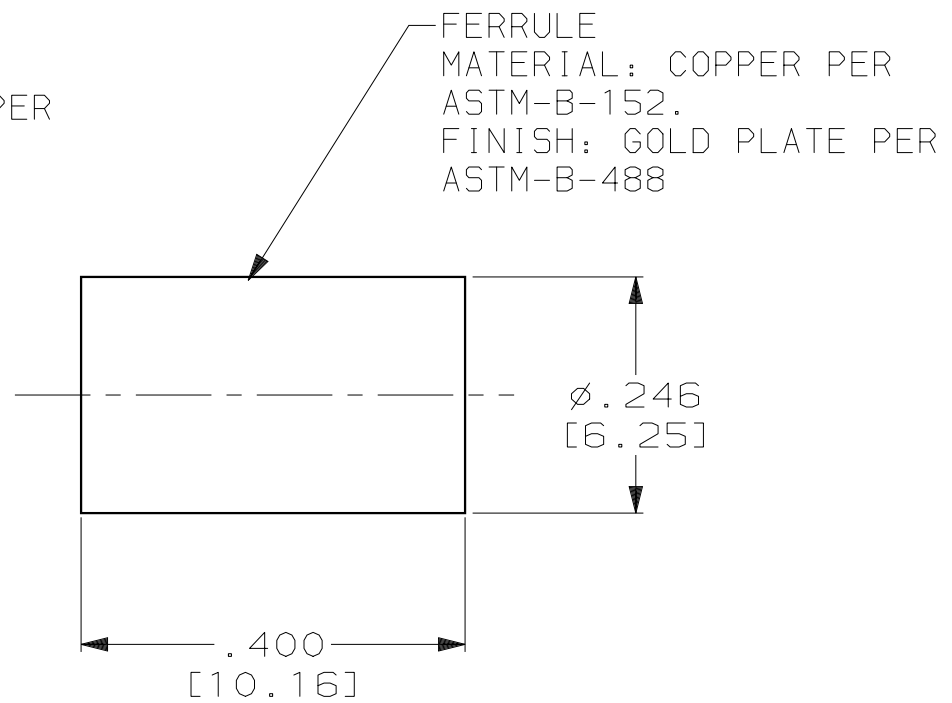
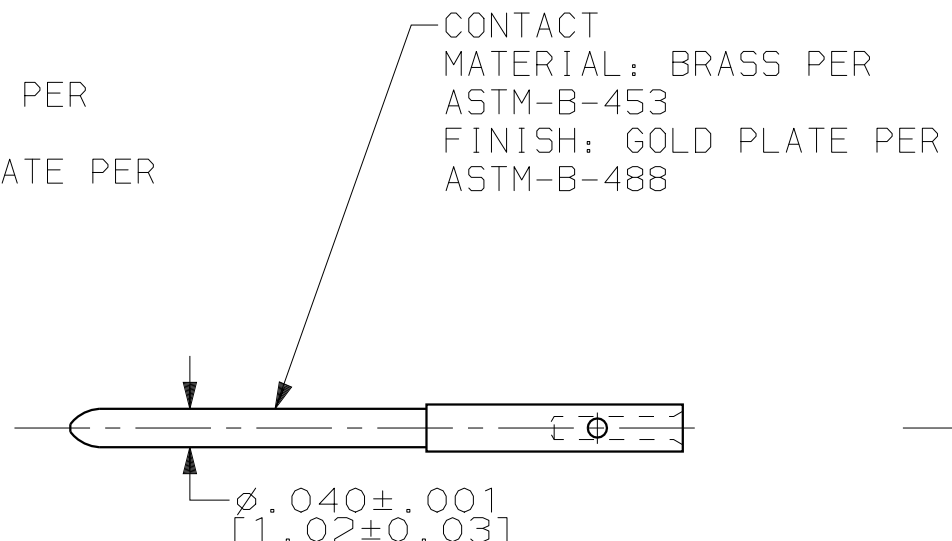
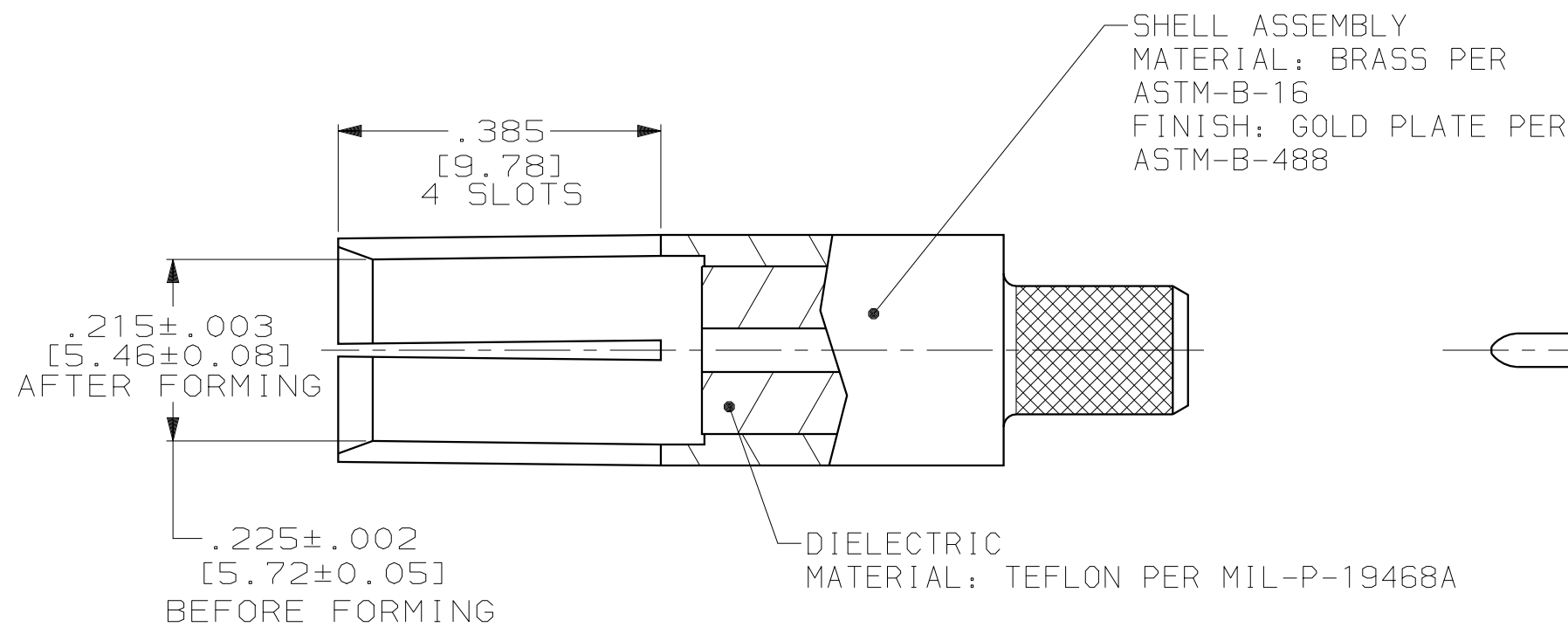
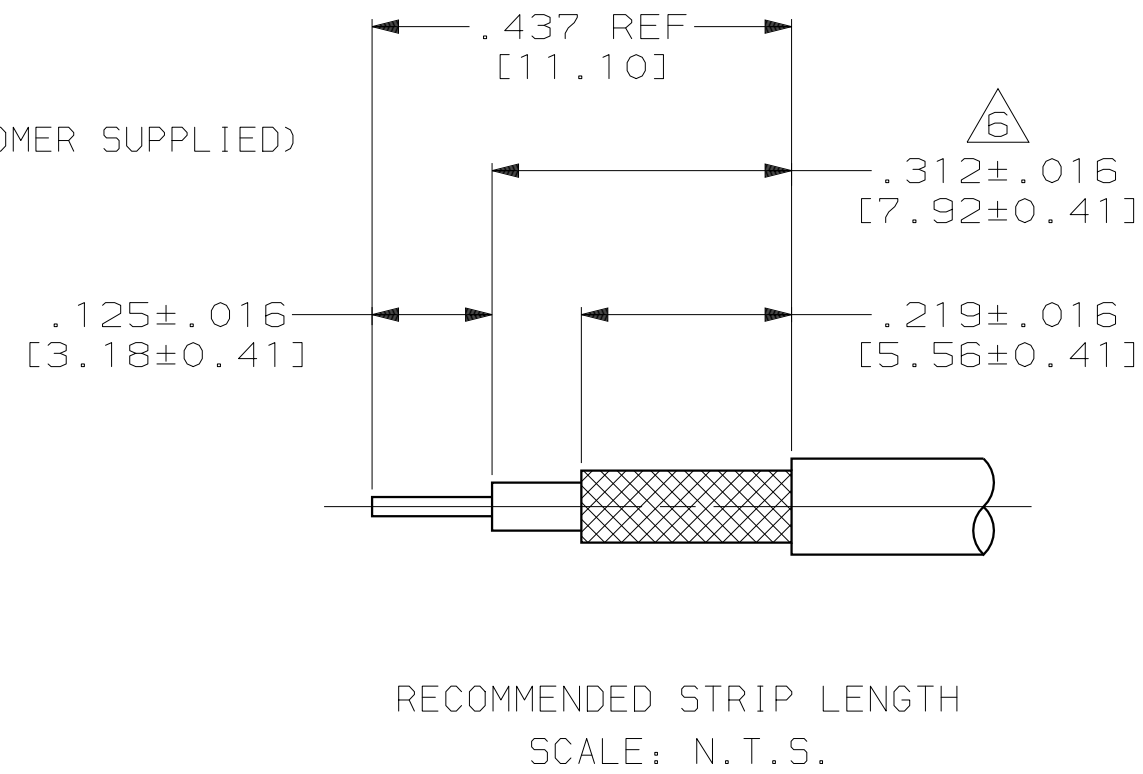
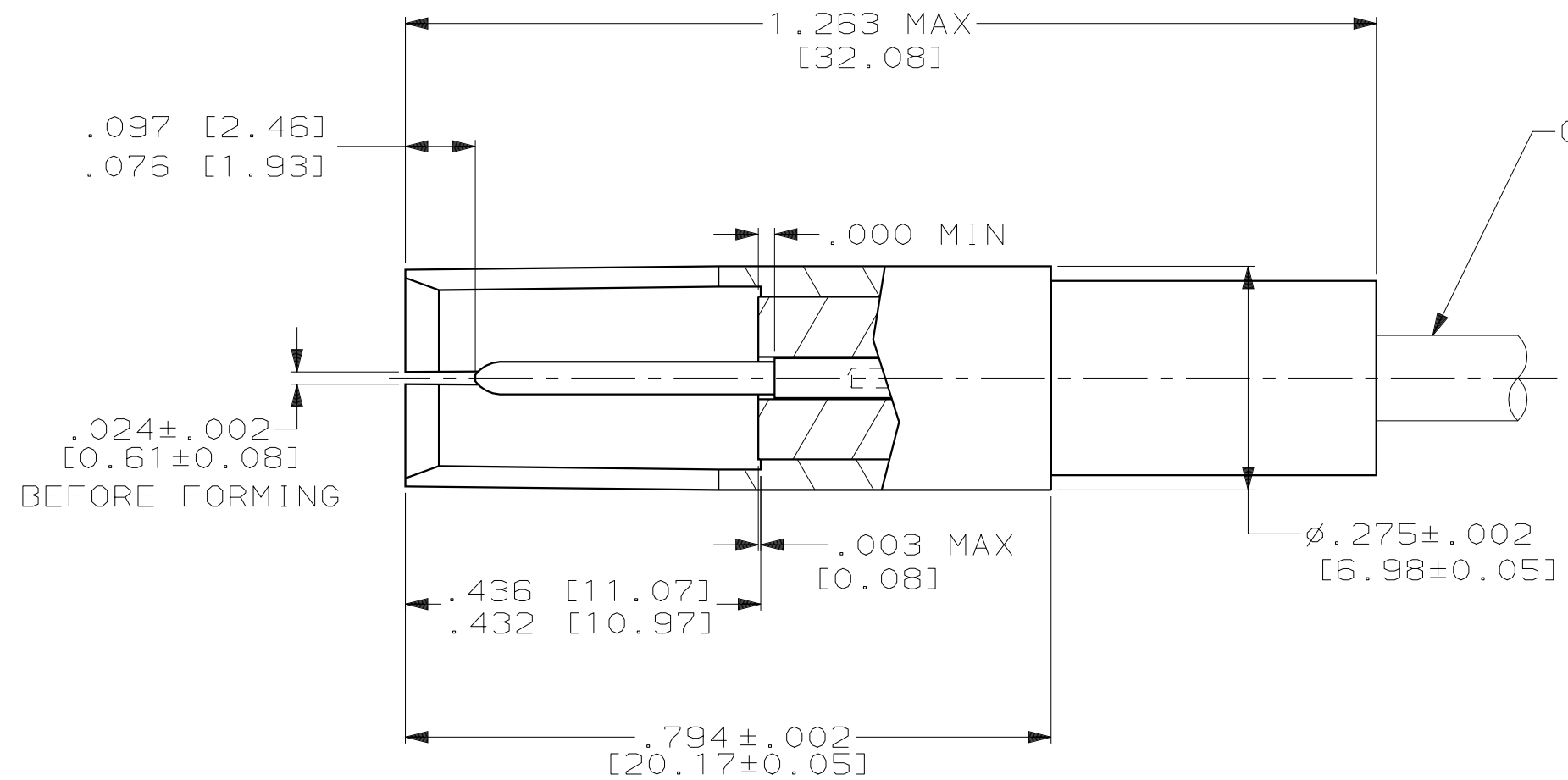

- FOR USE WITH RG-223/U, 142A/U & 142B/U COAX CABLE.
- FERRULE CRIMPING TOOL: AMP TOOL #220066-1 OR 220066-2 CRIMP B.
- CONTACT CRIMPING TOOL: M22520/2-01 OR AMP TOOL NUMBER 1-601966-6, SETTING NUMBER 5. DANIELS POSITIONER PART NO. K345 OR AMP TOOL NO. 1-601966-6.
- SEE I.S.2348.
- DANIELS MANUFACTURING CORP  
 2266 FRANKLIN ROAD  
 BLOOMFIELD HILLS, MI 48013
- OUTER JACKET OF CABLE MUST BE TRIMMED TO ALLOW PROPER INTER-PIN CONTACT LOCATION AFTER FERRULE CRIMP OPERATION.
- PARTS SHIPPED UNASSEMBLED AND CABLE IS SUPPLIED BY CUSTOMER.

THIS DRAWING IS A CONTROLLED DOCUMENT FOR AMP INCORPORATED. IT IS SUBJECT TO CHANGE AND THE CONTROLLING ENGINEERING ORGANIZATION SHOULD BE CONTACTED FOR THE LATEST REVISION.

DO NOT SCALE PRINT. UNLESS SPECIFIED DIMENSIONS IN INCHES [mm] TOLERANCES ON : 2 PLC DEC ± - 3 PLC DEC ± .005 [0.13] ANGLES ± -	DR 9-12-94 C.C.THOMAS	AMP Incorporated Harrisburg, PA 17105-3608	
	CHK 9-23-94 J.CABARLO		
MATERIAL SEE CALLOUTS	APPD 9-23-94 J.CABARLO	SIZE C 00779	DRAWING NO C=225791-2
FINISH SEE CALLOUTS	RLSE 9-23-94 C.C.THOMAS	SCALE 5:1	SHEET 1 OF 1
	PRODUCT SPEC -		
	APPLICATION SPEC -		
	WEIGHT -		

225791-2  
PART NO.