

Apr.1.2017 Copyright 2017 HIROSE ELECTRIC CO., LTD. All Rights Reserved.

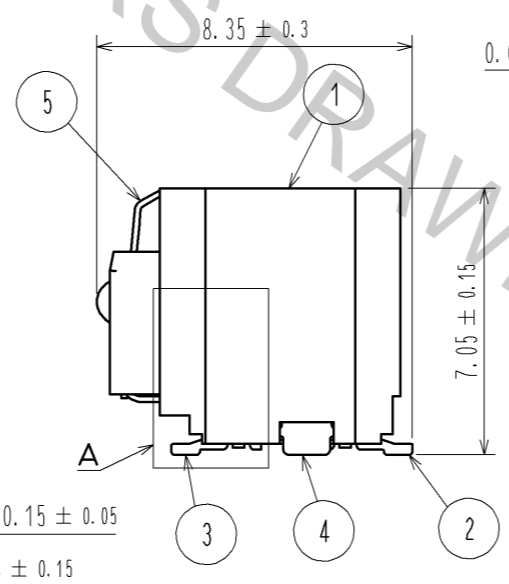

MATING FIGURE (5:1)

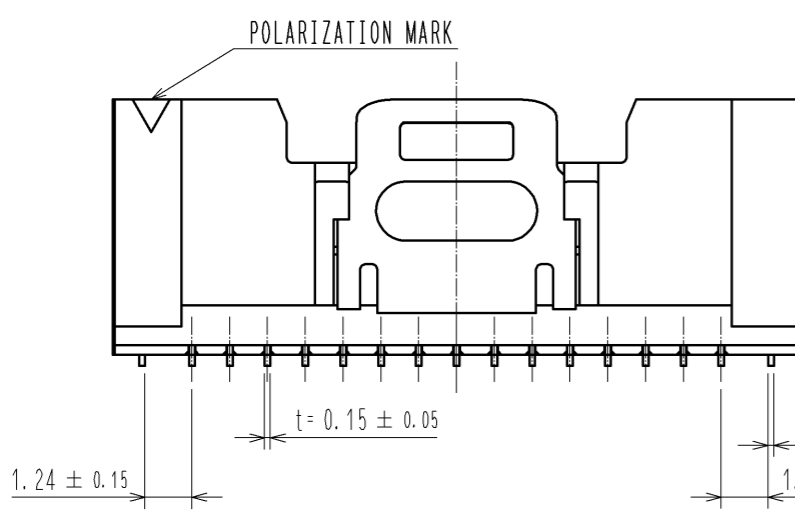
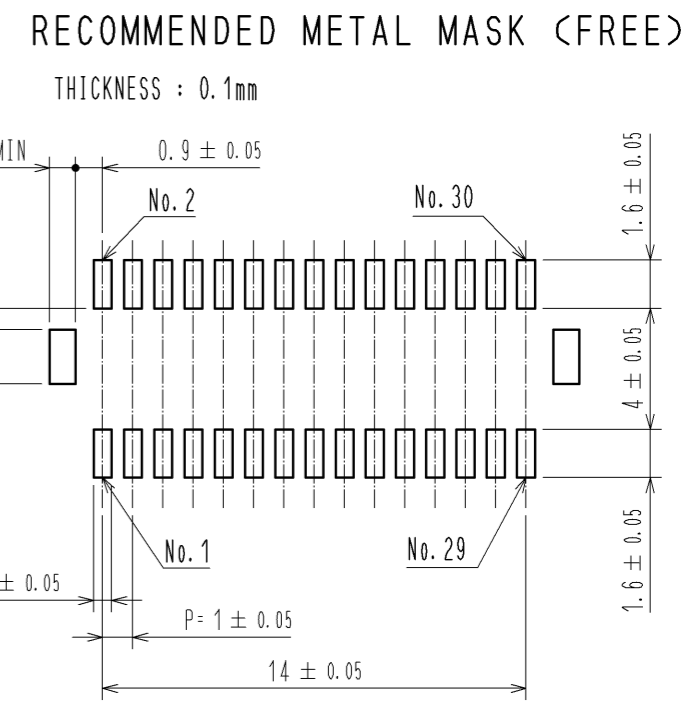
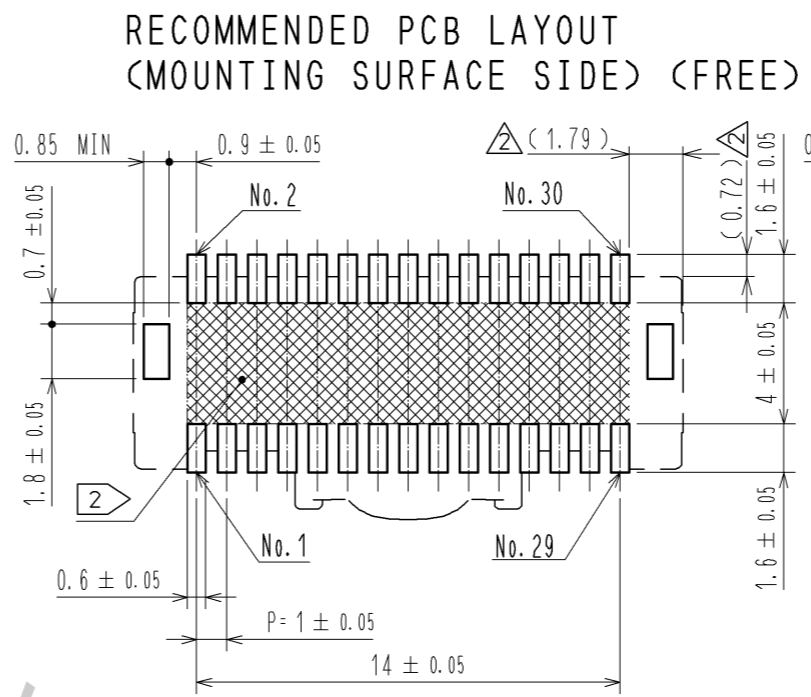
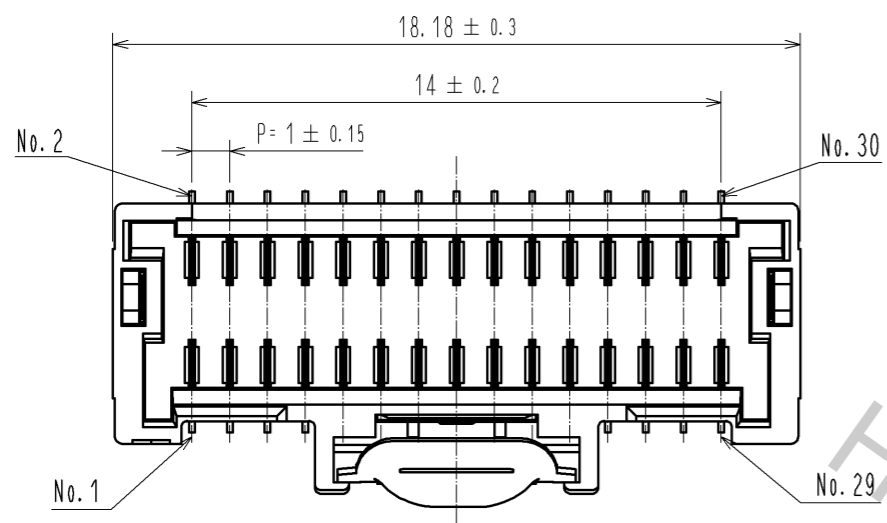
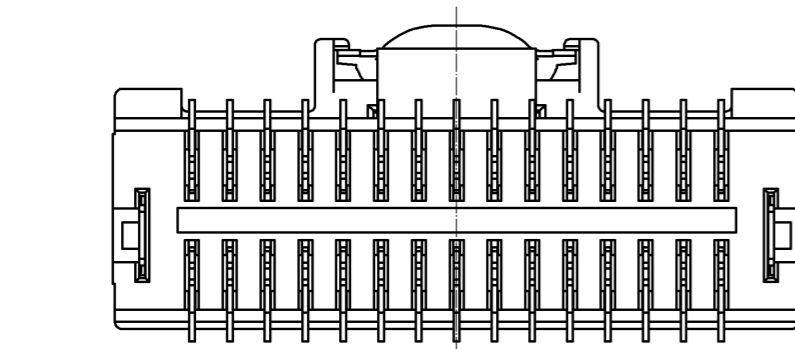
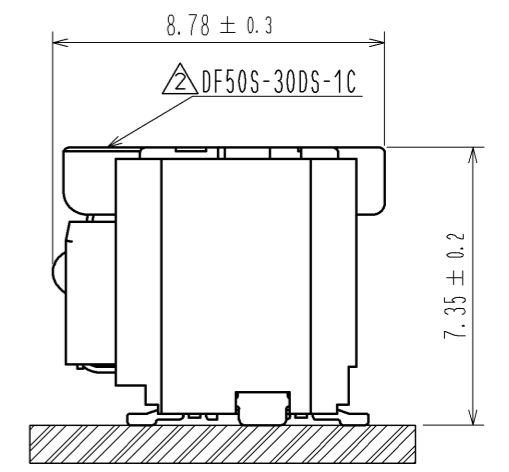
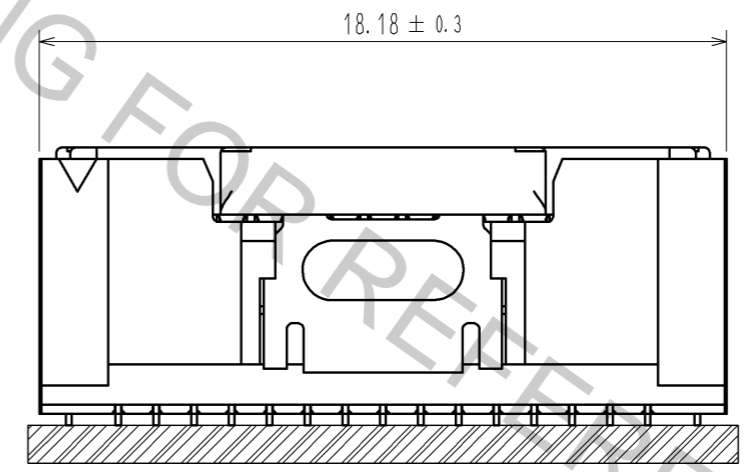

A (10:1)

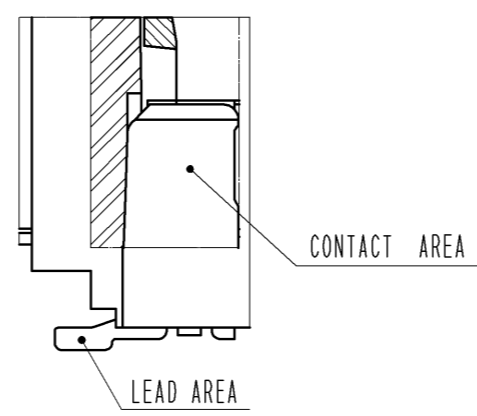

- NOTES 1. LEAD CO-PLANARITY SHALL BE 0.1mm MAX  
 2. [Cross-hatched area symbol] AREA INDICATED MUST BE FREE OF CONDUCTIVE TRACES OR THE CONDUCTIVE TRACES MUST BE COVERED BY RESIST FILM.  
 3. PLEASE CONSULT HIROSE WHEN THE PRODUCT IS MONUTED TO FPC.

3	BRASS	CONTACT AREA : Au PLATING 0.05μm MIN LEAD AREA : Au PLATING 0.05μm MIN UNDER PLATING : Ni PLATING 1μm MIN	8	PS	REEL , BLACK
2	BRASS	CONTACT AREA : Au PLATING 0.05μm MIN LEAD AREA : Au PLATING 0.05μm MIN UNDER PLATING : Ni PLATING 1μm MIN	7	POLYESTER	CLEAR
1	LCP	BLACK , UL94V-0	6	PS	CLEAR
			5	STAINLESS STEEL	—
			4	BRASS	CONTACT AREA : Sn PLATING 1μm MIN UNDER PLATING : Ni PLATING 0.5μm MIN
NO.	MATERIAL	FINISH , REMARKS	NO.	MATERIAL	FINISH , REMARKS
UNITS : mm		SCALE : FREE	COUNT : 5	DESCRIPTION OF REVISIONS : DIS-H-007735	
DESIGNED : MI. SAKIMURA		CHECKED : TS. KUMAZAWA		DATE : 13.03.22	
APPROVED : TS. SAKATA		09.12.04		DRAWING NO. : EDC3-320002-01	
CHECED : MN. KENJO		09.12.04		PART NO. : DF50-30DP-1V(51)	
DESIGNED : TT. OHSAKO		09.12.04		CODE NO. : CL665-0001-8-51	
DRAWN : TT. OHSAKO		09.12.04		1/2	

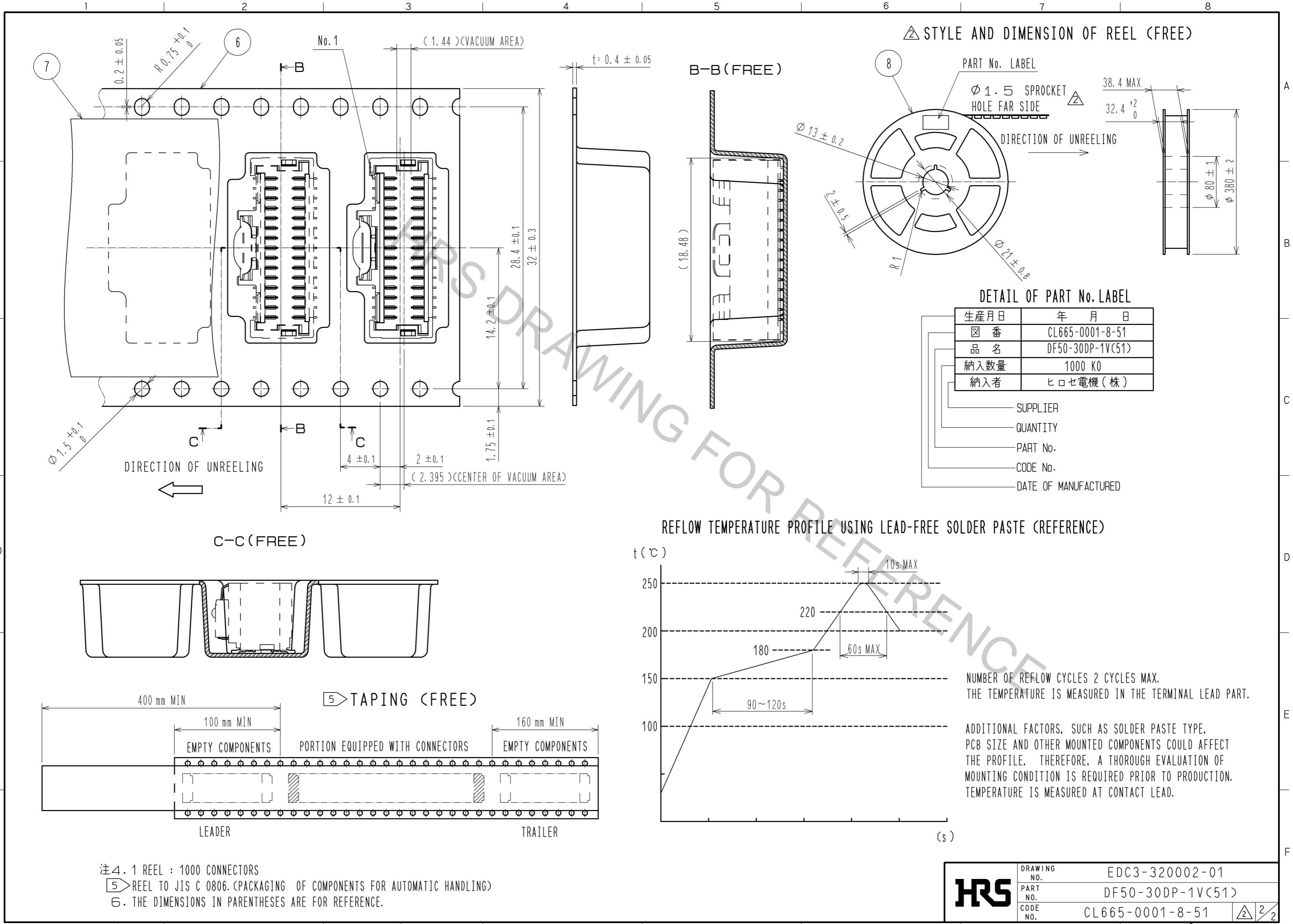

注4.1 REEL : 1000 CONNECTORS  
 ⑤ REEL TO JIS C 0806. (PACKAGING OF COMPONENTS FOR AUTOMATIC HANDLING)  
 ⑥ THE DIMENSIONS IN PARENTHESES ARE FOR REFERENCE.

<b>HRS</b>	DRAWING NO.	EDC3-320002-01	2/2
	PART NO.	DF50-30DP-1V(51)	
	CODE NO.	CL665-0001-8-51	