

PART No.	CODE No.	NUMBER OF CONTACTS	G	H	J	K	L
DF9A-9S-1V(69)	-	9	24	-	11.5	8.7	25.5
DF9A-11S-1V(69)	-	11	24	-	11.5	9.7	25.5
DF9A-13S-1V(69)	CL540-0006-7-69	13	24	-	11.5	10.7	25.5
DF9A-15S-1V(69)	CL540-0007-0-69	15	24	-	11.5	11.7	25.5
DF9A-17S-1V(69)	-	17	24	-	11.5	12.7	25.5
DF9A-19S-1V(69)	-	19	24	-	11.5	13.7	25.5
DF9A-21S-1V(69)	CL540-0010-4-69	21	24	-	11.5	14.7	25.5
DF9A-23S-1V(69)	-	23	32	28.4	14.2	15.7	33.5
DF9A-25S-1V(69)	CL540-0012-0-69	25	32	28.4	14.2	16.7	33.5
DF9A-31S-1V(69)	CL540-0013-2-69	31	32	28.4	14.2	19.7	33.5
DF9A-41S-1V(69)	CL540-0222-2-69	41	44	40.4	20.2	24.7	45.5
DF9A-51S-1V(69)	CL540-0014-5-69	51	44	40.4	20.2	29.7	45.5

- NOTES
- 4 : 1 REEL 1000 CONNECTORS.
 - 5 : AT THE BEIGINNING OF THE REEL, 30 COMPONENTS SHALL BE EMPTY. AT THE END OF THE REEL, 20 COMPONENTS SHALL BE EMPTY.
 - 6 : LET THE SENDING HOLE OF 9 TO 21 CONTACTS BE ONLY THE UPPER ONE SIDE TOWARD A DRAWING. THE SENDING HOLE OF 23 OR MORE CONTACTS IS ESTABLISHED IN BOTH SIDES, AS SHOWN IN A FIGURE.
 - 7 : A POCKET SHAPE IS DIFFERET AT INTERVALS OF EACH CAVITY NUMBER TO AVOID OVERLAP.
 - 8 : PEEL FORCE REFERS TO JIS C 0806.
 - 9 : AFTER PACKING, ROLL 2 METERS OF THE REINFORCEMENT COLLAR TO OUTER CIRCUMFERENCE OF TAPE AND REEL POCKET, AND TAPE DOWN AT THE END THE COLLAR.

DETAIL OF PART NO. LABEL

- SUPPLIER
- QUANTITY
- PART NO.
- CODE NO.
- DATE OF MANUFACTURED

生産月日	年 月 日
☒番	CL540-****-**-69
品名	DF9A-*S-1V(69)
納入数量	1000K口
納入者	ヒロセ電機(株)

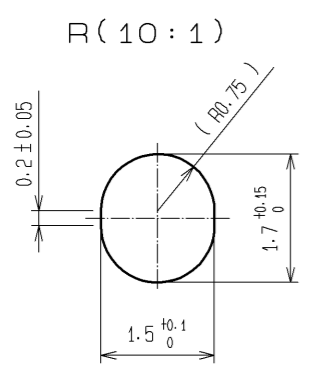

HRS	DRAWING NO.	EDC3-162417-03
	PART NO.	DF9A-*S-1V(69)
	CODE NO.	CL540-