

ATLANTIC VERSION TERMINATOR INTERFACE ADAPTER	PART NUMBER	REVISION	DESCRIPTION	FEED TYPE	APPLICATOR STYLE CONVERSION CHART						
					CONVERT TO	PART NUMBERS REQUIRED					
	2151311-1	D	FINE CRIMP HEIGHT ADJUST	MECHANICAL	PNEUMATIC FEED	2119950-1	1338685-1	5-18022-5	2119641-1	2119799-1	2063440-1
					SERVO LATCH PLATE	2119951-1	-	8-2151311-5	1901094-3	-	2168400-6 (QUANTITY 2)
					SMART APPLICATOR	2161326-1	-	8-2151311-4	-	-	-
	2151311-2	D	FINE CRIMP HEIGHT ADJUST	PNEUMATIC	MECHANICAL FEED	2119949-1	1338685-1	5-18022-5	2119653-1	-	-
					SERVO LATCH PLATE	2119951-1	-	8-2151311-5	1901094-3	-	2168400-6 (QUANTITY 2)
					SMART APPLICATOR	2161326-1	-	8-2151311-4	-	-	-
	2151311-5	D	FINE CRIMP HEIGHT ADJUST	SERVO LATCH PLATE <sup>4</sup>	MECHANICAL FEED	2119949-1	1338685-1	5-18022-5	2119653-1	-	-
					PNEUMATIC FEED	2119950-1	1338685-1	5-18022-5	2119641-1	2119799-1	2063440-1
	2151311-6	D	NON-CRIMP HEIGHT ADJUST	SERVO LATCH PLATE <sup>4</sup>	-	-	-	-	-	-	-
					-	-	-	-	-	-	-
	2151311-7	D	FINE CRIMP HEIGHT ADJUST	NONE	-	-	-	-	-	-	-
					-	-	-	-	-	-	-
7-2151311-7	D	CRIMP TOOLING KIT	-	-	-	-	-	-	-	-	

APPLICATOR DATA		
CRIMP	SIZE	TYPE
WIRE	1.27 mm [.050]	F
INSUL	1.78 mm [.070]	O

APPLICATOR INSTRUCTIONS  
408-10389

TERMINAL DATA: TE TERMINAL		TE CRIMP SPECIFICATION	
TERMINAL NAME:	TAB CONTACT	1.2 x 0.6mm	
WIRE STRIP LENGTH		INSULATION DIAMETER RANGE	
3.00-3.60 mm [.118-.142 IN]		Ø1.10-1.75 mm [.043-.069 IN]	
TERMINAL APPLICATION SPECIFICATION	114-18464		
TERMINALS APPLIED			
TE TERMINAL	TE TERMINAL	TE TERMINAL	TE TERMINAL
1418758-1	1418758-3	5-1418758-2	
1418758-2	5-1418758-1	5-1418758-3	

WIRE SIZE	CRIMP HEIGHT mm [INCH]	CRIMP HEIGHT REFERENCE SETTING
0.35mm2	0.84+/-0.03 [.033+/-0.001]	5.5
22 AWG	0.83+/-0.03 [.033+/-0.001]	5.7
0.25mm2	0.78+/-0.03 [.031+/-0.001]	6.2
24 AWG	0.75+/-0.03 [.030+/-0.001]	6.5

- <sup>1</sup> RECOMMENDED SPARE PARTS
- <sup>2</sup> GREASE BEARING SURFACES LIGHTLY
- 3. LUBRICATE DAILY PER THE APPLICATOR INSTRUCTION SHEET SUPPLIED WITH THE APPLICATOR.
- <sup>4</sup> APPLICATOR SPECIFIC DATA TO BE ENTERED INTO BLANK MEMORY CHIP AT ASSEMBLY. SEE BELOW FOR PART NUMBER:  
MECHANICAL FEED WITH "SMART APPLICATOR" CONVERSION: 8-2151311-4  
PNEUMATIC FEED WITH "SMART APPLICATOR" CONVERSION: 8-2151311-4  
SERVO FEED WITH "FINE CRIMP HEIGHT ADJUST": 8-2151311-5  
SERVO FEED WITH "NON-CRIMP HEIGHT ADJUST": 8-2151311-6
- 5. ADJUSTMENT OF THE STRIPPER MAY BE REQUIRED WHEN MOVING THE APPLICATOR BETWEEN BENCH AND LEADMAKER APPLICATIONS.
- <sup>6</sup> APPLY PART NUMBER 1-23419-5 LOCTITE TO THREADS OF ITEMS 62. APPLY PART NUMBER 2-23419-6 LOCTITE TO THREADS OF ITEMS 242. FOR -6 ONLY APPLY PART NUMBER 1-23419-5 LOCTITE TO THREADS OF ITEM 37.
- <sup>7</sup> GREASE THREADS, GROOVE AND O-RING ON ITEMS 35 & 252.
- <sup>8</sup> MAGNET, ITEM 166 MUST BE ORIENTED CORRECTLY IN ORDER TO PROPERLY ACTUATE THE COUNTER.
- <sup>9</sup> CRIMP HEIGHT REFERENCE SETTING WAS THE SETTING USED WHEN THE APPLICATOR WAS QUALIFIED AT THE FACTORY. ADJUSTMENT MAY BE NECESSARY WHEN RUNNING APPLICATOR IN THE FIELD.
- <sup>10</sup> SPARE FEED CAM STORAGE LOCATION REFER TO INSTRUCTION SHEET FOR ADDITIONAL INFORMATION.
- <sup>11</sup> TO CONVERT THE APPLICATOR TO A NON-CARRIER CUTTING STYLE, REMOVE ITEM 13 AND ATTACH TO THE LOCATION ON THE BACK SIDE OF THE HOUSING. REFER TO INSTRUCTION SHEET FOR ADDITIONAL INFORMATION.
- <sup>12</sup> WHEN ASSEMBLING -6 NON-CRIMP HEIGHT ADJUST APPLICATOR USE SHIM PACK 2119957-2 TO ALIGN APPLICATOR'S MAXIMUM WIRE CRIMP HEIGHT AT NORMAL TERMINATOR SHUT HEIGHT

**\*WARNING**  
ON INSTALLATION, SET WIRE DISC, ITEM 40 TO LARGEST WIRE SIZE SETTING. USE OF SETTINGS BELOW MINIMUM REQUIRED CRIMP HEIGHT SETTING WILL CAUSE DAMAGE TO CRIMP TOOLING.

-77	-7	-6	-5	-2	-1	PART NO	DESCRIPTION	ITEM NO
-	-	1	-	-	-	2119957-2	APPLICATOR SHIM PACK	260

**ATLANTIC VERSION**  
Shown on sheets 1 of 4 & 2 of 4  
(Pacific version shown on sheets 3 of 4 & 4 of 4)

SET UP GAUGE	LOC	DIST	REVISIONS					
2119599-1	A	66	P	LTN	DESCRIPTION	DATE	OWN	APVD
			D		ECR-14-013912	18SEP2014	KH	GB

-	1	-	1	1	1	8-21084-0	O-RING, .676 ID, .070 DIA. MAT.	252
-	-	-	-	1	-	2119640-1	PUSH ROD, AIR FEED	250
-	-	-	-	1	-	2079988-1	BUSHING, LCH5-12, MISUMI	249
-	-	-	-	1	-	2119641-1	FEED CAM, AIR FEED	248
-	1	-	1	1	1	2119798-1	DETENT PIN	247
-	1	-	1	1	1	1-22279-3	SPRING, COMPRESSION	246
-	-	1	-	-	-	2119758-1	RAM, AMP STYLE, SIDE FEED, NON-ADJ.	245
-	1	1	1	1	1	2119082-5	CAM, SNAIL, INSULATION ADJUSTMENT	244
-	1	1	1	1	1	2079764-1	WASHER, WAVE SPRING, CREST-TO-CREST	243
-	1	1	1	1	1	2119083-1	RETAINER, INSULATION DIAL	242
-	1	1	1	1	1	7-18023-7	SCR, SKT HD CAP M3 X 4.0	241
-	-	2	2	-	-	2168400-6	SHCS, LOW HEAD, RoHS, M5 X 16	240
-	-	-	-	-	1	2119580-1	MECHANICAL FEED ASSEMBLY	239
-	-	-	-	-	1	2063440-1	AIR FEED MODULE	238
-	-	1	1	-	-	2119740-2	TAG, IDENTIFICATION	213
-	-	1	1	-	-	1901094-3	SPACER, FEEDER	198
-	-	-	-	-	2	21045-3	RING, RETAIN, EXTERN, 3/16 CRESCENT	172
-	1	1	1	1	1	994969-1	MAGNET, RARE EARTH HIGH ENERGY	166
-	REF	REF	REF	REF	REF	994970-2	COUNTER, MAGNETIC	164
-	-	-	-	1	-	240638-1	SPRING, FEED FINGER	163
-	-	-	-	1	-	3-23627-7	PIN, RETAIN, GRVD, 3/16 X .854	137
-	-	-	-	1	-	2119799-1	HOLDER, FEED FINGER, AF	136
-	-	REF	REF	-	-	SEE NOTE 4	MEMORY CHIP, PROGRAMMED	135
-	-	1	1	-	-	1633743-1	SERVO FEED LATCH ASM	133
-	-	REF	REF	-	-	2119944-1	FEED FINGER ASSEMBLY, SF	117
-	1	1	1	1	1	455888-6	SPACER, CRIMPER	82
-	1	1	1	1	1	2119956-1	DOCUMENTATION PACKAGE	71
-	1	1	1	1	1	2119791-5	DEPRESSOR, WIRE	70
-	1	-	-	1	1	2119740-1	TAG, IDENTIFICATION	67
-	2	2	2	2	2	2168078-1	SCREW, DRIVE, RH, RoHS, 2 x .188	66
-	1	-	1	1	1	2119793-1	LIMITER, ADJUSTMENT BOLT	63
-	3	-	3	3	3	992763-5	SCR, SET, SOC, CONE POINT, M3 x 4.0	62
-	1	1	1	1	1	2079383-4	SCR, BHSC, RoHS (M4 X 8)	60
-	-	-	-	1	1	5-18022-5	SCR, HEX HD CAP, M4 X 6.0	59
-	-	-	-	1	1	1338685-1	PAWL, FEED	56
-	4	4	4	4	4	2168400-1	SHCS, LOW HEAD, RoHS, M4 X 12	54
-	2	2	2	2	2	2168083-8	SCR, SKT HD CAP, RoHS, M4 X 16	53
-	1	1	1	1	1	5018030-1	NUT, HEX, REG, RoHS, M3	52
-	1	1	1	1	1	811242-5	BUMPER, HOLD DOWN	51
-	1	1	1	1	1	690753-2	SPACER, TONKER	50
-	-	-	-	-	1	18023-9	SCR, SKT HD CAP M4 X 6.0	49
-	-	-	-	-	1	2119652-1	FEED CAM, PRE FEED	48
-	-	-	-	-	1	2119653-1	FEED CAM, POST FEED	47
-	1	1	1	1	1	2119656-9	APPLICATOR BASIC ASSEMBLY, SF	46
-	1	-	1	1	1	2119370-1	RAM, AMP STYLE, SIDE FEED	44
-	1	1	1	1	1	2079383-7	SCR, BHSC, RoHS (M8 X 25)	41
-	1	-	1	1	1	2119645-1	DISC, NUMBERED FA WIRE ADJUSTMENT	40
-	1	-	1	1	1	2119957-1	APPLICATOR SHIM PACK	39
-	1	1	1	1	1	1-2119644-4	RAM WASHER, PRECISION	38
-	1	1	1	1	1	2119085-1	FA HEAD, ATLANTIC STYLE	37
-	1	-	1	1	1	2119092-1	BOLT, ADJUSTMENT	35
-	1	1	1	1	1	1752356-6	SUPPORT, TERMINAL	34
-	2	2	2	2	2	2079383-5	SCR, BHSC, RoHS (M4 X 20)	33
-	1	1	1	1	1	2161328-1	HEX HEAD, FLANGED, M5 x 8mm LONG	32
-	1	1	1	1	1	1320908-3	SPACER, STRIP GUIDE	30
-	1	1	1	1	1	2119959-2	ASSEMBLY, STRIP GUIDE	29
-	1	1	1	1	1	1320928-6	STRIP GUIDE	24
-	1	1	1	1	1	2168083-2	SCR, SKT HD CAP, RoHS, M4 X 8.0	21
-	2	2	2	2	2	1-18028-2	WASHER, FLAT, REG M4	20
-	1	1	1	1	1	2119533-1	STRIPPER, SIDE FEED	19
-	1	1	1	1	1	2119806-1	INSERT, SHEAR	13
-	1	1	1	1	1	3-22280-3	SPRING, COMPRESSION	12
-	1	1	1	1	1	1-356885-4	STOP, SHEAR	11
-	1	1	1	1	1	2119805-1	SHEAR HOLDER, FRONT	10
-	1	1	1	1	1	1803095-1	FLOATING SHEAR, FRONT	9
-	1	1	1	1	1	2-1333225-0	ANVIL, COMBINATION	8
-	1	1	1	1	1	3-240641-1	SPACER	7
-	-	-	-	-	-	-	-	6
-	1	1	1	1	1	2119757-6	DEPRESSOR, SHEAR	5
-	1	1	1	1	1	5-238011-2	BLOCK, CRIMPER SPACER	4
-	1	1	1	1	1	3-1633966-4	CRIMPER, INSULATION O	3
-	-	-	-	-	-	-	-	2
-	1	1	1	1	1	2-1490019-3	CRIMPER, WIRE PREMIUM	1

DIMENSIONS:		TOLERANCES UNLESS OTHERWISE SPECIFIED:		DATE	BY	CHKD	APPD	NAME
mm	0 PLC ±.05	1 PLC ±.05	2 PLC ±.05	16 JULY 2012	HOFFNER	HOFFNER	HOFFNER	TE Connectivity
	3 PLC ±.05	4 PLC ±.05	5 PLC ±.05	17 JULY 2012	G. BAILEY	G. BAILEY	G. BAILEY	Harrisburg, PA 17105-3608
	6 PLC ±.05	7 PLC ±.05	8 PLC ±.05					
	9 PLC ±.05	10 PLC ±.05	11 PLC ±.05					
	12 PLC ±.05	13 PLC ±.05	14 PLC ±.05					
	15 PLC ±.05	16 PLC ±.05	17 PLC ±.05					
	18 PLC ±.05	19 PLC ±.05	20 PLC ±.05					
	21 PLC ±.05	22 PLC ±.05	23 PLC ±.05					
	24 PLC ±.05	25 PLC ±.05	26 PLC ±.05					
	27 PLC ±.05	28 PLC ±.05	29 PLC ±.05					
	30 PLC ±.05	31 PLC ±.05	32 PLC ±.05					
	33 PLC ±.05	34 PLC ±.05	35 PLC ±.05					
	36 PLC ±.05	37 PLC ±.05	38 PLC ±.05					
	39 PLC ±.05	40 PLC ±.05	41 PLC ±.05					
	42 PLC ±.05	43 PLC ±.05	44 PLC ±.05					
	45 PLC ±.05	46 PLC ±.05	47 PLC ±.05					
	48 PLC ±.05	49 PLC ±.05	50 PLC ±.05					
	51 PLC ±.05	52 PLC ±.05	53 PLC ±.05					
	54 PLC ±.05	55 PLC ±.05	56 PLC ±.05					
	57 PLC ±.05	58 PLC ±.05	59 PLC ±.05					
	60 PLC ±.05	61 PLC ±.05	62 PLC ±.05					
	63 PLC ±.05	64 PLC ±.05	65 PLC ±.05					
	66 PLC ±.05	67 PLC ±.05	68 PLC ±.05					
	69 PLC ±.05	70 PLC ±.05	71 PLC ±.05					
	72 PLC ±.05	73 PLC ±.05	74 PLC ±.05					
	75 PLC ±.05	76 PLC ±.05	77 PLC ±.05					
	78 PLC ±.05	79 PLC ±.05	80 PLC ±.05					
	81 PLC ±.05	82 PLC ±.05	83 PLC ±.05					
	84 PLC ±.05	85 PLC ±.05	86 PLC ±.05					
	87 PLC ±.05	88 PLC ±.05	89 PLC ±.05					
	90 PLC ±.05	91 PLC ±.05	92 PLC ±.05					
	93 PLC ±.05	94 PLC ±.05	95 PLC ±.05					
	96 PLC ±.05	97 PLC ±.05	98 PLC ±.05					
	99 PLC ±.05	100 PLC ±.05	101 PLC ±.05					
	102 PLC ±.05	103 PLC ±.05	104 PLC ±.05					
	105 PLC ±.05	106 PLC ±.05	107 PLC ±.05					
	108 PLC ±.05	109 PLC ±.05	110 PLC ±.05					
	111 PLC ±.05	112 PLC ±.05	113 PLC ±.05					
	114 PLC ±.05	115 PLC ±.05	116 PLC ±.05					
	117 PLC ±.05	118 PLC ±.05	119 PLC					

REVISONS		DATE	OWN	APVD
A	66	-	-	-
SEE SHEET 1				

### FEED TYPE MECHANICAL

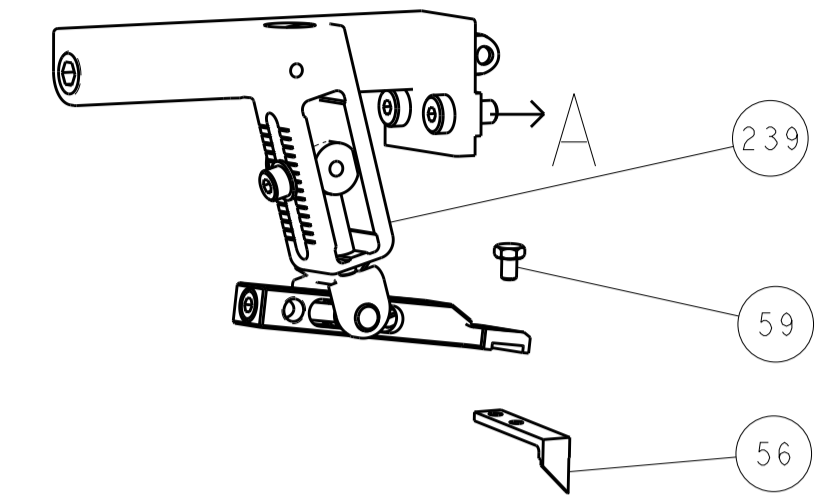

### PNEUMATIC

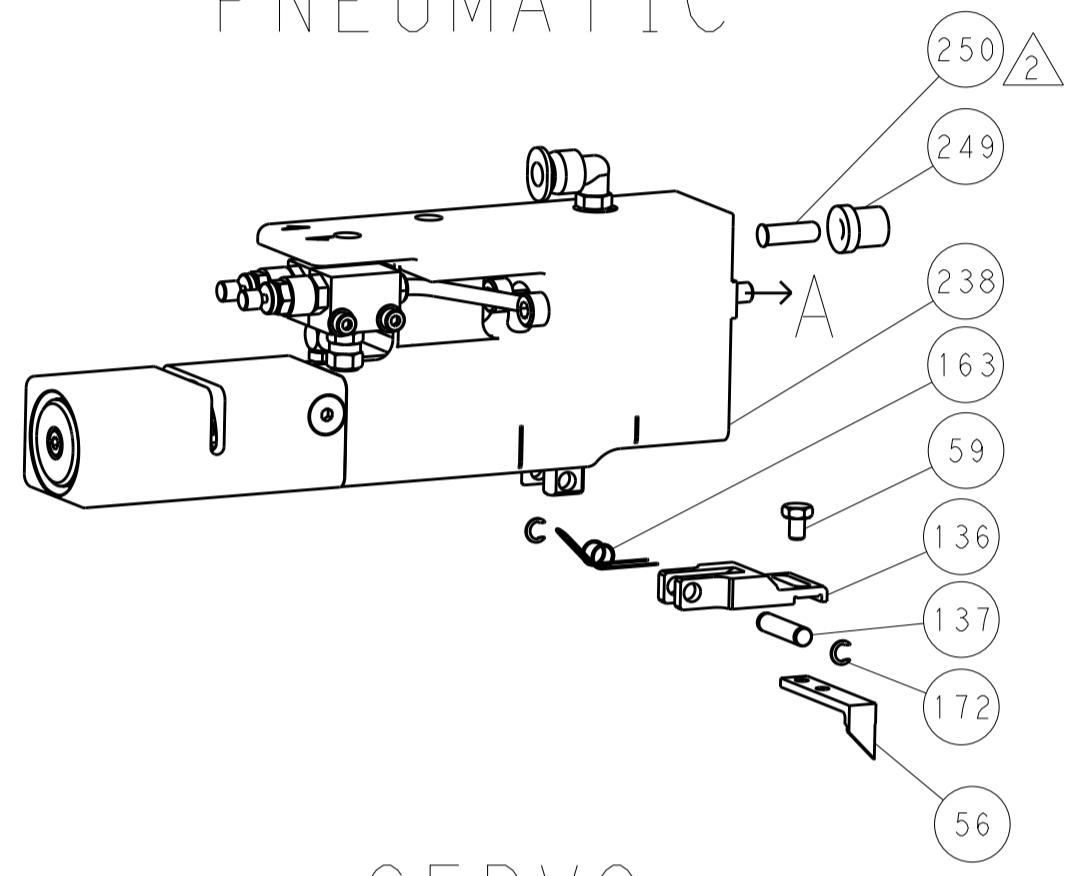

### SERVO LATCH PLATE



### CAM POSITIONS

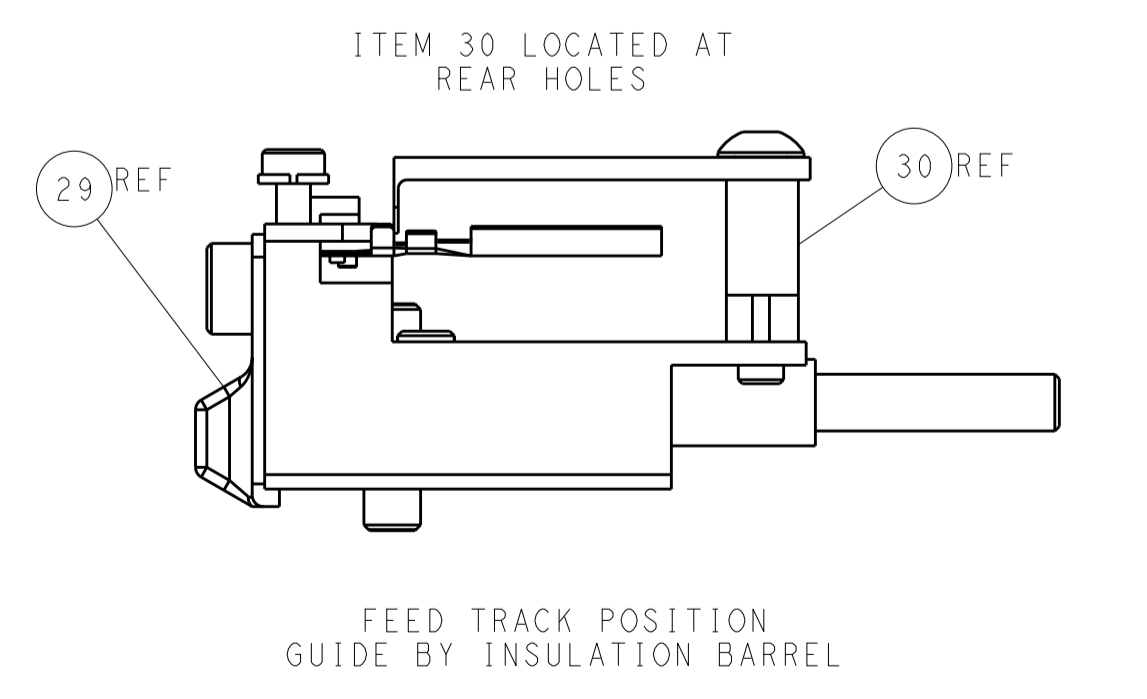
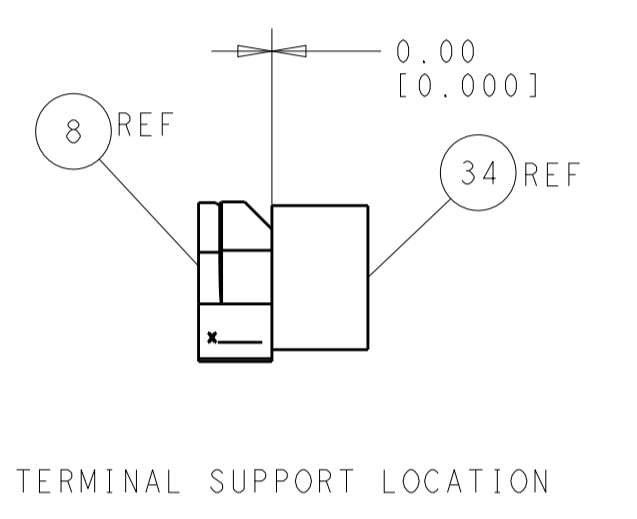
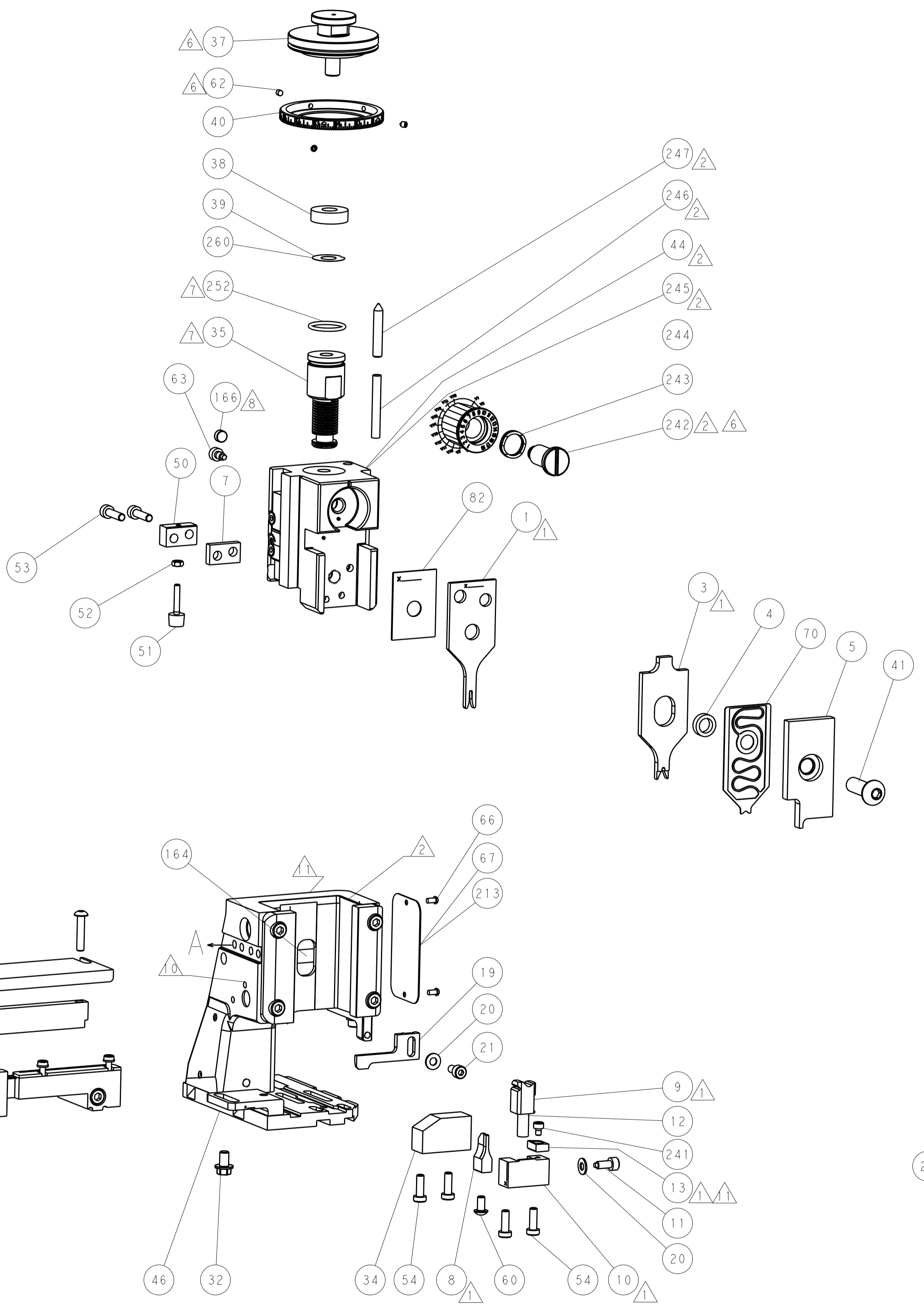

**ATLANTIC VERSION**  
 Shown on sheets 1 of 4 & 2 of 4  
 (Pacific version shown on sheets 3 of 4 & 4 of 4)

DIMENSIONS:		TOLERANCES UNLESS OTHERWISE SPECIFIED:		DWN: HOFFNER 16JULY2012		TE Connectivity	
mm	0 PLC ±0.5	1 PLC ±0.5	2 PLC ±0.13	3 PLC ±0.013	4 PLC ±0.013	CHG: G. BAILEY 17JULY2012	Harrisburg, PA 17105-3608
MATERIAL:		FINISH:		NAME: Ocean Side Feed Applicator		RESTRICTED TO:	
Customer Accessible Production Drawing		SCALE: 1:2		SHEET 2 of 4		REV D	

PACIFIC VERSION TERMINATOR INTERFACE ADAPTER	PART NUMBER	REVISION	DESCRIPTION	FEED TYPE	APPLICATOR STYLE CONVERSION CHART						
					CONVERT TO	PART NUMBERS REQUIRED					
	2-2151311-1	D	FINE CRIMP HEIGHT ADJUST	MECHANICAL	PNEUMATIC FEED	2119950-1	1338685-1	5-18022-5	2119641-2	2119799-1	2063440-1
					SERVO LATCH PLATE	2119951-1	-	8-2151311-5	1901094-3	-	2168400-6 (QUANTITY 2)
					SMART APPLICATOR	2161326-1	-	8-2151311-4	-	-	-
	2-2151311-2	D	FINE CRIMP HEIGHT ADJUST	PNEUMATIC	MECHANICAL FEED	2119949-1	1338685-1	5-18022-5	2119653-2	-	-
					SERVO LATCH PLATE	2119951-1	-	8-2151311-5	1901094-3	-	2168400-6 (QUANTITY 2)
					SMART APPLICATOR	2161326-1	-	8-2151311-4	-	-	-
	2-2151311-5	D	FINE CRIMP HEIGHT ADJUST	SERVO LATCH PLATE <sup>4</sup>	MECHANICAL FEED	2119949-1	1338685-1	5-18022-5	2119653-2	-	-
					PNEUMATIC FEED	2119950-1	1338685-1	5-18022-5	2119641-2	2119799-1	2063440-1
	2-2151311-7	D	FINE CRIMP HEIGHT ADJUST	NONE	-	-	-	-	-	-	-
	7-2151311-7	D	CRIMP TOOLING KIT	-	-	-	-	-	-	-	-

APPLICATOR DATA		
CRIMP	SIZE	TYPE
WIRE	1.27 mm [.050]	F
INSUL	1.78 mm [.070]	O
APPLICATOR INSTRUCTIONS 408-10389		

TERMINAL DATA: TE TERMINAL		TE CRIMP SPECIFICATION	
TERMINAL NAME: TAB CONTACT 1.2 x 0.6mm			
WIRE STRIP LENGTH		INSULATION DIAMETER RANGE	
3.00-3.60 mm [1.18-.142 IN]		Ø1.10-1.75 mm [.043-.069 IN]	
TERMINAL APPLICATION SPECIFICATION	114-18464	-	-
TERMINALS APPLIED			
TE TERMINAL	TE TERMINAL	TE TERMINAL	TE TERMINAL
1418758-1	1418758-3	5-1418758-2	
1418758-2	5-1418758-1	5-1418758-3	

WIRE SIZE	CRIMP HEIGHT mm [INCH]	CRIMP HEIGHT REFERENCE SETTING
0.35mm2	0.84 +/- 0.03 [.033 +/- .001]	5.5
22 AWG	0.83 +/- 0.03 [.033 +/- .001]	5.7
0.25mm2	0.78 +/- 0.03 [.031 +/- .001]	6.2
24 AWG	0.75 +/- 0.03 [.030 +/- .001]	6.5

- RECOMMENDED SPARE PARTS
- GREASE BEARING SURFACES LIGHTLY
- 3. LUBRICATE DAILY PER THE APPLICATOR INSTRUCTION SHEET SUPPLIED WITH THE APPLICATOR.
- APPLICATOR SPECIFIC DATA TO BE ENTERED INTO BLANK MEMORY CHIP AT ASSEMBLY. SEE BELOW FOR PART NUMBER:  
 MECHANICAL FEED WITH "SMART APPLICATOR" CONVERSION: 8-2151311-4  
 PNEUMATIC FEED WITH "SMART APPLICATOR" CONVERSION: 8-2151311-4  
 SERVO FEED WITH "FINE CRIMP HEIGHT ADJUST": 8-2151311-5
- 5. ADJUSTMENT OF THE STRIPPER MAY BE REQUIRED WHEN MOVING THE APPLICATOR BETWEEN BENCH AND LEADMAKER APPLICATIONS.
- APPLY PART NUMBER 1-23419-5 LOCTITE TO THREADS OF ITEMS 62. APPLY PART NUMBER 2-23419-6 LOCTITE TO THREADS OF ITEMS 242.
- GREASE THREADS, GROOVE AND O-RING ON ITEMS 139 & 152.
- MAGNET MUST BE ORIENTED CORRECTLY IN ORDER TO PROPERLY ACTUATE THE COUNTER.
- CRIMP HEIGHT REFERENCE SETTING WAS THE SETTING USED WHEN THE APPLICATOR WAS QUALIFIED AT THE FACTORY. ADJUSTMENT MAY BE NECESSARY WHEN RUNNING APPLICATOR IN THE FIELD.
- SPARE FEED CAM STORAGE LOCATION REFER TO INSTRUCTION SHEET FOR ADDITIONAL INFORMATION.
- TO CONVERT THE APPLICATOR TO A NON-CARRIER CUTTING STYLE, REMOVE ITEM 13 AND ATTACH TO THE LOCATION ON BACK SIDE OF THE HOUSING. REFER TO INSTRUCTION SHEET FOR ADDITIONAL INFORMATION.

**\*WARNING**  
 ON INSTALLATION, SET WIRE DISC, ITEM 40 TO LARGEST WIRE SIZE SETTING. USE OF SETTINGS BELOW MINIMUM REQUIRED CRIMP HEIGHT SETTING WILL CAUSE DAMAGE TO CRIMP TOOLING.

**PACIFIC VERSION**  
 Shown on sheets 3 of 4 & 4 of 4  
 (Atlantic version shown on sheets 1 of 4 & 2 of 4)

SET UP GAUGE	LOC	DIST	REVISIONS			
2119599-1	A	66	REV	DATE	BY	APPD
			-	SEE SHEET 1	-	-

-	1	1	1	1	2119782-1	FINE ADJUST HEAD ASM, PACIFIC STYLE	251	
-	-	-	1	-	2119640-1	PUSH ROD, AIR FEED	250	
-	-	-	1	-	2079988-1	BUSHING, LCH5-12, MISUMI	249	
-	1	1	1	1	1-22279-3	SPRING, COMPRESSION	246	
-	1	1	1	1	2119082-5	CAM, SNAIL, INSULATION ADJUSTMENT	244	
-	1	1	1	1	2079764-1	WASHER, WAVE SPRING, CREST-TO-CREST	243	
-	1	1	1	1	2119083-1	RETAINER, INSULATION DIAL	242	
-	1	1	1	1	7-18023-7	SCR, SKT HD CAP M3 X 4.0	241	
-	-	2	-	-	2168400-6	SHCS, LOW HEAD, RoHS, M5 X 16	240	
-	-	-	-	1	2119580-1	MECHANICAL FEED ASSEMBLY	239	
-	-	-	1	-	2063440-1	AIR FEED MODULE	238	
-	-	1	-	-	2119740-2	TAG, IDENTIFICATION	213	
-	-	1	-	-	1901094-3	SPACER, FEEDER	198	
-	-	-	2	-	21045-3	RING, RETAIN, EXTERN, 3/16 CRESCENT	172	
-	1	1	1	1	994969-1	MAGNET, RARE EARTH HIGH ENERGY	166	
-	REF	REF	REF	REF	994970-2	COUNTER, MAGNETIC	164	
-	-	-	1	-	240638-1	SPRING, FEED FINGER	163	
-	1	1	1	1	8-21084-1	O-RING, .801 ID, .070 DIA. MAT.	152	
-	-	-	1	-	2119641-2	FEED CAM, AIR FEED	151	
-	1	1	1	1	2119798-2	DETENT PIN	145	
-	1	1	1	1	2079383-8	SCR, BHSC, RoHS (M4 X 16)	144	
-	4	4	4	4	2168400-5	SHCS, LOW HEAD, RoHS, M4 X 20	143	
-	-	-	-	1	2119653-2	FEED CAM, POST FEED	142	
-	1	1	1	1	1-2119656-0	APPLICATOR BASIC ASSEMBLY, SF	141	
-	1	1	1	1	2119650-1	RAM, ASIAN STYLE, SIDE FEED	140	
-	1	1	1	1	2119092-2	BOLT, ADJUSTMENT	139	
-	-	-	1	-	3-23627-7	PIN, RETAIN, GRVD, 3/16 X .854	137	
-	-	-	1	-	2119799-1	HOLDER, FEED FINGER, AF	136	
-	-	REF	-	-	SEE NOTE 4	MEMORY CHIP, PROGRAMMED	135	
-	-	1	-	-	1633743-1	SERVO FEED LATCH ASM	133	
-	-	REF	-	-	2119944-1	FEED FINGER ASSEMBLY, SF	117	
-	1	1	1	1	455888-6	SPACER, CRIMPER	82	
-	1	1	1	1	2119956-1	DOCUMENTATION PACKAGE	71	
-	1	1	1	1	2119791-5	DEPRESSOR, WIRE	70	
-	1	-	1	1	2119740-1	TAG, IDENTIFICATION	67	
-	2	2	2	2	2168078-1	SCREW, DRIVE, RH, RoHS, 2 x .188	66	
-	1	1	1	1	2119793-1	LIMITER, ADJUSTMENT BOLT	63	
-	3	3	3	3	992763-5	SCR, SET, SOC, CONE POINT, M3 X 4.0	62	
-	-	-	1	1	5-18022-5	SCR, HEX HD CAP, M4 X 6.0	59	
-	-	-	1	1	1338685-1	PAWL, FEED	56	
-	2	2	2	2	2168083-8	SCR, SKT HD CAP, RoHS, M4 X 16	53	
-	1	1	1	1	5018030-1	NUT, HEX, REG, RoHS, M3	52	
-	1	1	1	1	811242-5	BUMPER, HOLD DOWN	51	
-	1	1	1	1	690753-2	SPACER, TONKER	50	
-	-	-	1	2	18023-9	SCR, SKT HD CAP M4 X 6.0	49	
-	-	-	-	1	2119652-1	FEED CAM, PRE FEED	48	
-	1	1	1	1	2079383-7	SCR, BHSC, RoHS (M8 X 25)	41	
-	1	1	1	1	2119645-1	DISC, NUMBERED FA WIRE ADJUSTMENT	40	
-	1	1	1	1	2119957-1	APPLICATOR SHIM PACK	39	
-	1	1	1	1	1-2119644-4	RAM WASHER, PRECISION	38	
-	1	1	1	1	1752356-6	SUPPORT, TERMINAL	34	
-	2	2	2	2	2079383-5	SCR, BHSC, RoHS (M4 X 20)	33	
-	1	1	1	1	2161328-1	HEX HEAD, FLANGED, M5 X 8mm LONG	32	
-	1	1	1	1	1320908-3	SPACER, STRIP GUIDE	30	
-	1	1	1	1	2119959-2	ASSEMBLY, STRIP GUIDE	29	
-	1	1	1	1	1320928-6	STRIP GUIDE	24	
-	1	1	1	1	2168083-2	SCR, SKT HD CAP, RoHS, M4 X 8.0	21	
-	2	2	2	2	1-18028-2	WASHER, FLAT, REG M4	20	
-	1	1	1	1	2119533-1	STRIPPER, SIDE FEED	19	
-	1	1	1	1	2119806-1	INSERT, SHEAR	13	
-	1	1	1	1	3-22280-3	SPRING, COMPRESSION	12	
-	1	1	1	1	1-356885-4	STOP, SHEAR	11	
-	1	1	1	1	2119805-1	SHEAR HOLDER, FRONT	10	
-	1	1	1	1	1803095-1	FLOATING SHEAR, FRONT	9	
-	1	1	1	1	2-1333225-0	ANVIL, COMBINATION	8	
-	1	1	1	1	3-240641-1	SPACER	7	
-	-	-	-	-	-	-	6	
-	1	1	1	1	2119757-6	DEPRESSOR, SHEAR	5	
-	1	1	1	1	5-238011-2	BLOCK, CRIMPER SPACER	4	
-	1	1	1	1	3-1633966-4	CRIMPER, INSULATION O	3	
-	-	-	-	-	-	-	2	
-	1	1	1	1	2-1490019-3	CRIMPER, WIRE PREMIUM	1	
-	77	27	25	22	21	PART NO	DESCRIPTION	ITEM NO

DIMENSIONS:		TOLERANCES UNLESS OTHERWISE SPECIFIED:		DATE	BY	APPD	REV
mm	0 PLC ±.5	1 PLC ±0.5	2 PLC ±0.13	16 JULY 2012	HOFFNER		
	3 PLC ±0.013	4 PLC ±.5	ANGLES ±.0030	17 JULY 2012	G. BAILEY		
MATERIAL	FINISH						

NAME	SIZE	CAGE CODE	DRAWING NO	RESTRICTED TO
Ocean Side Feed Applicator	A1	00779	2151311	

Customer Accessible Production Drawing SCALE 1:2 SHEET 3 OF 4 REV D

LOC		DIST		REVISIONS			
A	66	P	LTM	DESCRIPTION	DATE	OWN	APVD
		-		SEE SHEET 1			

# FEED TYPE MECHANICAL

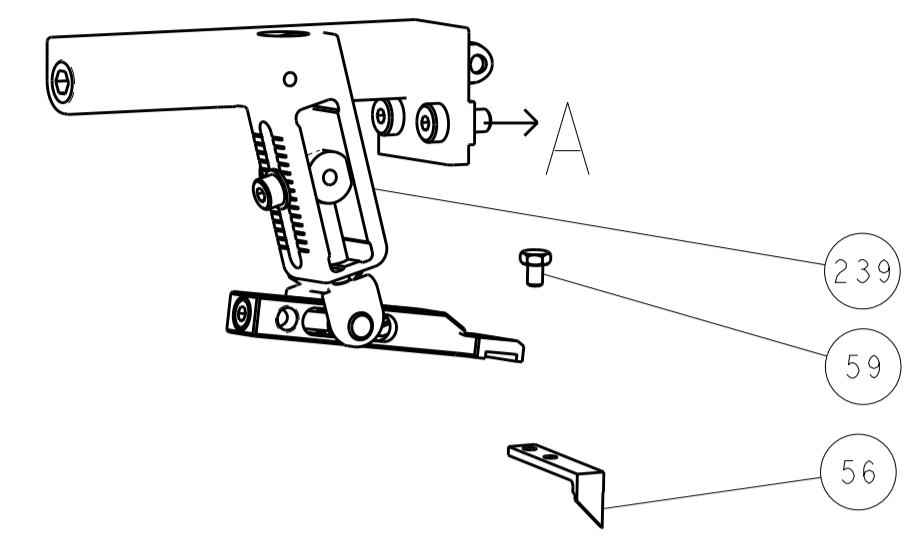

# PNEUMATIC

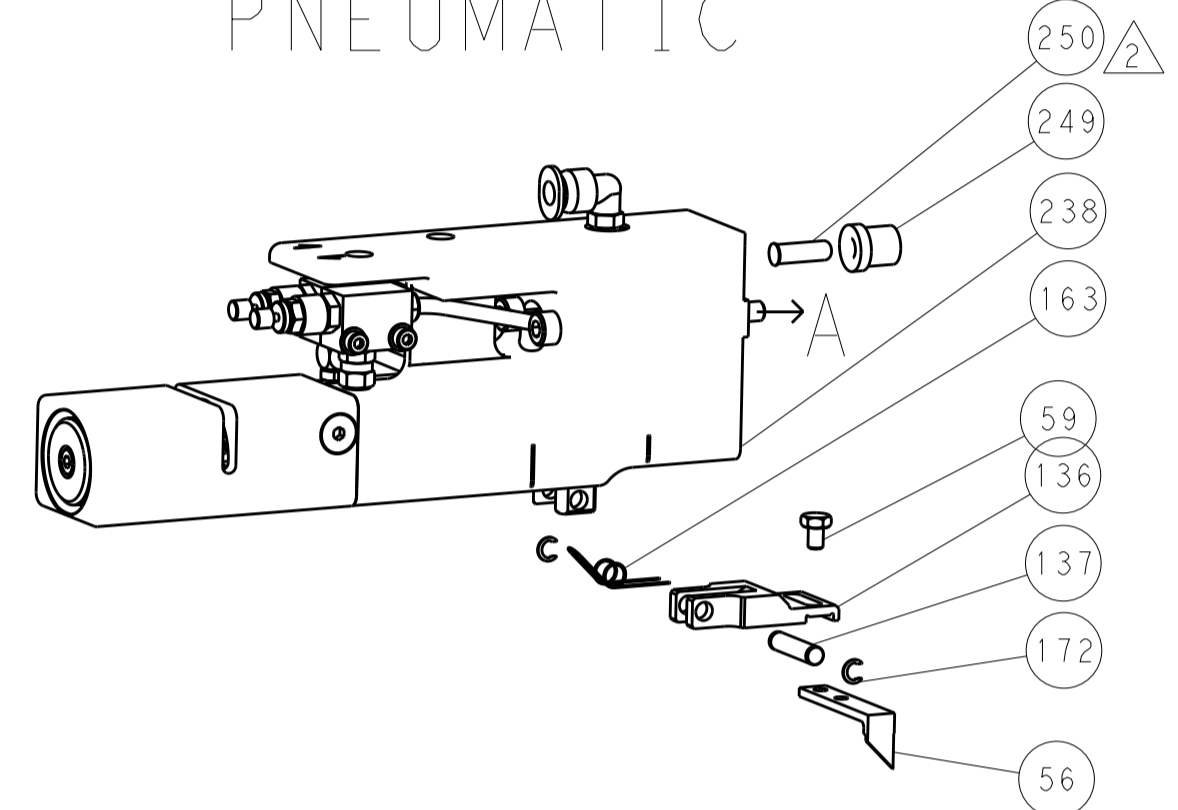

# SERVO LATCH PLATE



# CAM POSITIONS

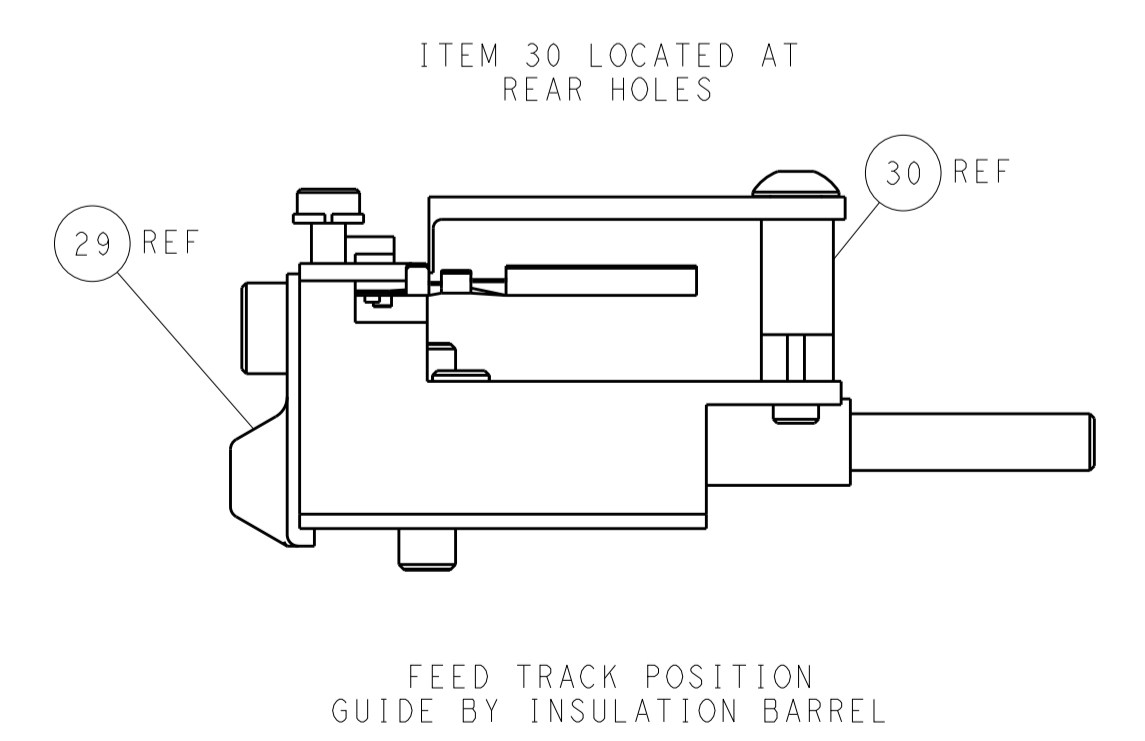
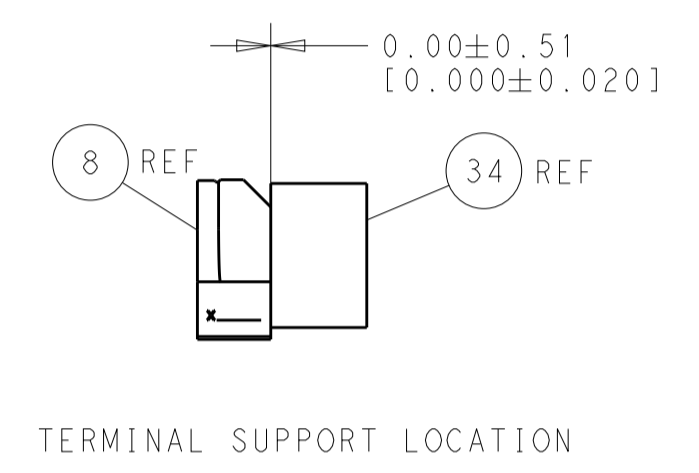
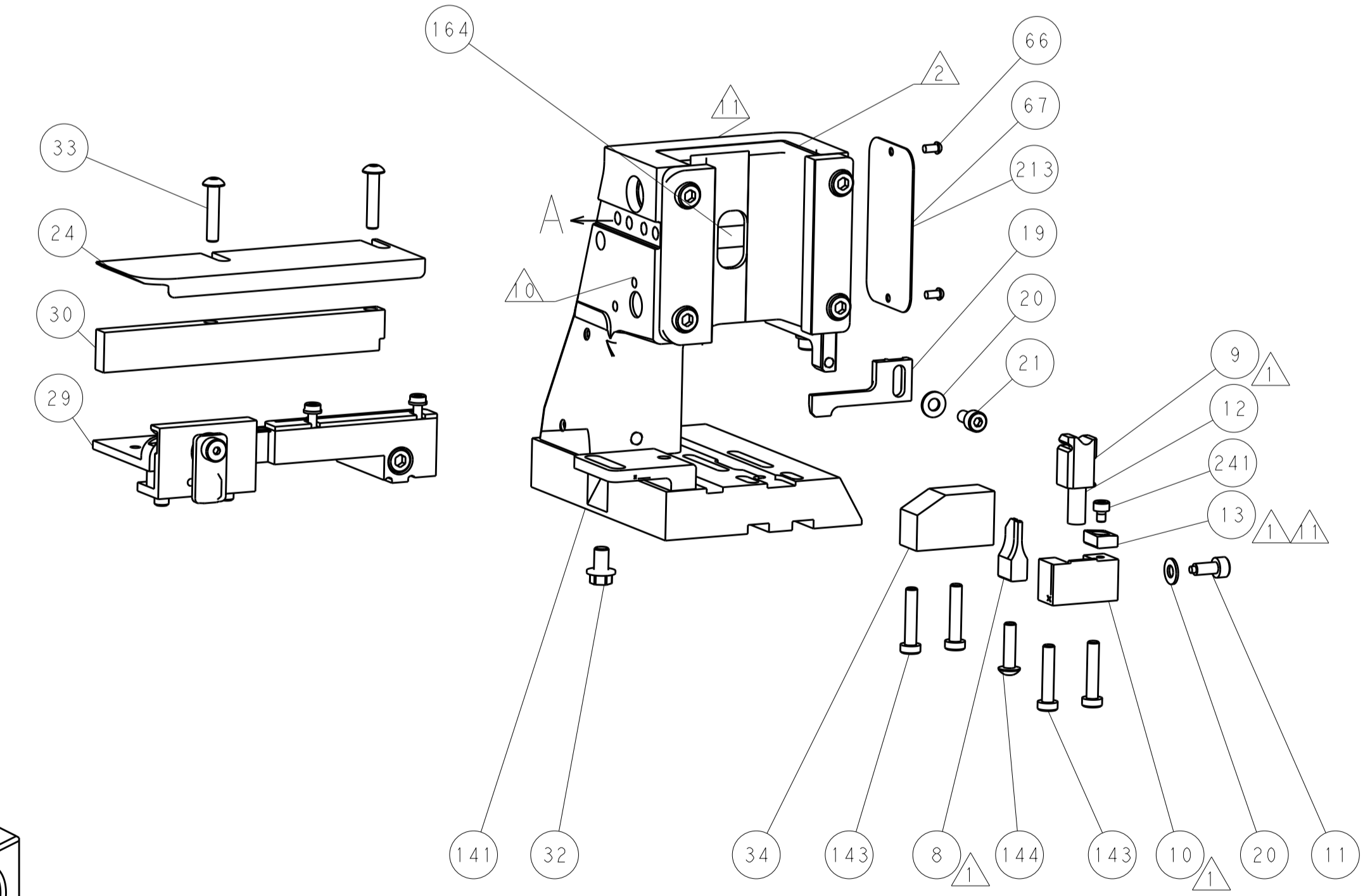
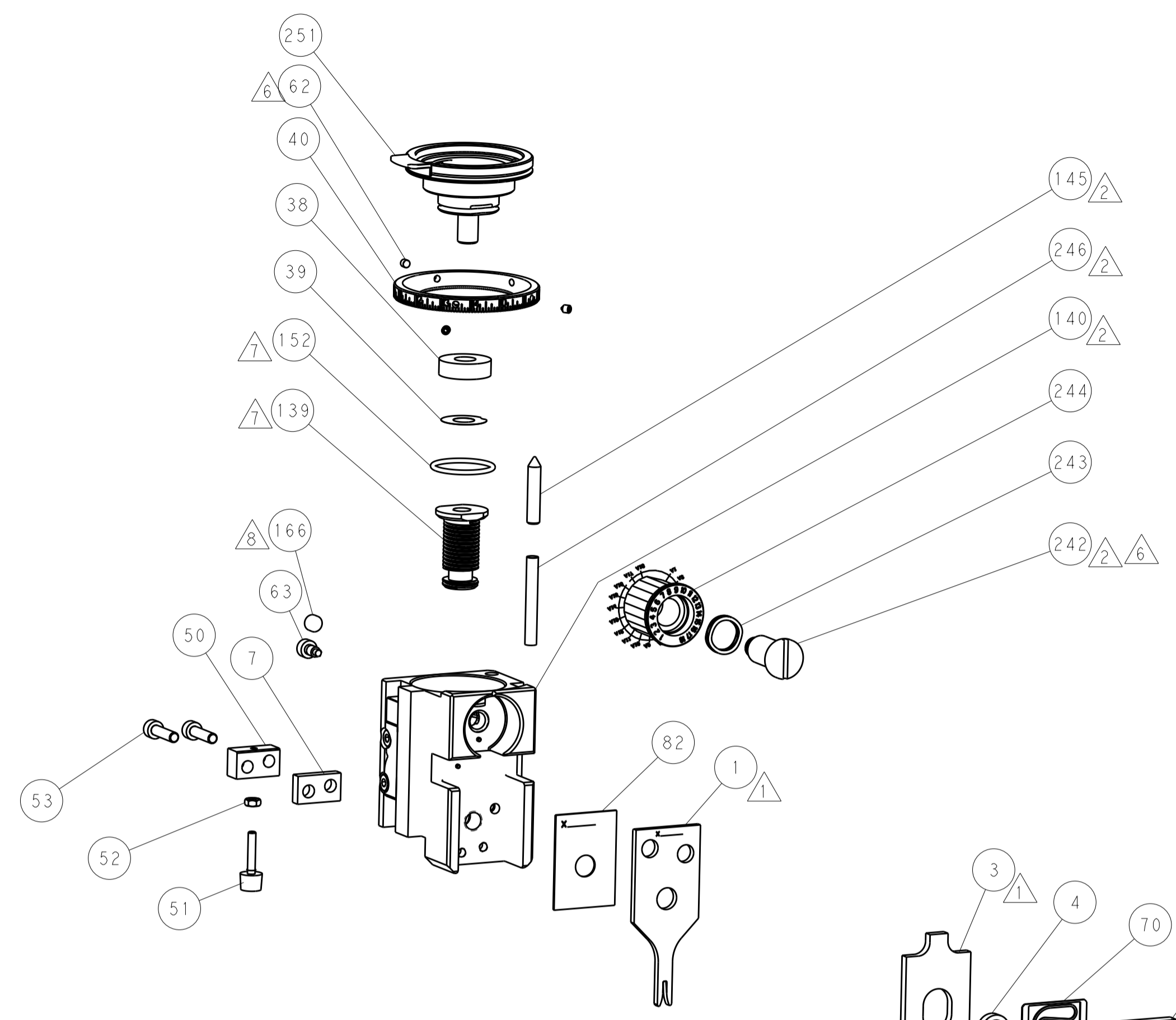

**PACIFIC VERSION**  
 Shown on sheets 3 of 4 & 4 of 4  
 (Atlantic version shown on sheets 1 of 4 & 2 of 4)

<small>THIS DRAWING IS UNPUBLISHED. RELEASED FOR PUBLICATION. IT IS THE PROPERTY OF TYCO ELECTRONICS CORPORATION. IT IS SUBJECT TO CHANGE AND WITHOUT WARRANTY OF MERCHANTABILITY. SHOULD BE CONTACTED FOR THE LATEST REVISION.</small>		DWN: HOFFNER 16JULY2012 CHK: G. BAILEY 17JULY2012 APVD: G. BAILEY 17JULY2012	NAME: TE Connectivity Harrisburg, PA 17105-3608
DIMENSIONS: mm 0 PLC ±0.5 1 PLC ±0.5 2 PLC ±0.13 3 PLC ±0.013 4 PLC ±0.013 ANGLES: ±0° 30'	TOLERANCES UNLESS OTHERWISE SPECIFIED: ±0.5 ±0.13 ±0.013 ±0° 30'	PRODUCT SPEC: APPLICATION SPEC: WEIGHT:	SIZE: CAGE CODE: DRAWING NO: 00779 ©=2151311 RESTRICTED TO:
MATERIAL:		Customer Accessible Production Drawing SCALE: 1:2 SHEET 4 OF 4 REV D	