

THIS DRAWING IS UNPUBLISHED. RELEASED FOR PUBLICATION ,19 .

© COPYRIGHT 19 BY AMP INCORPORATED. ALL RIGHTS RESERVED.

LOC	DIST	REVISIONS			
P	LTR	DESCRIPTION	DATE	DWN	APVD
G	14	C	REV / 0720-0967-96	09SEP96	ME TM

AMP WIRE RANGE	E13288	LR7189 Certified
16-14 AWG SOLID OR STRANDED	16-14 AWG SOLID OR STRANDED	16-14 AWG SOLID OR STRANDED

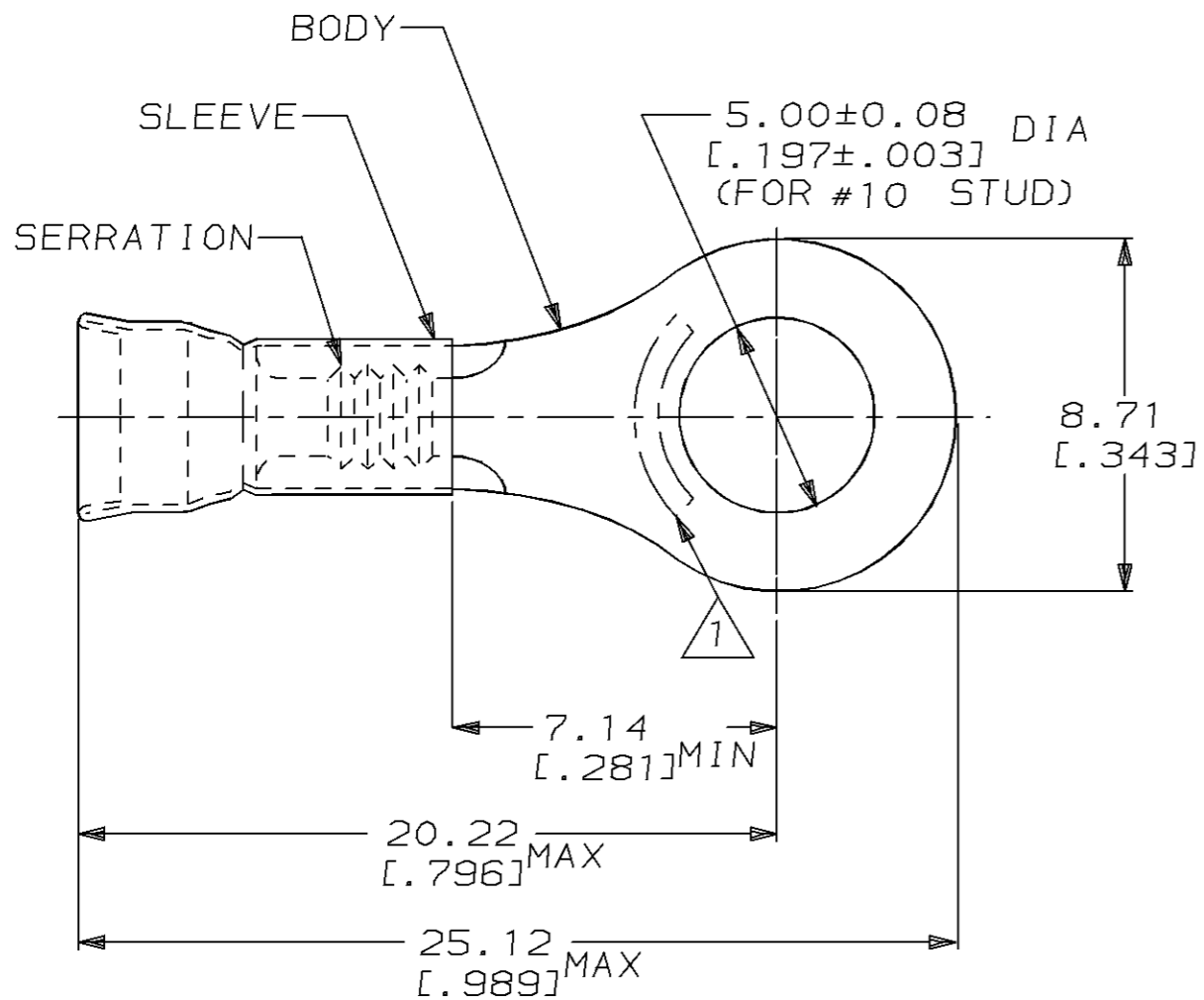

1. STAMP AMP 16-14HD* LOCATE APPROX AS SHOWN

- 2. WIRE INSUL DIA, 3.81-5.84 [.150-.230]
- 3. TONGUE MATL THK, 1.22±0.05 [.048±.002]

2500	ON TAPE, REEL	2-33722-1
500	LOOSE PIECE	33722
QTY	PACKAGE TYPE	PART NO

AMP INCORPORATED CUSTOMER SERVICE SYSTEM		MAX RECOMMENDED OPERATING TEMPERATURE: 170°C [338°F]	THIS DRAWING IS A CONTROLLED DOCUMENT FOR AMP INCORPORATED. IT IS SUBJECT TO CHANGE AND THE CONTROLLING ENGINEERING ORGANIZATION SHOULD BE CONTACTED FOR THE LATEST REVISION.		DWN L OLMEDA 23JAN95	AMP AMP Incorporated Harrisburg, PA 17105-3608
FOR ADDITIONAL PRODUCT INFORMATION OR COPIES OF DRAWINGS AND TECHNICAL DOCUMENTS	PRODUCT INFORMATION CENTER 1-800-522-6752		DIMENSIONS: mm [in]	TOLERANCES UNLESS OTHERWISE SPECIFIED:	CHK M ELLIS 23JAN95	
FOR APPLICATION TOOLING INFORMATION	TOOLING ASSISTANCE CENTER 1-800-722-1111	VOLTAGE RATING: -		0 PLC ±-	PRODUCT SPEC UL486A	NAME TERMINAL, RING, DIAMOND GRIP, WIRE SIZE, 16-14HD AWG
FOR ORDER ENTRY	1-800-526-5142	CIRCULAR MIL AREA: 1.04mm ² -2.62mm ² [2050-5180]	MATERIAL BODY, CU, SLV, CU PER ASTM B152	1 PLC ±- 2 PLC ±0.20 [.008] 3 PLC ±- 4 PLC ±- ANGLES ±-	APPLICATION SPEC -	SIZE A3
				FINISH TIN PLATE PER MIL-T-10727	WEIGHT -	CAGE CODE 00779
					CUSTOMER DRAWING	DRAWING NO C-33722
						SCALE 4:1
						SHEET 1 OF 1
						REV C