

UNCONTROLLED DOCUMENT

PART NUMBER
 SSP-LXC06767A-N57
 REV.

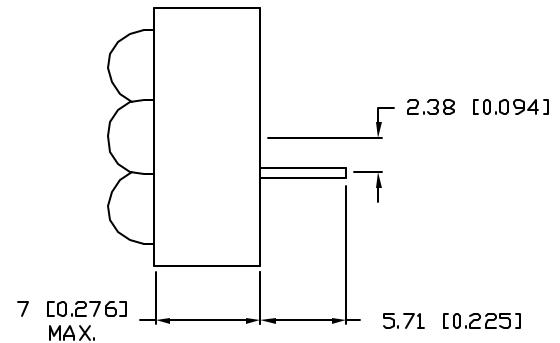
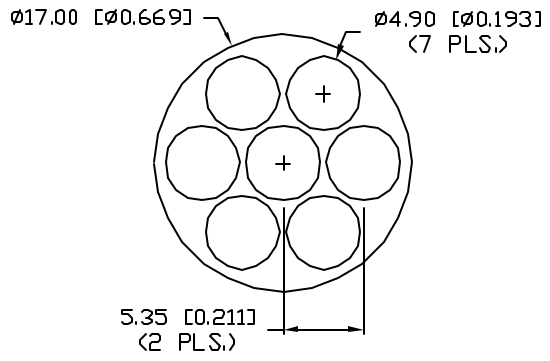

ELECTRO-OPTICAL CHARACTERISTICS $T_A=25^{\circ}\text{C}$ $I_f=20/40\text{mA}$

PARAMETER	MIN	TYP	MAX	UNITS	TEST COND
PEAK WAVELENGTH		660		nm	
FORWARD VOLTAGE**		5.4/3.6	6.9/4.6	V_f	
REVERSE VOLTAGE	4.0			V_r	$I_r=100\mu\text{A}$
AXIAL INTENSITY *		2000		mcd	$I_f=20/40\text{mA}$
VIEWING ANGLE		30		2x theta	
EMITTED COLOR:	SUPER RED				
EPOXY LENS FINISH:	WATER CLEAR				

* INTENSITY PER DIE.
 **VOLTAGE FOR PIN 1/PIN 3

LIMITS OF SAFE OPERATION AT 25°C PER DIE

PARAMETER	MAX	UNITS
PEAK FORWARD CURRENT*	150	mA
STEADY CURRENT	30	mA
POWER DISSIPATION	100	mW
DERATE FROM 25°C	-1.2	mW/°C
OPERATING, STORAGE TEMP.	-30 TO +70	°C
SOLDERING TEMP.	+260	°C
2.0mm FROM BODY		3 SEC. MAX

* $t < 10\mu\text{s}$

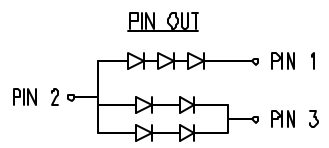
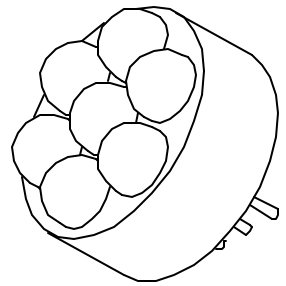
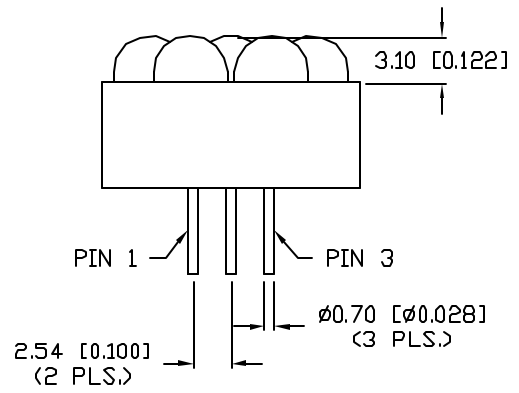

*UNLESS OTHERWISE SPECIFIED TOLERANCES PER DECIMAL PRECISION ARE: X=±1 (±0.039), X.X=±0.5 (±0.020), X.XX=±0.25 (±0.010), X.XXX=±0.127 (±0.005). LEAD SIZE=±0.05 (±0.002), LEAD LENGTH=±0.75 (±0.030), MIN.=^{+0.00}/_{-0.00} MAX.=^{+0.00}/_{-0.00}

UNCONTROLLED DOCUMENT

REV. PART NUMBER
 SSP-LXC06767A-N57

CONFIDENTIAL INFORMATION
 THE INFORMATION CONTAINED IN THIS DOCUMENT IS THE PROPERTY OF LUMEX INC. EXCEPT AS SPECIFICALLY AUTHORIZED IN WRITING BY LUMEX INC, THE HOLDER OF THIS DOCUMENT SHALL KEEP ALL INFORMATION CONTAINED HEREIN CONFIDENTIAL AND SHALL PROTECT SAME IN WHOLE OR IN PART FROM DISCLOSURE AND DISSEMINATION TO ALL THIRD PARTIES.

LUMEX INCORPORATED
 290 E. HELLEN ROAD
 PALATINE, ILLINOIS 60067
 PHONE: (847) 359-2790
 WEB: <http://www.lumex.com>

0.67" CIRCULAR, 7 LAMP POLY-LED,
 NO INSULATION ON LEADS, 0.225" LEAD LENGTH,
 660nm SUPER RED LEDS, WATER CLEAR LENS.

RELIABILITY NOTE
 OUR MANY YEARS OF EXPERIENCE DATA ACCUMULATION INDICATE THAT SOLDER HEAT IS A MAJOR CAUSE OF EARLY AND FUTURE FAILURE. PLEASE PAY ATTENTION TO YOUR SOLDERING PROCESS.

DRAWN BY: KS/BC	CHECKED BY:	APPROVED BY:	DATE: 9.20.00
			PAGE: 1 OF 1
			SCALE: N/A