

Development Board EPC9048 Quick Start Guide

*Half Bridge with Gate Drive
for EPC2034*

Revision 1.0

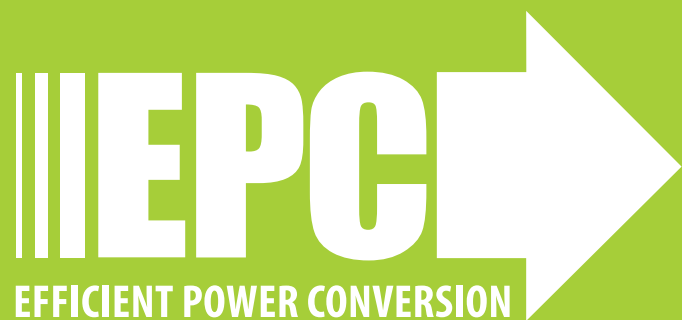

DESCRIPTION

The EPC9048 development boards are in a half bridge topology with onboard gate drives, featuring the EPC2034 eGaN® field effect transistors (FETs). The purpose of these development boards is to simplify the evaluation process of these eGaN FETs by including all the critical components on a single board that can be easily connected into any existing converter.

The development board is 2" x 1.5" and contains two eGaN FETs in a half bridge configuration using the Texas Instruments UCC27611 gate driver, supply and bypass capacitors. The board contains all critical components and layout for optimal switching performance. There are also various probe points to facilitate simple waveform measurement and efficiency calculation. A complete block diagram of the circuit is given in Figure 1.

For more information on the EPC2034 eGaN FET please refer to the data sheet available from EPC at www.epc-co.com. The data sheet should be read in conjunction with this quick start guide.

QUICK START PROCEDURE

The development boards are easy to set up to evaluate the performance of the eGaN FET. Refer to Figure 2 for proper connect and measurement setup and follow the procedure below:

1. With power off, connect the input power supply bus to +V_{IN} (J5, J6) and ground / return to -V_{IN} (J7, J8).
2. With power off, connect the switch node of the half bridge OUT (J3, J4) to your circuit as required.
3. With power off, connect the gate drive input to +V_{DD} (J1, Pin-1) and ground return to -V_{DD} (J1, Pin-2).
4. With power off, connect the input PWM control signal to PWM (J2, Pin-1) and ground return to any of the remaining J2 pins.
5. Turn on the gate drive supply – make sure the supply is between 7V and 12V range.

Table 1: Performance Summary (T_A = 25°C)

Symbol	Parameter	Conditions	Min	Max	Units
V _{DD}	Gate Drive Input Supply Range		7	12	V
V _{IN}	Bus Input Voltage Range			140	V
V _{OUT}	Switch Node Output Voltage			160	V
I _{OUT}	Switch Node Output Current			12*	A
V _{PWM}	PWM Logic Input Voltage Threshold	Input 'High' Input 'Low'	3.5 0	6 1.5	V V
	Minimum 'High' State Input Pulse Width	V _{PWM} rise and fall time < 10ns	100		ns
	Minimum 'Low' State Input Pulse Width	V _{PWM} rise and fall time < 10ns	100#		ns

*Assumes inductive load, maximum current depends on die temperature – actual maximum current will be subject to switching frequency, bus voltage and thermal management.
Dependent on time needed to 'refresh' high side bootstrap supply voltage.

6. Turn on the controller / PWM input source.
7. Turn on the bus voltage to the required value (do not exceed the absolute maximum voltage of 150 V on V_{OUT}).
8. Once operational, adjust the bus voltage and load PWM control within the operating range and observe the output switching behavior, efficiency and other parameters.
9. For shutdown, please follow steps in reverse.

NOTE. When measuring the high frequency content switch node (OUT), care must be taken to avoid long ground leads. Measure the switch node (OUT) by placing the oscilloscope probe tip through the large via on the switch node (designed for this purpose) and grounding the probe directly across the GND terminals provided. See Figure 3 for proper scope probe technique.

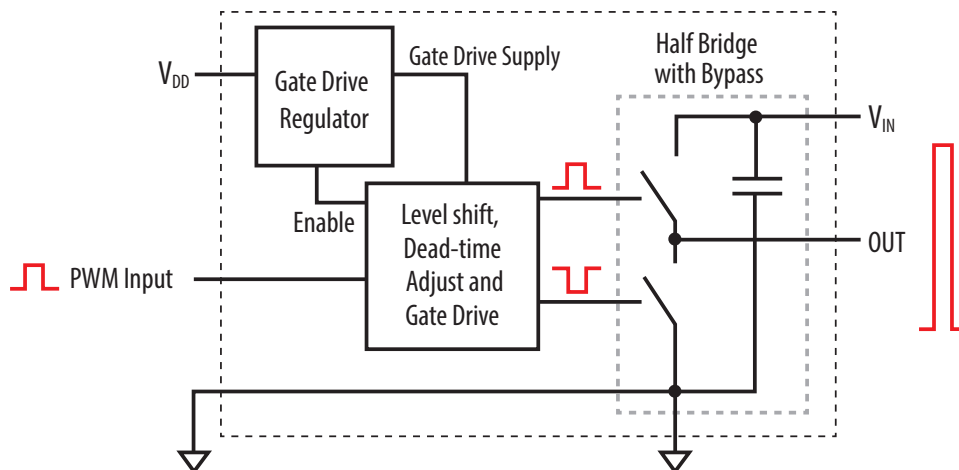

Figure 1: Block Diagram of Development Board

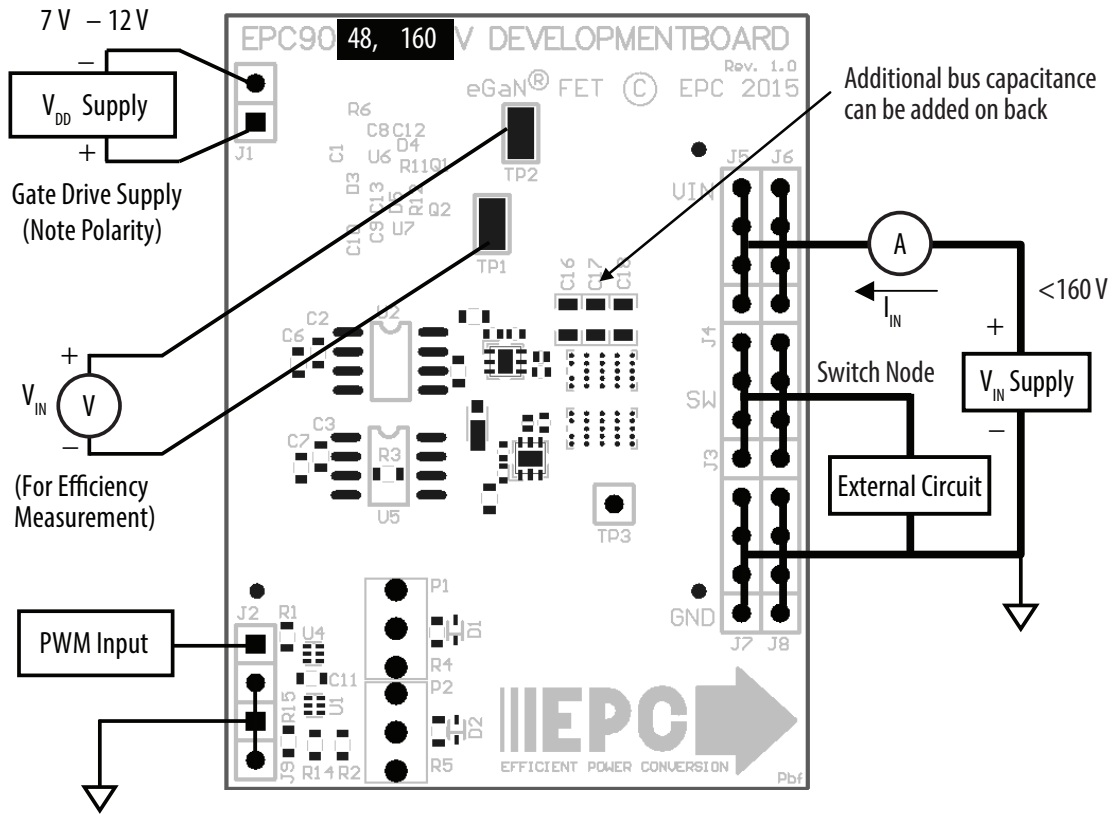

Figure 2: Proper Connection and Measurement Setup

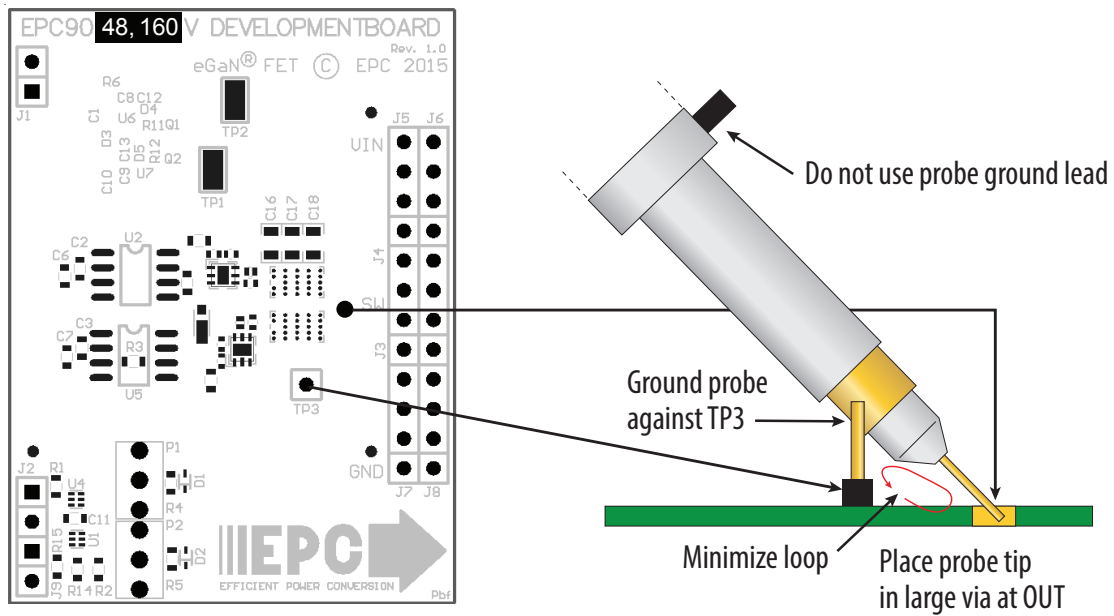

Figure 3: Proper Measurement of Switch Node – OUT

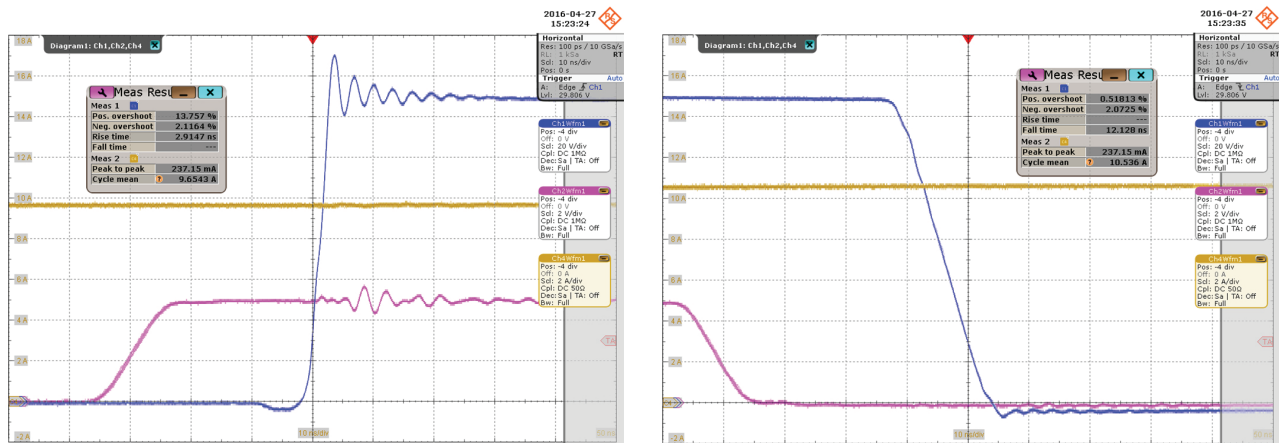

Figure 4: Typical Waveforms for EPC9048. $V_{IN} = 150\text{ V}$ to $7.5\text{ V}/10\text{ A}$ (50 kHz) Buck converter showing rising and falling edges, CH2: (V_{PWM}) Input logic signal – CH4: (I_{OUT}) Output inductor current – CH1: (V_{OUT}) Switch node voltage

THERMAL PERFORMANCE

The EPC9048 development boards showcase the EPC2034 eGaN FETs. These development boards are intended for bench evaluation with low ambient temperature and convection cooling. The addition of heat-sinking and forced air cooling can significantly increase the current rating

of these devices, but care must be taken to not exceed the absolute maximum die temperature of 150°C .

NOTE. The EPC9048 development boards do not have any current or thermal protection on board.

Table 2: Bill of Materials

Item	Qty	Reference	Part Description	Manufacturer / Part #
1	5	C1, C2, C3, C10, C11	Capacitor, 1 μF , 10%, 25 V, X5R	Murata, GRM188R61E105KA12D
2	2	C6, C7	Capacitor, 100 pF, 5%, 50 V, NP0	TDK, C1005X5R1E224K050BC
3	4	C8, C9, C12, C13	Capacitor, 0.22 μF , 10%, 25 V, X5R	TDK, C2012X7T2E104K125AA
4	3	C16, C17, C18	Capacitor, 0.1 μF , 10%, 250 V, X7T	C2012X7T2E104K125AA
5	2	D1, D2	Schottky Diode, 30 V	Diodes Inc., SDM03U40-7
6	1	D3	Diode, 200 V	Diodes Inc., BAV21WS-7-F
7	2	D4, D5	Diode, 40 V	Diodes Inc., BAS40LP-7
8	3	J1, J2, J9	Connector	2 pins of Tyco, 4-103185-0
9	1	J3, J4, J5, J6, J7, J8	Connector	4 pins of FCI, 68602-224HLF
10	2	Q1, Q2	eGaN [®] FET	EPC2034
11	1	R1	Resistor, 10.0 K, 5%, 1/8 W	Stackpole, RMCF0603FT10K0
12	2	R11, R12	Resistor, 1 Ohm, 1%, 1/16 W	Stackpole, RMCF0402FT1R00
13	4	R2, R3, R6, R15	Resistor, 0 Ohm, 1/8 W	Stackpole, RMCF0603ZT00R0
14	1	R4	Resistor, 150 Ohm, 1%, 1/8 W	Stackpole, RMCF0603FT150R
15	1	R5	Resistor, 470 Ohm, 1%, 1/8 W	Stackpole, RMCF0603FT470R
16	2	TP1, TP2	Test Point	Keystone Elect, 5015
17	1	TP3	Connector	1 pin of Tyco, 4-103185-0
18	1	U1	IC, Logic	Fairchild, NC7SZ00L6X
19	1	U2	IC, Opto-coupler	Silicon Labs, Si8610BC
20	1	U4	IC, Logic	Fairchild, NC7SZ08L6X
21	2	U6, U7	IC, Gate driver	Texas Instruments, UCC27611
22	0	P1, P2	Optional potentiometer	
23	0	R14	Optional resistor	
24	0	U5	Optional IC	

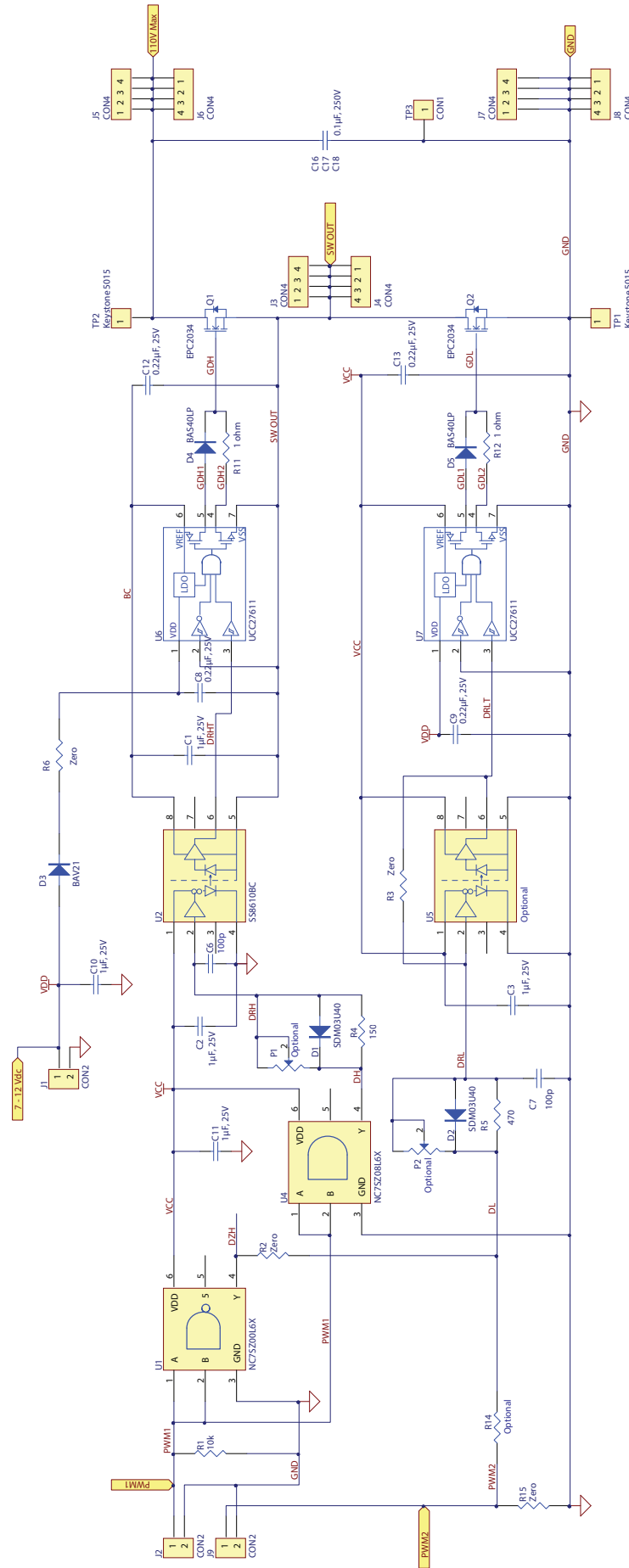

Figure 5: Development Board Schematic

For More Information:

Please contact info@epc-co.com
or your local sales representative

Visit our website:

www.epc-co.com

Sign-up to receive
EPC updates at
bit.ly/EPCupdates
or text "EPC" to 22828



EPC Products are distributed through Digi-Key.

www.digikey.com

Demonstration Board Warning and Disclaimer

The EPC9048 board is intended for product evaluation purposes only and is not intended for commercial use. Replace components on the Evaluation Board only with those parts shown on the parts list (or Bill of Materials) in the Quick Start Guide. Contact an authorized EPC representative with any questions.

This board is intended to be used by certified professionals, in a lab environment, following proper safety procedures. Use at your own risk.

As an evaluation tool, this board is not designed for compliance with the European Union directive on electromagnetic compatibility or any other such directives or regulations. As board builds are at times subject to product availability, it is possible that boards may contain components or assembly materials that are not RoHS compliant. Efficient Power Conversion Corporation (EPC) makes no guarantee that the purchased board is 100% RoHS compliant.

The Evaluation board (or kit) is for demonstration purposes only and neither the Board nor this Quick Start Guide constitute a sales contract or create any kind of warranty, whether express or implied, as to the applications or products involved.

Disclaimer: EPC reserves the right at any time, without notice, to make changes to any products described herein to improve reliability, function, or design. EPC does not assume any liability arising out of the application or use of any product or circuit described herein; neither does it convey any license under its patent rights, or other intellectual property whatsoever, nor the rights of others.