



MAX1234 Evaluation System/Evaluation Kit

General Description

The MAX1234 evaluation system (EV system) consists of a MAX1234 evaluation kit (EV kit) and a Maxim 68HC16MODULE-DIP microcontroller (μ C) module. The MAX1234 is a complete PDA controller with an integrated touch screen and keypad interface. Windows® 95/98/2000 software provides a handy user interface to exercise the MAX1234's features.

Order the complete EV system (MAX1234EVC16) for comprehensive evaluation of the MAX1234 using a personal computer. Order the EV kit (MAX1234EVKIT) if the 68HC16MODULE-DIP module has already been purchased with a previous Maxim EV system or for custom use in other μ C-based systems.

MAX1234 Stand-Alone EV Kit

The MAX1234 EV kit provides a proven PC board layout to facilitate evaluation of the MAX1234. It must be interfaced to appropriate timing signals for proper operation. Connect 5V and ground return to terminal block TB1 (see Figure 8). Refer to the MAX1234 data sheet for timing requirements.

MAX1234 EV System

The MAX1234 EV system operates from a user-supplied 7VDC to 20VDC power supply. Windows 95/98/2000 software running on an IBM PC interfaces to the EV system board through the computer's serial communications port. See the *Quick Start* section for setup and operating instructions.

Ordering Information

The MAX1234 software is designed for use with the complete EV system MAX1234EVC16, which includes the 68HC16MODULE-DIP module together with MAX1234 EVKIT. If the MAX1234 EV software is not used, the MAX1234EVKIT board can be purchased by itself, without the μ C module.

Ordering Information

PART	TEMP RANGE	INTERFACE TYPE
MAX1234EVKIT	0°C to +70°C	User supplied
MAX1234EVC16	0°C to +70°C	Windows software

Windows is a registered trademark of Microsoft Corp.

Features

- ◆ Proven PC Board Layout
- ◆ Complete Evaluation System
- ◆ Convenient Test Points Provided On Board
- ◆ Fully Assembled and Tested
- ◆ 4 × 4 Keypad Included
- ◆ Interfaces to Common 4-Wire Resistive Touch Screens

Component Lists

Table 1. MAX1234 EV System

PART	QTY	DESCRIPTION
MAX1234EVKIT	1	MAX1234 EV kit
68HC16MODULE-DIP	1	68HC16 μ C module

Table 2. MAX1234 EV Kit

DESIGNATION	QTY	DESCRIPTION
C1, C2	2	10 μ F, 10V tantalum capacitors
C3, C4	2	0.1 μ F, 10V X7R ceramic capacitors
C5	1	Open
FB1	1	Ferrite bead
H1, H2, H3, H4	4	7-pin headers
H5	1	0.100in header, 2 × 10
H6	1	0.5mm ZIP SMT flex cable connector Digi-Key HKF20CT-ND Hirose FH12A-20S-0.5SH
J1	1	2 × 20 right-angle socket SamTec SSW-120-02-S-D-RA
JU1	1	3-pin jumper
K1	8	Socket pins for 4 × 4 keypad Digi-Key ED5009 pin receptacles
K1	1	4 × 4 keypad, Grayhill Series 96, front mount Digi-Key GH5003-ND Digi-Key GH5004-ND
U1	1	MAX1234EGT (28-pin QFN)
U2	1	MAX1615EUK
U3, U4, U5	3	MAX1840EUB or MAX1841EUB
TB1	1	0.200in screw terminal block
None	1	PC board
None	1	3.5in software disk
None	1	MAX1234 data sheet
None	1	MAX1234 EV kit data sheet
None	1	68HC16MODULE-DIP data sheet

Evaluates: MAX1233/MAX1234



MAX1234 Evaluation System/Evaluation Kit

Quick Start

Before you begin, the following equipment is needed:

- MAX1234EVC16 (contains MAX1234 EV kit board and 68HC16MODULE-DIP)
- A small DC power supply, such as a 12VDC 0.25A plug-in transformer, or a 9V battery
- An IBM PC-compatible computer running Windows 95/98/2000
- A spare serial communications port, preferably a 9-pin plug
- A serial cable to connect the computer's serial port to the 68HC16MODULE-DIP
- Standard 4-wire resistive touch screen.

Do not turn on the power until all connections are made:

- 1) Ensure that the MAX1234 EV kit's JU1 jumper has a shunt installed in the MAX1234 position.
- 2) Carefully connect the boards by aligning the 40-pin header of the MAX1234 EV kit with the 40-pin connector of the 68HC16MODULE-DIP module. Gently press them together. The two boards should be flush against one another.
- 3) Connect a 7VDC to 20VDC power source to the μ C module at the terminal block located next to the on/off switch, along the top edge of the μ C module. Observe the polarity marked on the board.
- 4) Connect a cable from the computer's serial port to the μ C module. If using a 9-pin serial port, use a straight-through, 9-pin, female-to-male cable. If the only available serial port uses a 25-pin connector, a standard 25-pin to 9-pin adapter is required. The EV kit software checks the modem status lines (CTS, DSR, DCD) to confirm that the correct port has been selected.
- 5) Install the EV software on your computer by running the INSTALL.EXE program on the floppy disk. The program files are copied and icons are created for them in the Windows Start menu.
- 6) Turn on the power supply.
- 7) Start the MAX1234 program by opening its icon in the Start menu.
- 8) At the prompt, connect the μ C module and turn on its power. Slide SW1 to the ON position. Select the correct serial port, and click **OK**. The program automatically downloads its software to the module.
- 9) Connect the 4-wire resistive touch screen to the X+, Y+, X-, and Y- pins of the header. For convenience, a 20-pin 0.5mm flex cable breakout is provided by headers H5 and H6.
- 10) Click **Demo Touchscreen**. The software tracks the motion of a stylus on the touch screen (see Figure 1).
- 11) Click **Demo Keypad**. The software tracks key presses (see Figure 5).

Detailed Description of Software

The EV software's main window configures the interrupt handler and displays the internal registers in binary.

To aid development of custom interrupt-driven software, the **Interrupt Handler** tab (see Figure 1) handles interrupt request (IRQ) response. Both **PENIRQ** and **KEYIRQ** can be polled, and a set of checkboxes select the desired response.

The low-level registers are grouped by function. The **ADC regs** tab (see Figure 2) controls the analog-to-digital converter, including the touch-screen digitizer. The **DAC regs** tab controls the digital-to-analog output. The **KEY regs** tab is for the keypad, and the **GPIO regs** tab is for the general-purpose input/output (GPIO) pins. Each register can be read or written by clicking the corresponding **Read** or **Write** button. (Registers that cannot be written do not have a write button.)

The **ADC**, **DAC**, **KEY**, and **GPIO** buttons open an application-oriented view of their respective functions. Interrupt response is also handled by the main screen.

Analog-to-Digital Converter Window

The MAX1234: Analog to Digital Converter window controls the touch-screen digitizer, the auxiliary voltage inputs, the temperature measurement, and the reference voltage. By default, the software automatically waits for BUSY and then reads updated data after writing to the ADC control register (see Figure 3).

For improved accuracy, measure the reference voltage and enter its value into **Actual REF Voltage**. This only affects the BAT1, BAT2, AUX1, AUX2, and temperature voltage reporting. The MAX1234 code outputs are not affected. When the REFV control bit is changed, the software automatically resets the **Actual REF Voltage** to 1.0V or 2.5V, unless **Ask before changing REF** is checked.

The temperature measurement can be further calibrated by adjusting **Room Temperature centigrade** and **"TEMP1 Vroom"** for TEMP1 measurements, or by adjusting **"Temp2-Temp1 K/delta V"** for Temp2-Temp1 measurements. Refer to the MAX1234 data sheet for more information on temperature measurement.

MAX1234 Evaluation System/Evaluation Kit

Evaluates: MAX1233/MAX1234

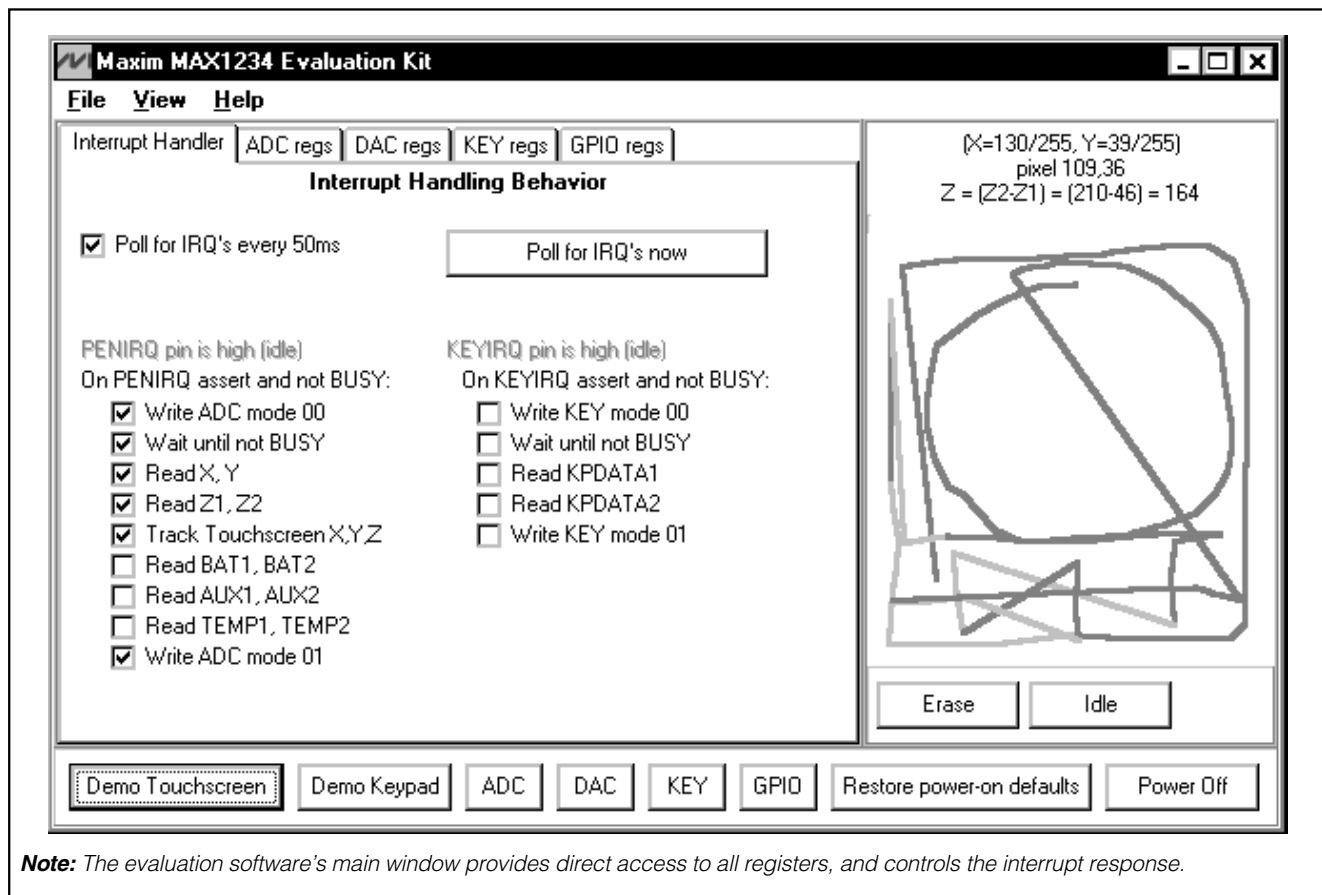

Note: The evaluation software's main window provides direct access to all registers, and controls the interrupt response.

Figure 1. EV Software's Main Window

Digital-to-Analog Converter Window

The MAX1234: Digital to Analog Converter window controls the voltage at the DACOUT pin. Enter the DAC code value between 0 and 255, and click **Write DAC**. The DAC can be powered off by clicking **DAC Off** (see Figure 4).

For improved accuracy, set the DAC output code to 255 and measure the actual DACOUT voltage. Enter the full-scale voltage into **DAC Full-Scale Voltage** to adjust the reported ideal DAC output voltage.

Keypad Window

The Keypad window controls the 4 × 4 keypad scanner. Use the drop-down combo boxes to set up the keypad control register, then click **Write KEY Control**. Refer to the MAX1234 data sheet for suggested usage details (see Figure 5).

Click **Read KPDATA1** to read data masked by the column mask. Click **Read KPDATA2** to read keypad data masked by the key mask and column mask. Active key presses are highlighted on the keypad display.

Mask individual keys using the appropriate **R1C1...R4C4** checkboxes and clicking **Write key mask**. Or mask an entire column using the **C1–C4** checkboxes and clicking **Write column mask**. Masked keys are grayed on the keypad display.

GPIO Window

The GPIO screen reassigns the keypad pins to general-purpose input and output. Keypad pins R1–R4 and C1–C4 can be individually assigned to GPIO. The **Write GPIO** button writes all of the GPIO registers from the checkboxes. Each GPIO pin can be configured as an input, a totem-pole output, or an open-collector output (see Figure 6).

MAX1234 Evaluation System/Evaluation Kit

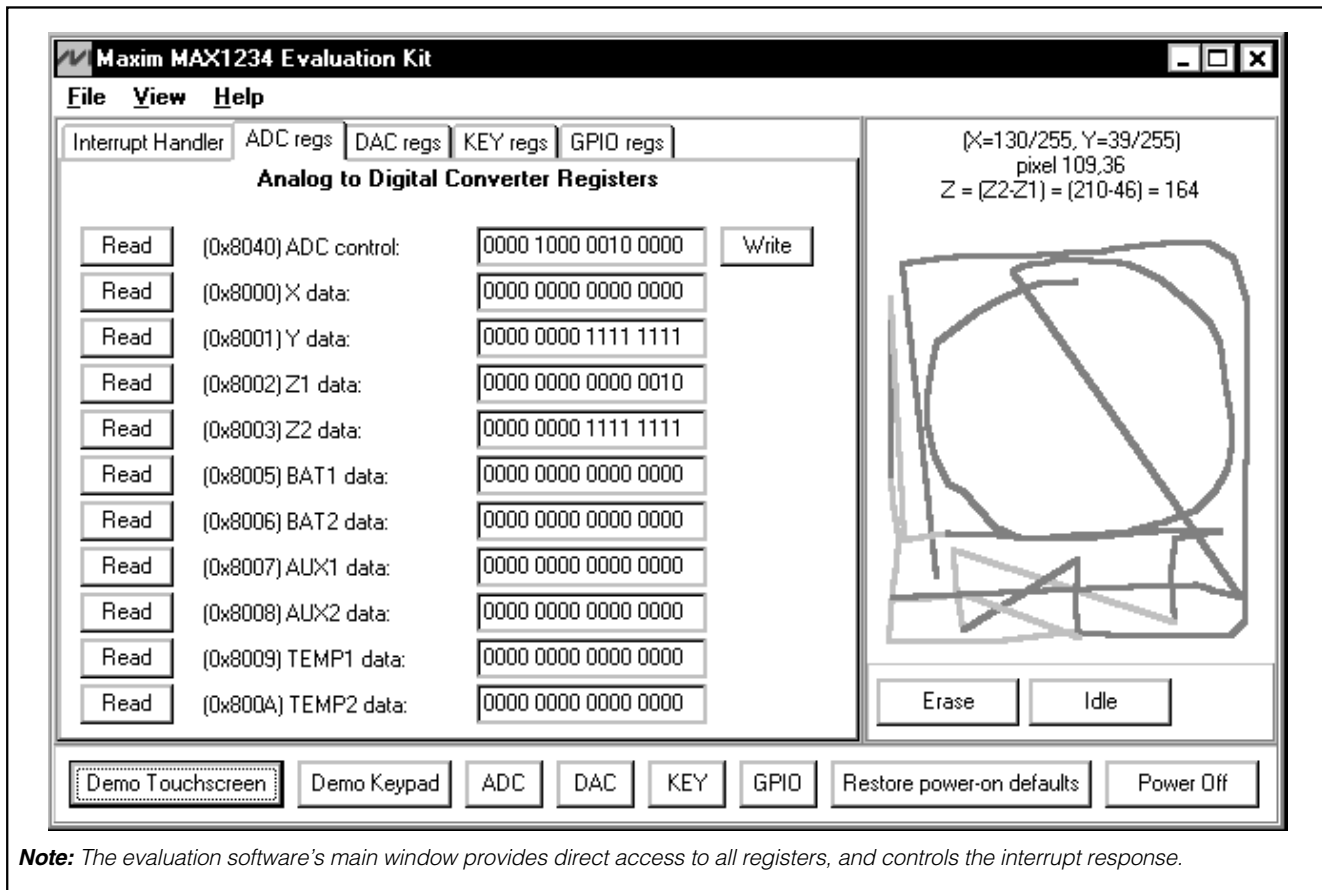

Figure 2. EV Software's Main Window

Diagnostics Window

The Diagnostics screen performs a battery of tests on the system. From the main window's **View** menu, activate **Diagnostics**. To select individual tests, change the mode from **EV Kit Production Test** to **Diagnostics**. Scroll to the desired test, check the appropriate boxes, and click its **Test** button (see Figure 7).

The **Download** test downloads the operating code to the μ C module, if it is not already running. The **Initialize** test verifies power-on defaults values of the MAX1234 registers. The **Readback** test verifies the DIN, DOUT, SCLK, and CS pins of the serial interface by writing test patterns to the registers, and then reading back those test patterns. The **Keypad** test checks the KEYIRQ interrupt pin, the R1-R4 and C1-C4 pins, and the keypad controller. The **DAC analog output test** uses the AUX2 pin to measure the DAC analog output. (**Note:** AUX2 should be tied to DAC when performing this test.) The **ADC analog**

inputs test measures the ADC analog inputs BAT1, BAT2, AUX1, and AUX2. The **ADC touch-screen inputs test** checks the $\overline{\text{PENIRQ}}$ interrupt pin, the BUSY pin, the X+/X- and Y+/Y- drivers, and the analog inputs.

Detailed Description of Hardware

The MAX1234 device under test (U1) requires no support components except the supply bypass capacitors (C1, C2). The 4 x 4 keypad (K1) interfaces directly to U1. Other styles of keypad can be evaluated by unplugging K1 and installing a user-supplied keypad. Commonly available touch screens using 20-pin 0.5mm flex ribbon cable can be plugged into H6 and then wired from H5 to the X+, X-, Y+, and Y- pins on the breakout header. See Figure 8, the *MAX1234 EV Kit Schematic*, and refer to the MAX1234 data sheet.

MAX1234 Evaluation System/Evaluation Kit

Evaluates: MAX1233/MAX1234

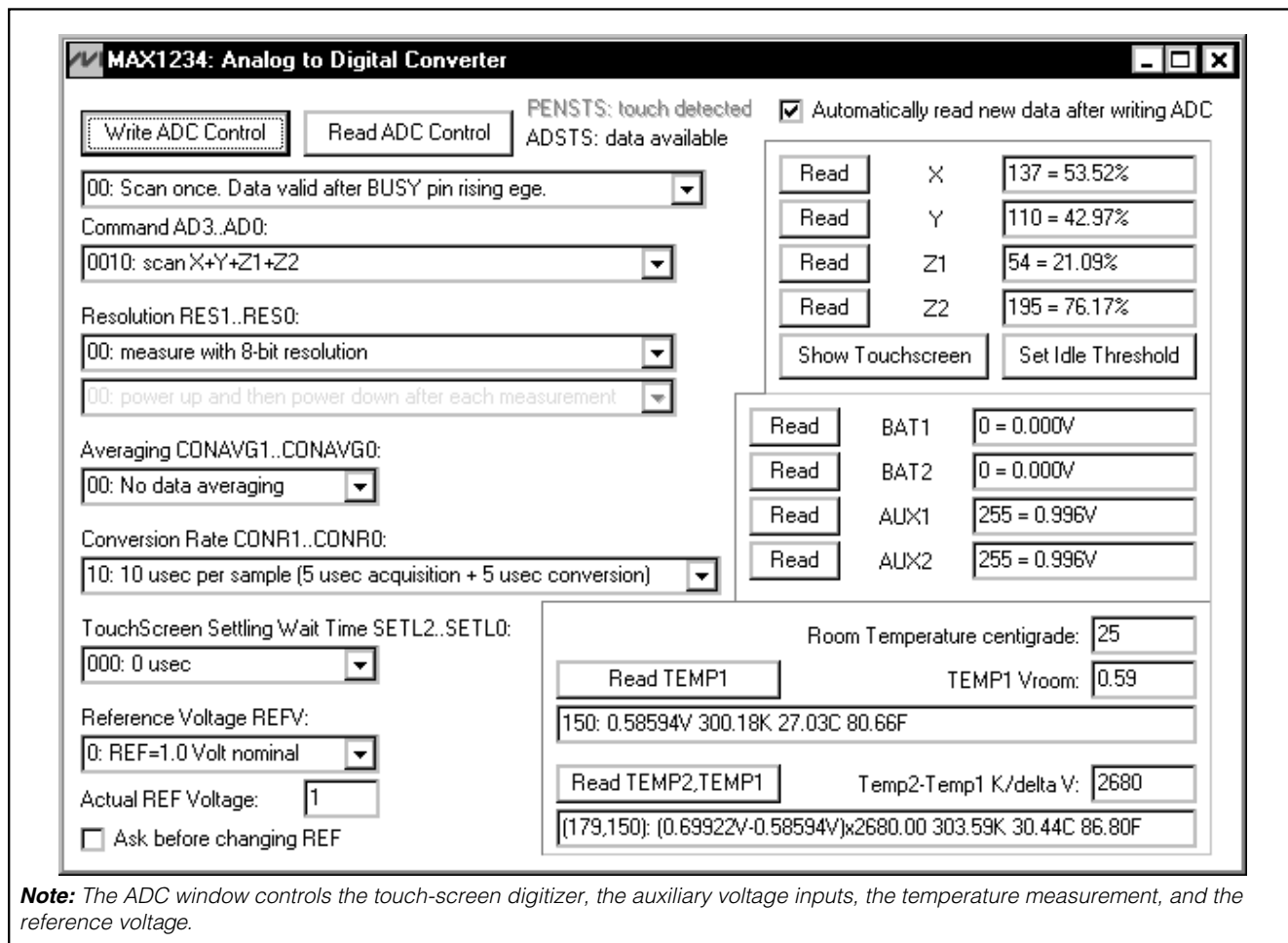

Figure 3. Analog-to-Digital Converter Window

The EV kit includes a MAX1615 3V/5V linear regulator and a set of MAX1840/MAX1841 level shifters to support using the 3V MAX1233 with the 5V μ C.

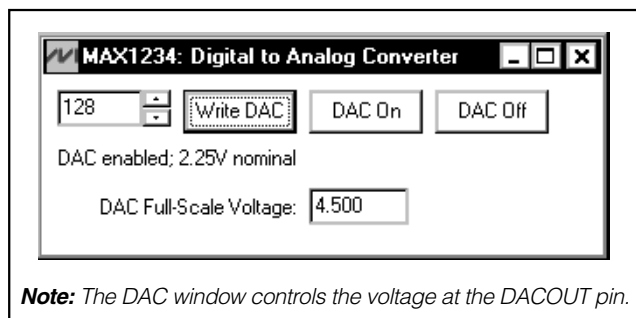

Figure 4. Digital-to-Analog Converter Window

Touch-Screen Equivalent Circuit

For prototyping purposes, a 4-wire resistive touch screen can be simulated using two variable resistors connected by a resistor and a switch. Variable resistor X, connected between X+ and X-, should be approximately 100 Ω to 500 Ω . Variable resistor Y, connected between Y+ and Y-, should be approximately 100 Ω to 500 Ω . Connect the center wipers of the two variable resistors using a fixed resistor of approximately 300 Ω , simulating the touch resistance. See Figure 9.

Evaluating the MAX1233

The MAX1233 is the 3V version of the MAX1234. Request a free sample of MAX1233EGT. Using the MAX1233, replace U1, and move the JU1 shunt to the MAX1233 position. In the software's DAC window, change **DAC Full-Scale Voltage** to 2.97V (90% of 3.3V).

MAX1234 Evaluation System/Evaluation Kit

Evaluates: MAX1233/MAX1234

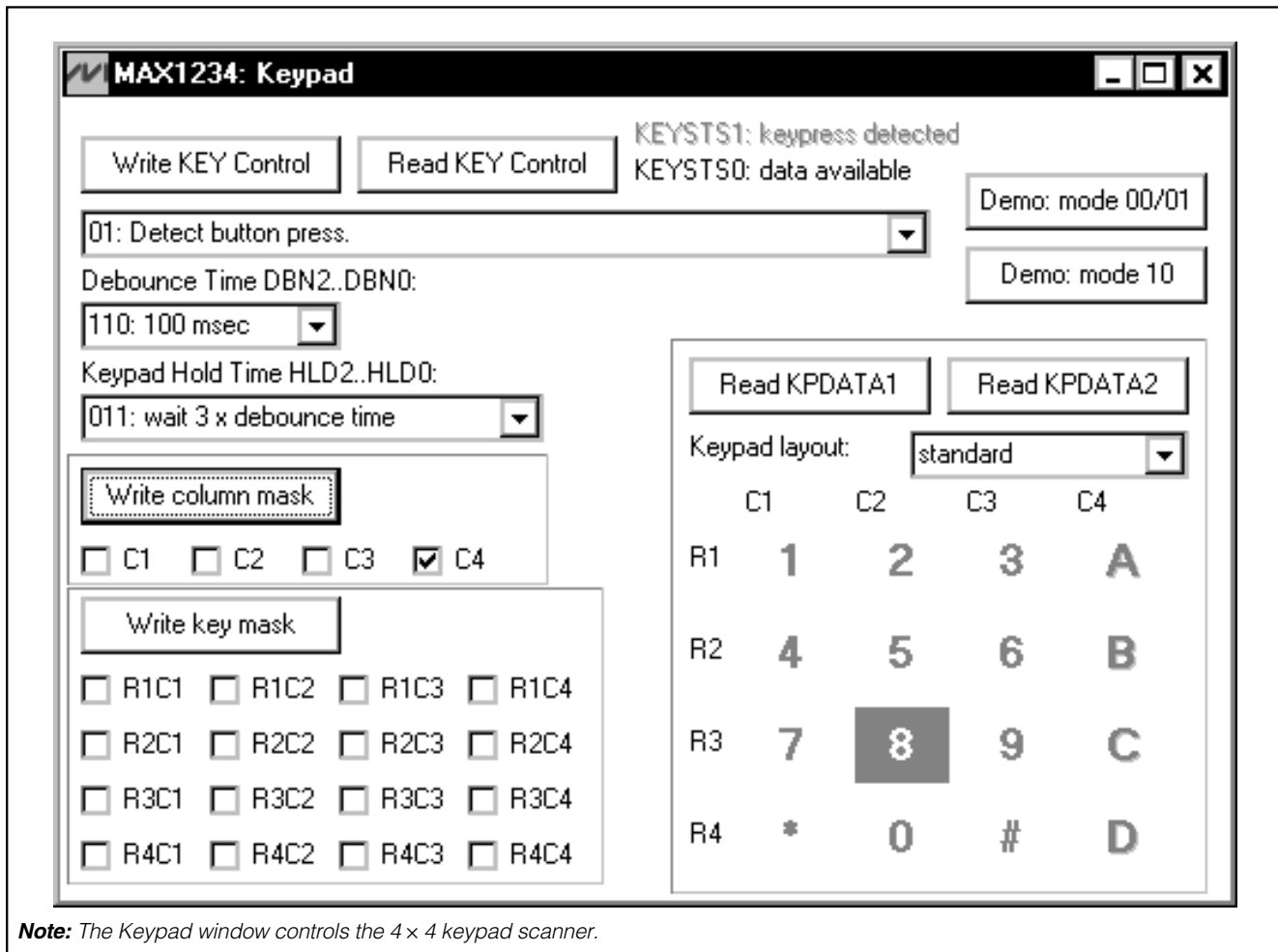

Figure 5. Keypad Window

Troubleshooting

Problem: No output measurement. System seems to report zero voltage, or fails to make a measurement.

Check VDD and VLOGIC supply voltages. Configure the ADC power-up settings to "always on" by writing binary code 00-0000-01-xx-xx-xxx-x to the **ADC Control Register** (see Figure 2). Then check the reference voltage using a digital voltmeter. Use an oscilloscope to verify that the **BUSY** pin is strobed low, indicating that a measurement is performed.

Problem: Measurements are erratic, unstable; poor accuracy.

Check the reference voltage using a digital voltmeter. Use an oscilloscope to check for noise. When probing for noise, keep the oscilloscope ground return lead as short as possible, preferably less than 1/2in (10mm). Try increasing the acquisition time or settling time. Try forcing measurements using ADC or KEY mode 00. Try connecting a good quality 0.1µF ceramic capacitor between the affected input and ground.

MAX1234 Evaluation System/Evaluation Kit

Evaluates: MAX1233/MAX1234

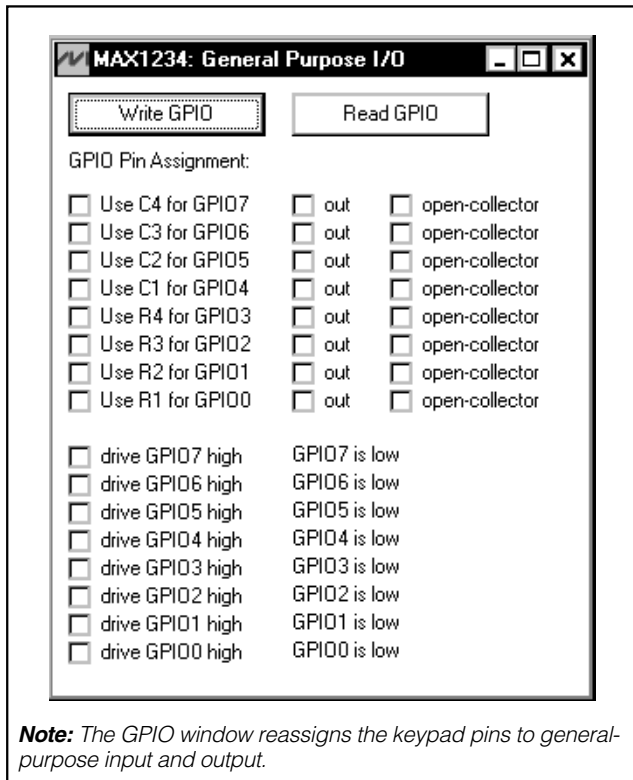

Figure 6. GPIO Window

MAX1234 Evaluation System/Evaluation Kit

Evaluates: MAX1233/MAX1234

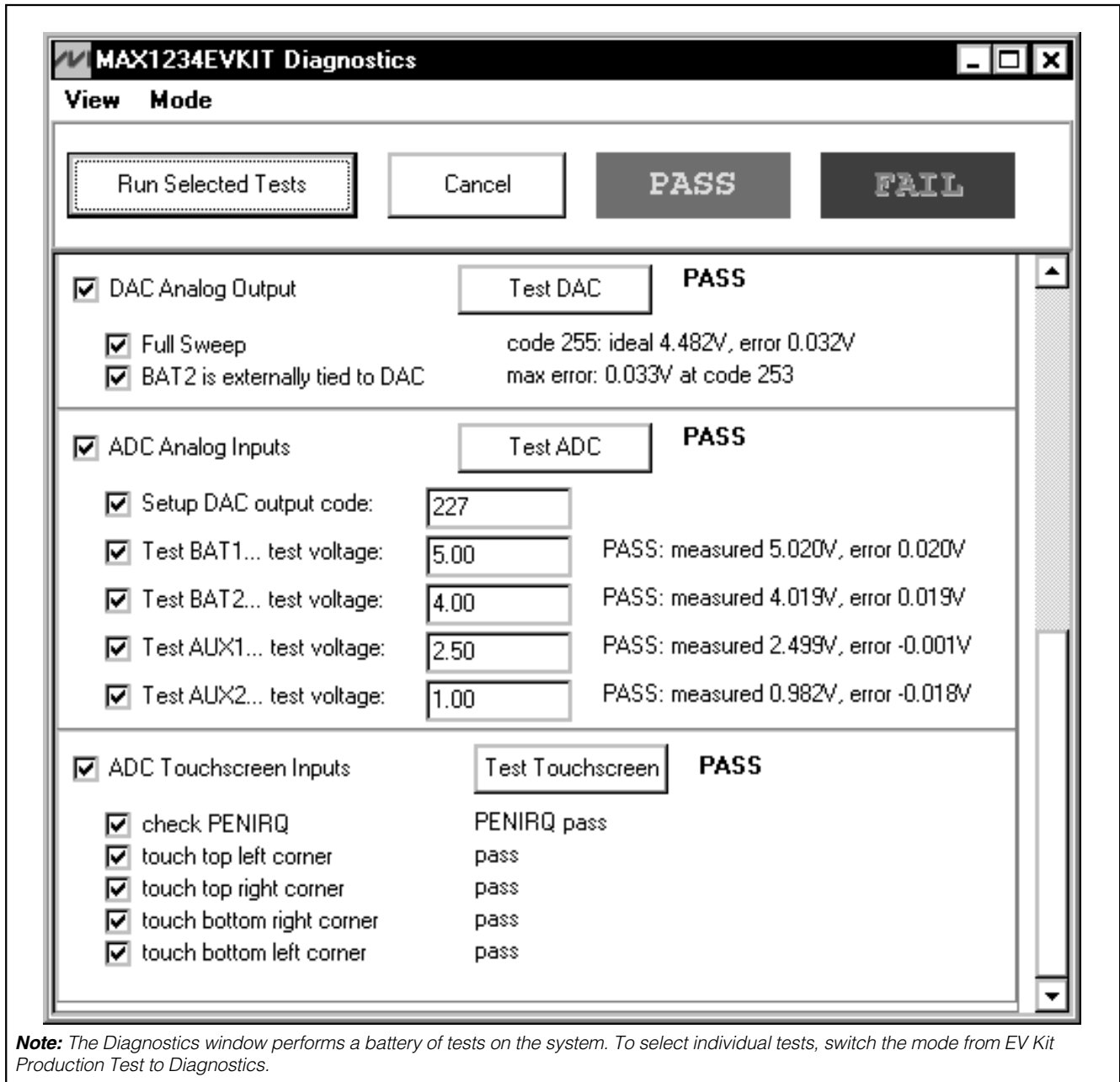

Figure 7. Diagnostics Window

MAX1234 Evaluation System/Evaluation Kit

Evaluates: MAX1233/MAX1234

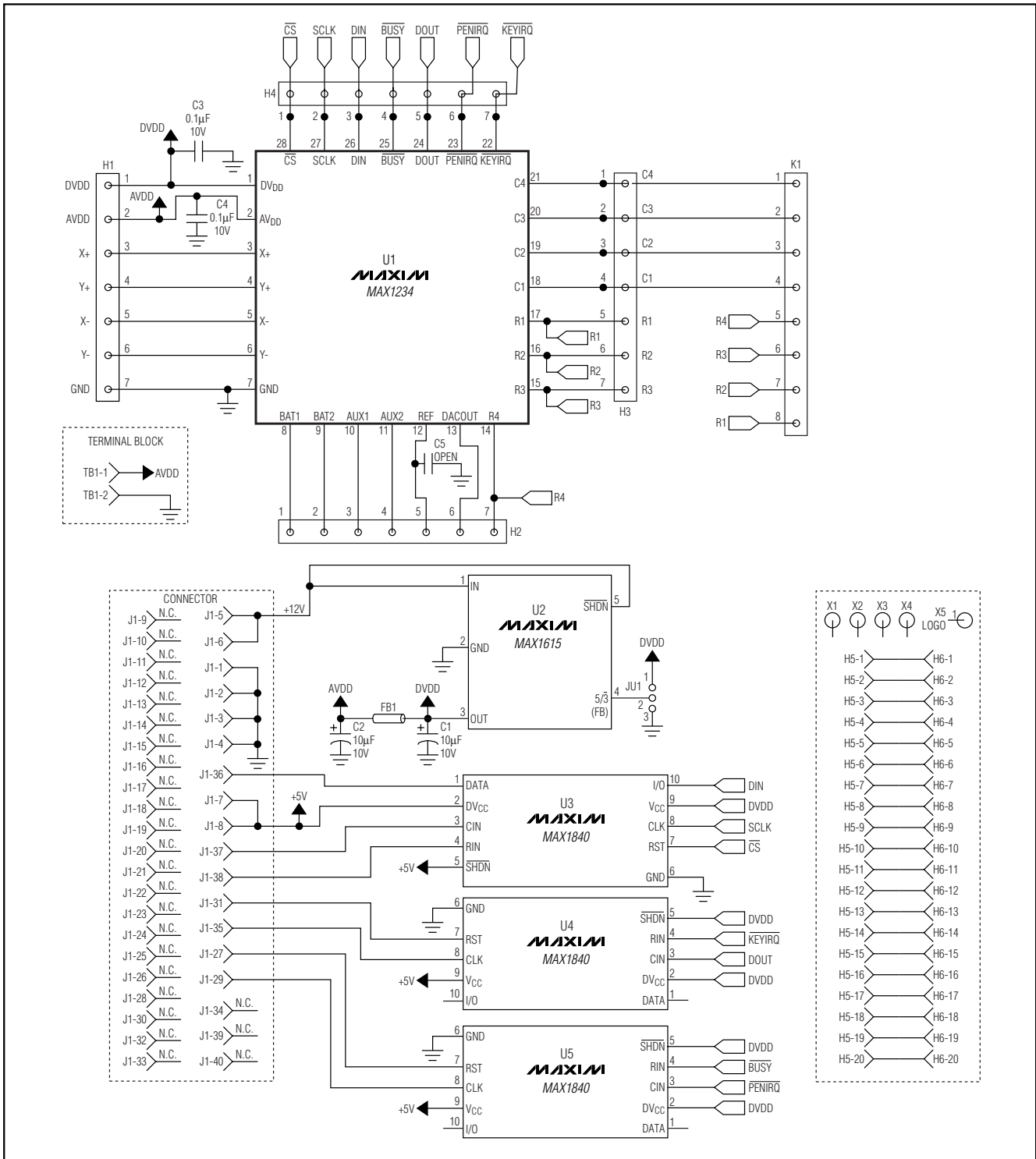

Figure 8. MAX1234 EV Kit Schematic

MAX1234 Evaluation System/Evaluation Kit

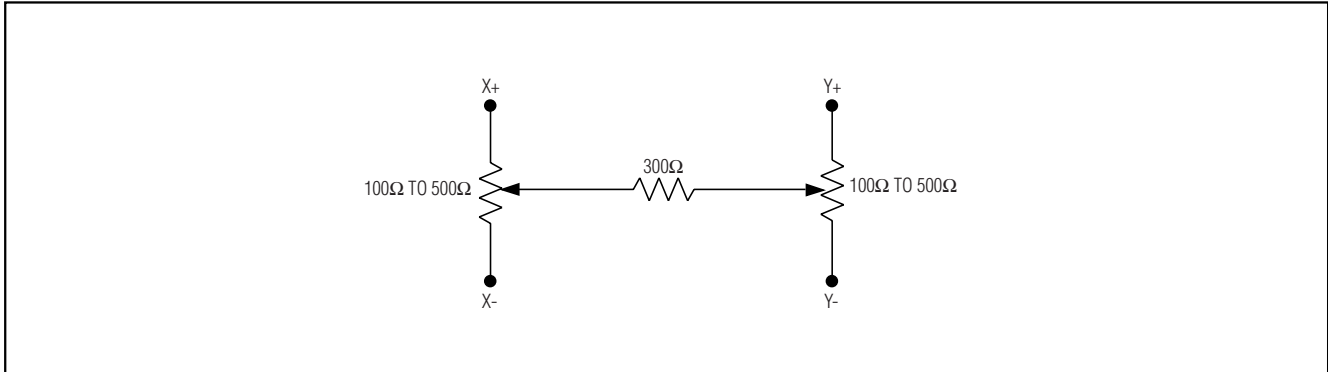

Figure 9. Touch-Screen Equivalent Circuit

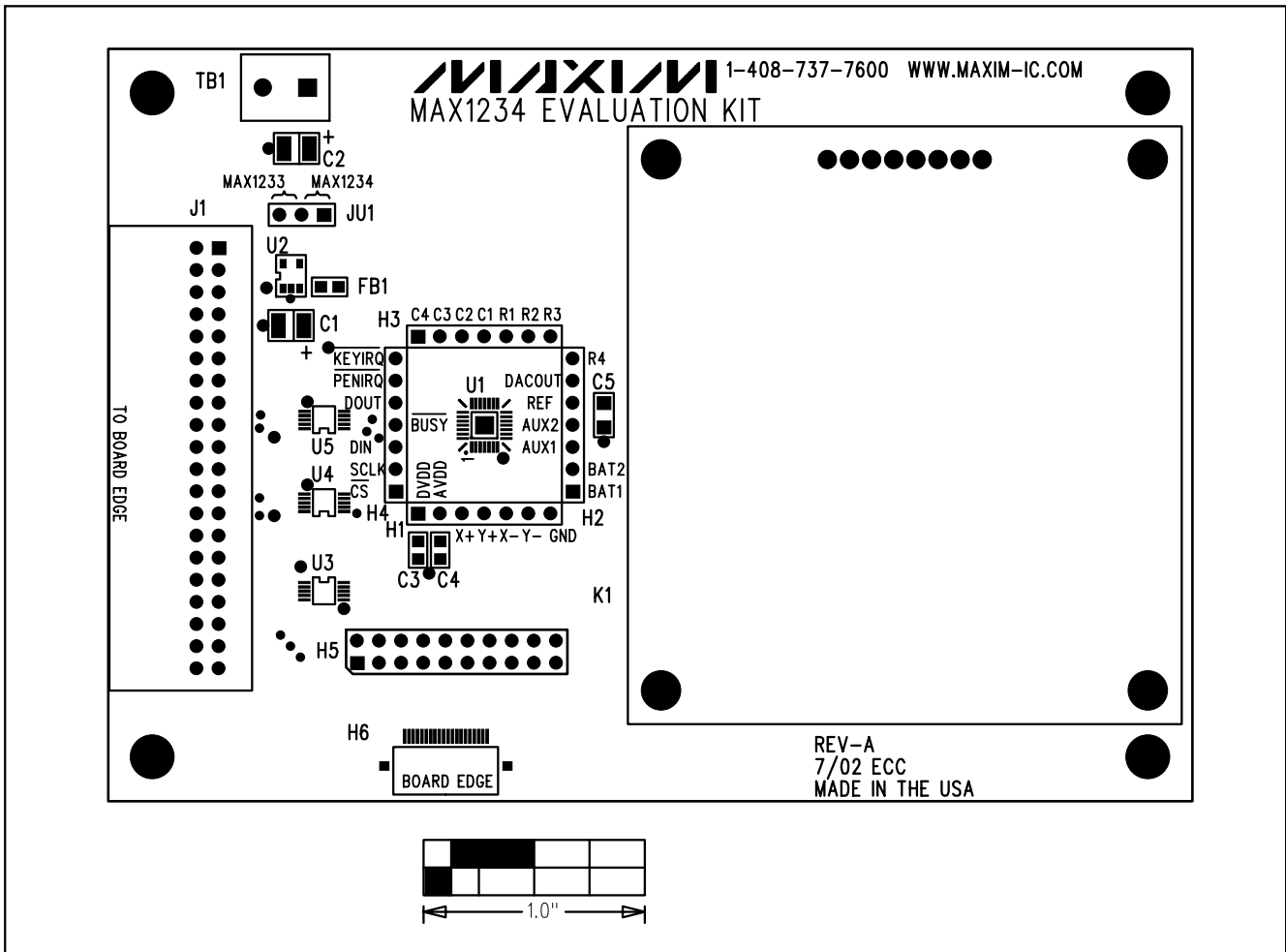

Figure 10. MAX1234 EV Kit Component Placement Guide—Component Side

MAX1234 Evaluation System/Evaluation Kit

Evaluates: MAX1233/MAX1234

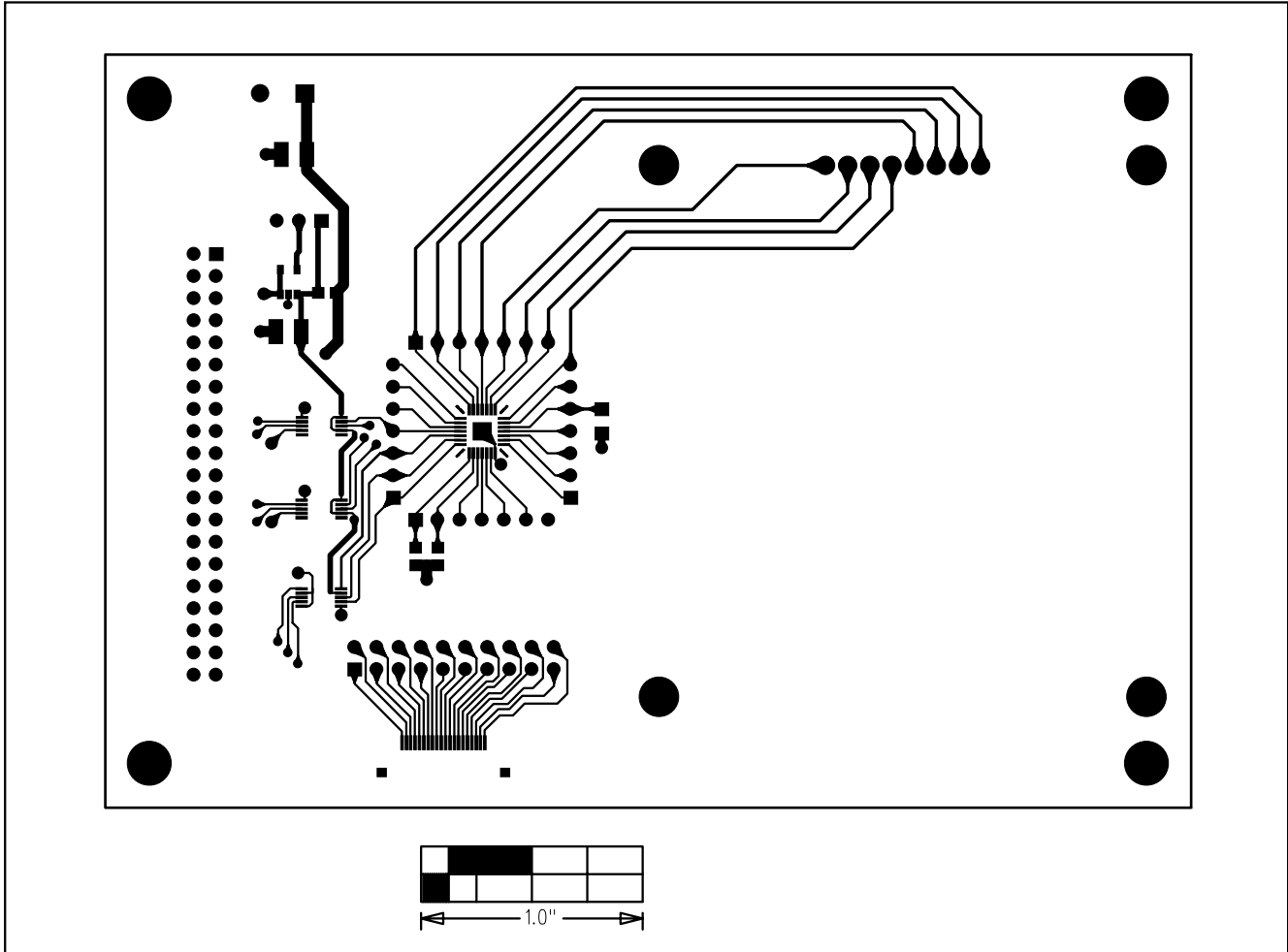

Figure 11. MAX1234 EV Kit PC Board Layout—Component Side

MAX1234 Evaluation System/Evaluation Kit

Evaluates: MAX1233/MAX1234

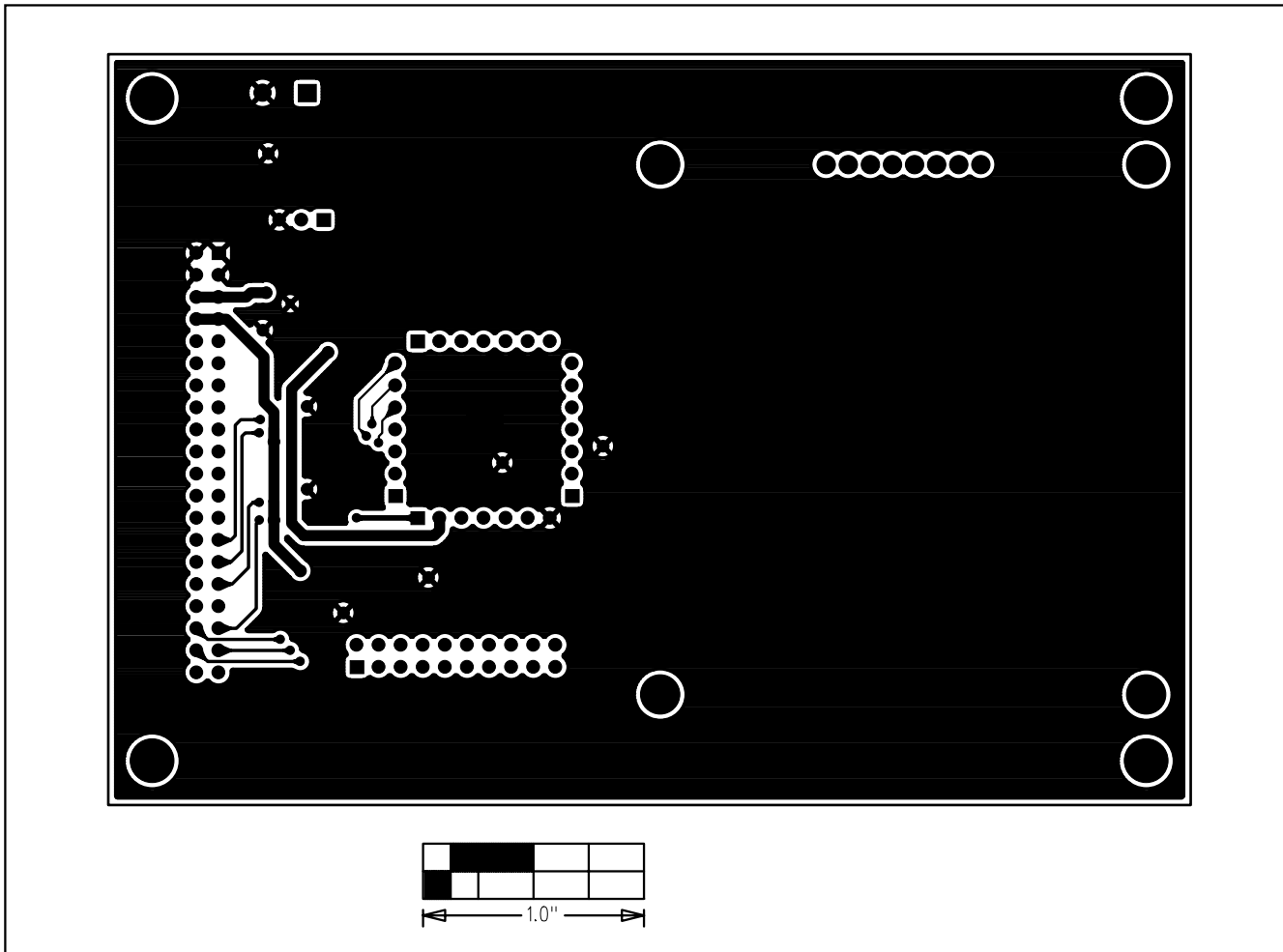

Figure 12. MAX1234 EV Kit PC Board Layout—Solder Side

Maxim cannot assume responsibility for use of any circuitry other than circuitry entirely embodied in a Maxim product. No circuit patent licenses are implied. Maxim reserves the right to change the circuitry and specifications without notice at any time.

12 _____ **Maxim Integrated Products, 120 San Gabriel Drive, Sunnyvale, CA 94086 408-737-7600**