

EMBOSSED TAPE PART NO	REEL PART NO	TOP TAPE PART NO	ASSEMBLY PART NO	QUANTITY/ REEL	REELS/ CARTON
78888-2117	89990-5772	89990-5607	78715-0004	250	4 REELS/ CARTON
			78715-0005		
			78715-0007		
			78715-0011		
			78715-0013		
			78715-0026		
			78715-0025		

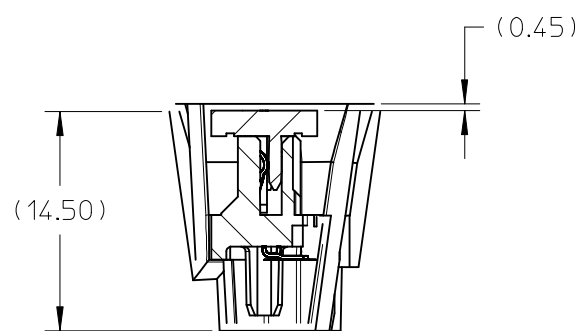

SECTION Z-Z

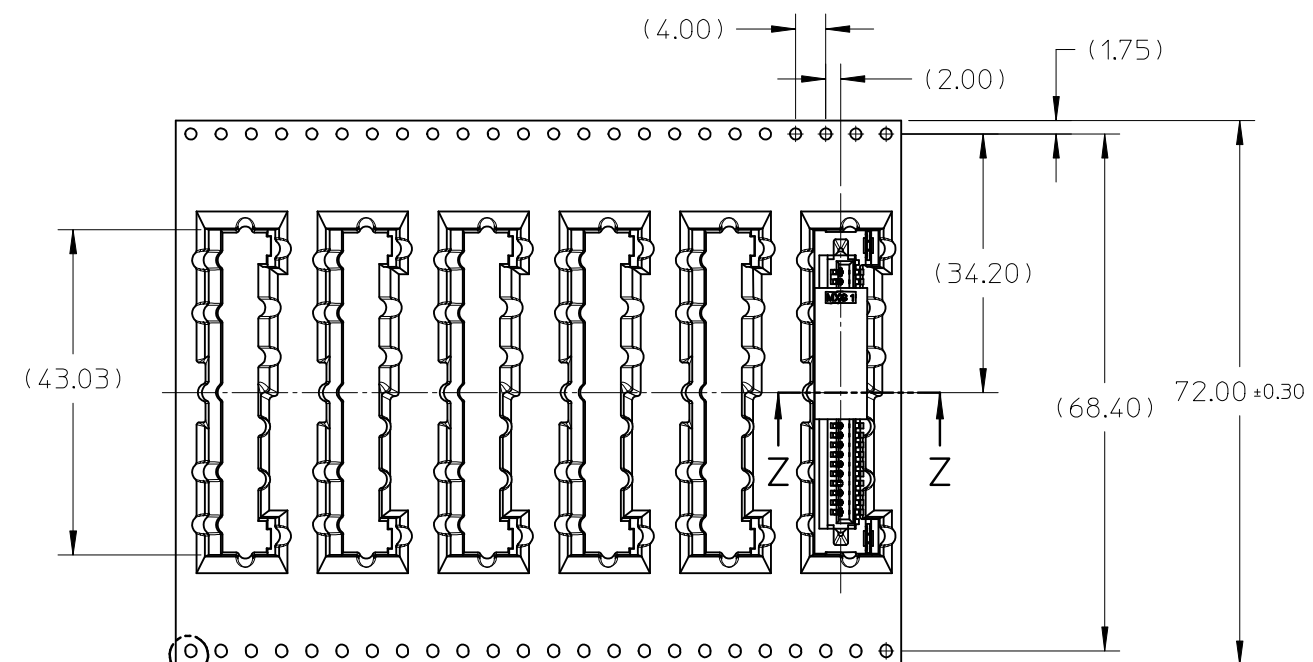

DETAIL1

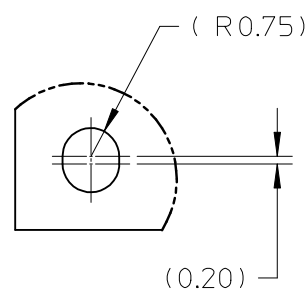

DETAIL1

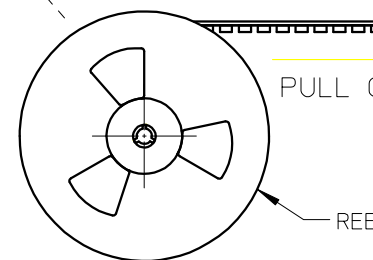

NOTES:

1. LEADER AND TRAILER TAPE

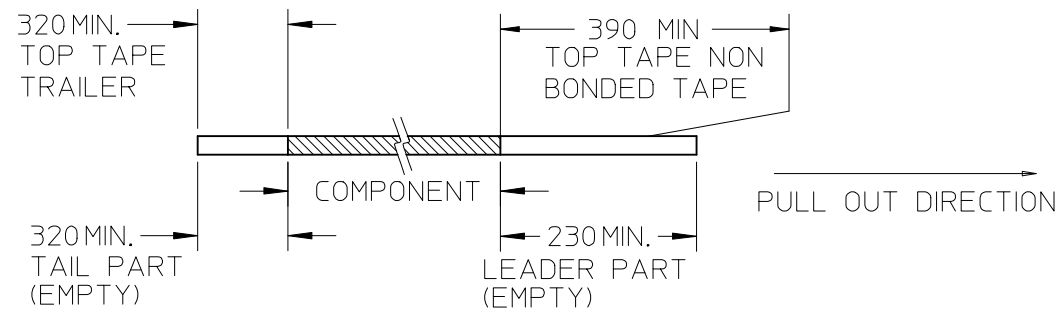

2. PEELING OFF FORCE OF THE TOP TAPE: 20 - 80gf.  
(PEELING DIRECTION AS SHOWN IN FOLLOWING FIGURE)

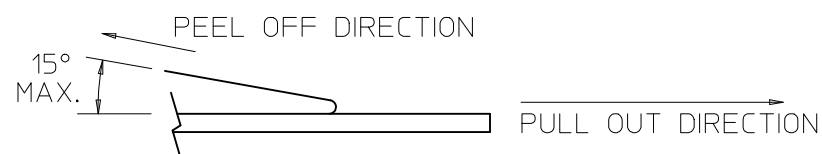

- 3. TAPE AND REEL SPECIFICATION IS AS PER EIA-481.
- 4. TAPE AND REEL QUANTITY : 250 PCS/ REEL.
- 5. THE TAPE IS TREATED FOR ANTI-STATIC.
- 6. PARTS TO BE PACKED AND ORIENTATED AS PER DETAIL SHOWN.
- 7. CLOSE CARTON WITH TAPE.
- 8. ORIENTATION OF THE CONNECTOR IN ALL OTHER PRODUCTS ARE SAME AS THE SHOWN.

ADD P/N 78715-0025 EC NO: S2015-0542 DRWN:HCGOH 2014/12/04 CH'KD:JESSIECHUA 2014/12/04 APPR:SHONG 2015/01/05	QUALITY SYMBOLS $\nabla_A = 0$ $\nabla_C = 0$ $\nabla_F = 0$	GENERAL TOLERANCES (UNLESS SPECIFIED)		DIMENSION STYLE	SCALE	DESIGN UNITS			
				MM ONLY	NTS	METRIC			
				mm	INCH	DRAWN BY	DATE	TITLE	<b>PACKAGING SPECIFICATION FOR 78715 (TAPE &amp; REEL) SAS RECEPTACLES</b>
				4 PLACES ± ---	± ---	CGOH	2011/10/11		
		3 PLACES ± ---	± ---	CHECKED BY	DATE	DOCUMENT NO.	SHEET NO.		
		2 PLACES ± ---	± ---	SCHEONG	2011/10/20	PK-78715-003	1 OF 2		
		1 PLACE ± ---	± ---	APPROVED BY	DATE				
		0 PLACE ±	±	BOKOK	2011/10/20	THIS DRAWING CONTAINS INFORMATION THAT IS PROPRIETARY TO MOLEX INCORPORATED AND SHOULD NOT BE USED WITHOUT WRITTEN PERMISSION			
		ANGULAR ± --- °		MATERIAL NO.					
		DRAFT WHERE APPLICABLE MUST REMAIN WITHIN DIMENSIONS		SEE TABLE					

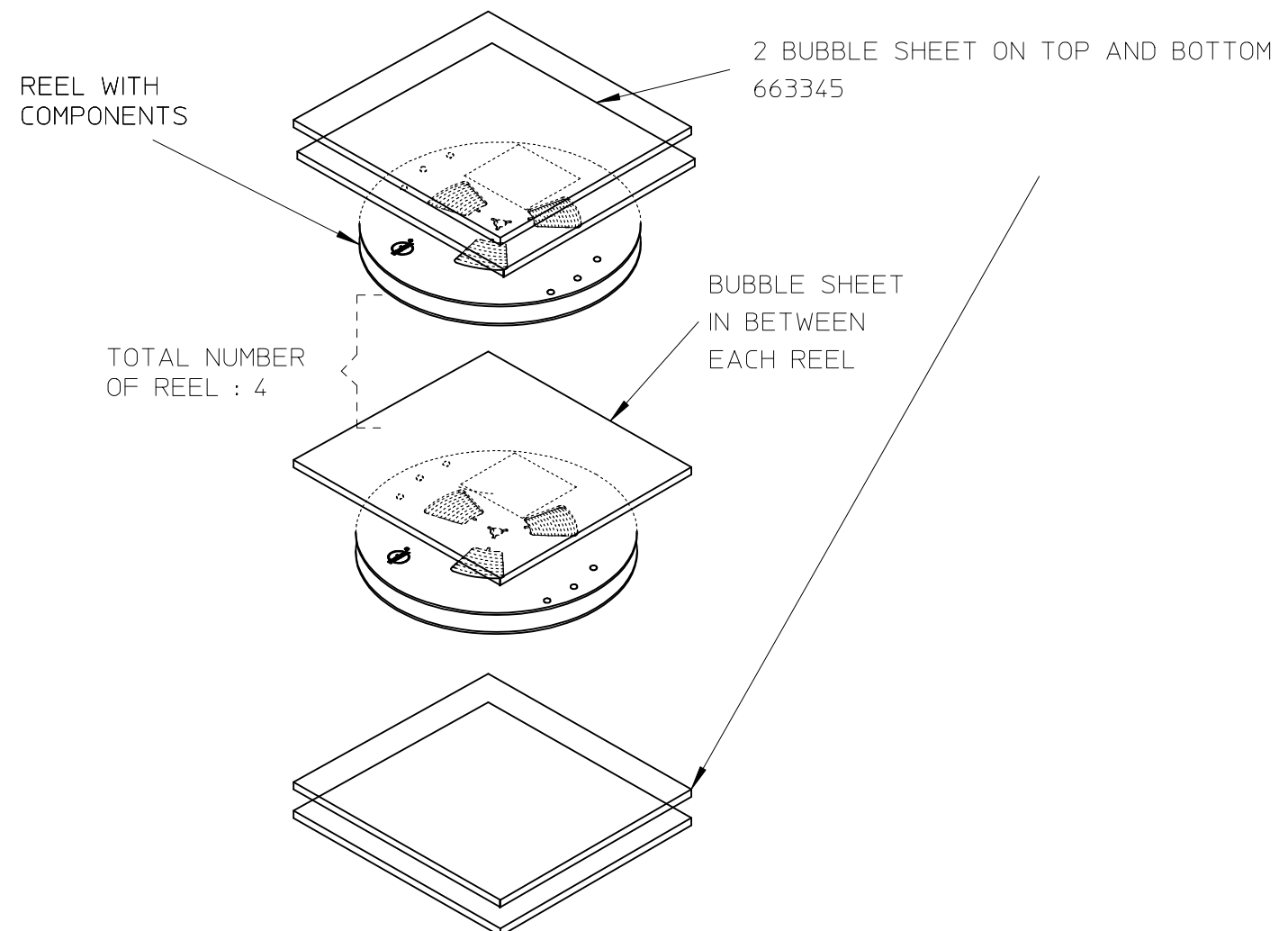

CORNER GUARD:  
78888-1250

CARTON  
899901011

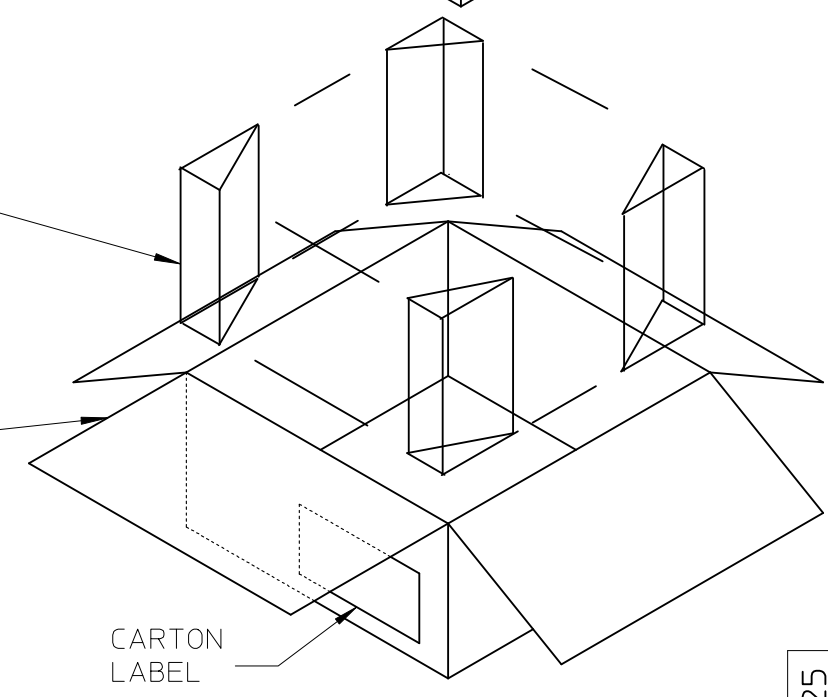

Stack Reel

ADD P/N 78715-0025  
EC NO: S2015-0542  
DRWN:HCGOH 2014/12/04  
CHKD:JESSIECHUA 2014/12/04  
APPR:SHONG 2015/01/05

REV	DESCRIPTION
A2	

QUALITY SYMBOLS	GENERAL TOLERANCES (UNLESS SPECIFIED)	
	mm	INCH
$F_A=0$	4 PLACES $\pm$ ---	$\pm$ ---
$F_E=0$	3 PLACES $\pm$ ---	$\pm$ ---
$F_D=0$	2 PLACES $\pm$ ---	$\pm$ ---
$F_C=0$	1 PLACE $\pm$ ---	$\pm$ ---
$F_B=0$	0 PLACE $\pm$	$\pm$
	ANGULAR $\pm$ ---°	
	DRAFT WHERE APPLICABLE MUST REMAIN WITHIN DIMENSIONS	

DIMENSION STYLE MM ONLY	
DRAWN BY CGOH	DATE 2011/10/11
CHECKED BY SCHEONG	DATE 2011/10/20
APPROVED BY BOKOK	DATE 2011/10/20
MATERIAL NO. SEE TABLE	
SIZE A3	THIS DRAWING CONTAINS INFORMATION THAT IS PROPRIETARY TO MOLEX INCORPORATED AND SHOULD NOT BE USED WITHOUT WRITTEN PERMISSION

SCALE NTS	DESIGN UNITS METRIC	THIRD ANGLE PROJECTION
TITLE PACKAGING SPECIFICATION FOR 78715 (TAPE & REEL) SAS RECEPTACLES		
DOCUMENT NO. PK-78715-003		