

DRAWING MADE IN THIRD ANGLE PROJECTION
 THIS DRAWING IS UNPUBLISHED.
 COPYRIGHT 1983 BY AMP INCORPORATED. ALL INTERNATIONAL RIGHTS RESERVED.

LOC	DIST	ZONE	LTN	DESCRIPTION	DATE	APPD
G	14	A		REVISED PER 0720-0230-93	2/28/93	AMP

REVISIONS
 DATE
 APPD

METPRIG
 DIMENSIONS LISTED IN mm [INCHES]

AMP WIRE RANGE	UL E13288 Listed
16-14 AWG STRANDED	16-14 AWG STRANDED
LR7189 Certified	MILITARY P/N AND CLASS
NOT CERTIFIED	NOT APPLICABLE

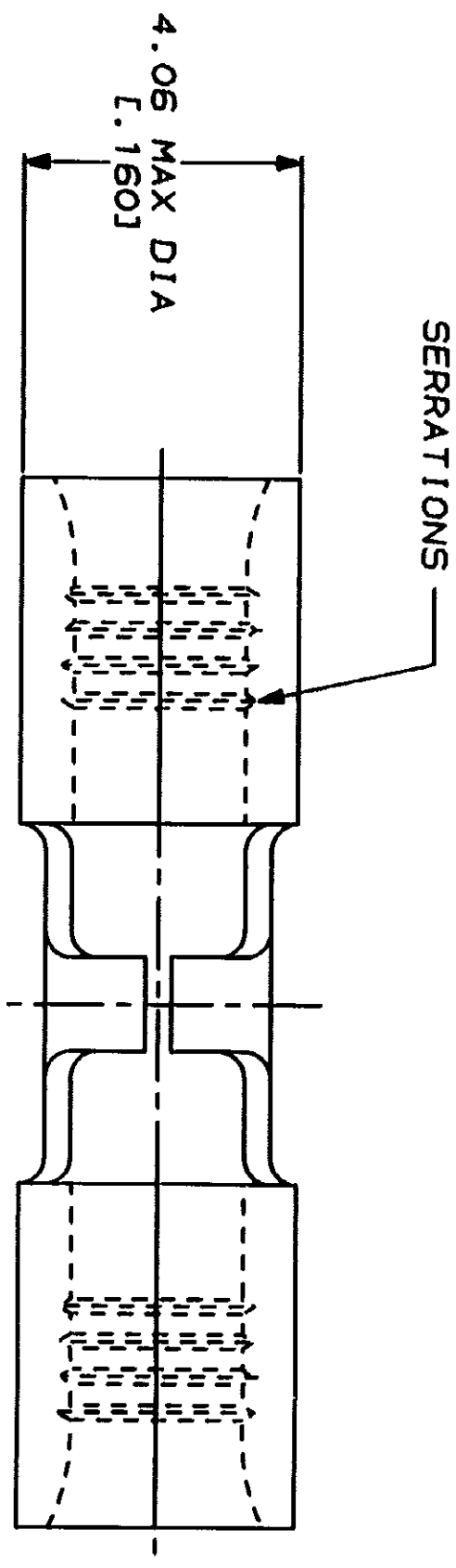

STAMP AMP 16-14* APPROX AS SHOWN
 MAXIMUM LENGTH DOES NOT INCLUDE
 MANUFACTURING TABS

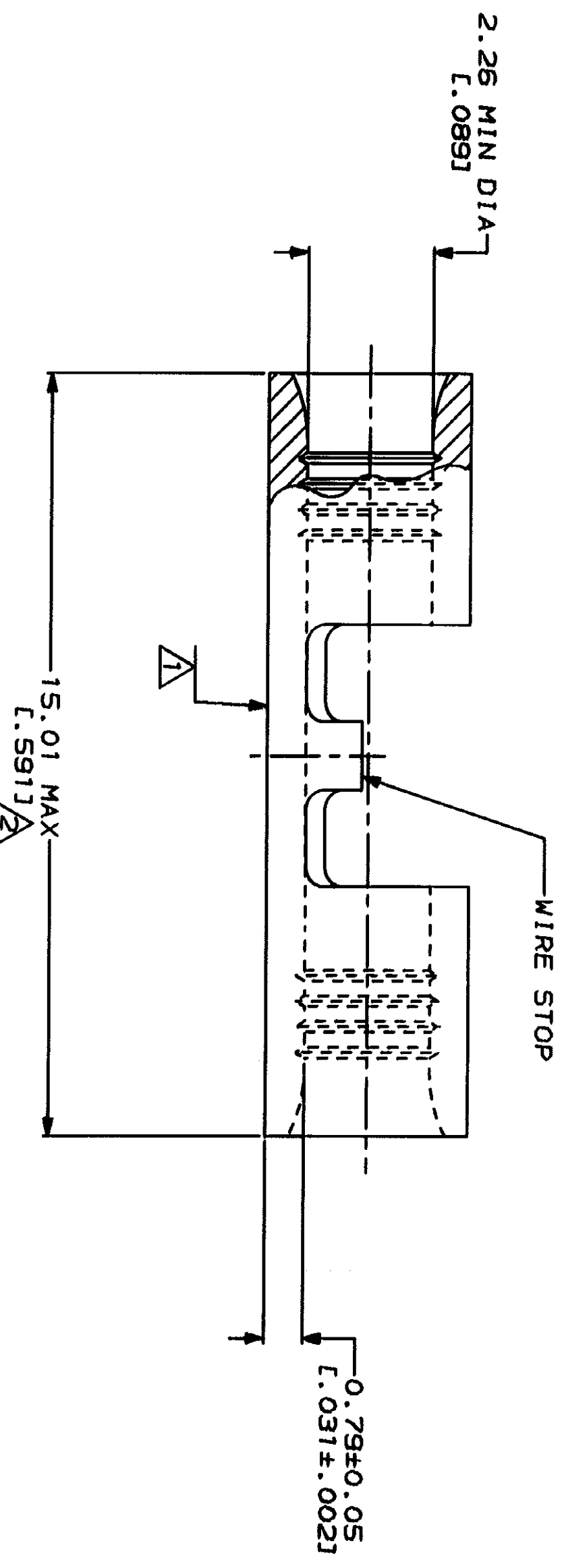

32464
 PART NO

AMP INCORPORATED
 CUSTOMER SERVICE SYSTEMS

MAX RECOMMENDED OPERATING TEMPERATURE: 170°C MAX
 VOLTAGE RATING: NOT APPLICABLE
 WIRE CROSS SECTIONAL AREA RANGE: 1.04-2.62mm² (2,050-5,180) CIR MILS STRANDED

DO NOT SCALE PRINT.
 UNLESS SPECIFIED DIMENSIONS IN THIS DRAWING ARE IN INCHES TOLERANCES ON:
 2 PLG DEC ± .005
 3 PLG DEC ± .002
 ANGLES UNLESS OTHERWISE SPECIFIED

DR 3-1-93 TA BRINKMAN
 CHK 3-1-93 DA PATTERSON
 APPD 3-1-93 DE MILLER
 APPD 3-1-93 JL HECKLEY
 PRODUCT SPEC

AMP Incorporated
 Harrisburg, PA 17105-3508

SPLICE, BUTT,
 STRAP, BUDGET

FOR ADDITIONAL PRODUCT INFORMATION OR COPIES OF DRAWINGS AND TECHNICAL DOCUMENTS
 1-800-522-6752
 PRODUCT INFORMATION CENTER

FOR APPLICATION TOOLING ASSISTANCE CENTER
 1-800-722-1111

FINISH TIN PLATE
 0.00254L.0001001 MIN THK PER MIL-T-10727

APPLICATION SPEC
 WEIGHT

SIZE CAGE CODE DRAWING NO
 00779 32464
 SCALE 10:1 SHEET 1 OF 1

AMP 16-14 REV 3-93
 25-FEB-94 16:44:37 00026463 /files/d90c1123/dw1123/u.splice

CUSTOMER DRAWING