

THIS DRAWING IS UNPUBLISHED.

RELEASED FOR PUBLICATION

© COPYRIGHT - TE Connectivity Ltd.

ALL RIGHTS RESERVED.

REVISIONS

P	LTR	DESCRIPTION	DATE	DWN	APVD
	A	ECR-18-012767	16AUG2018	RSM	AS

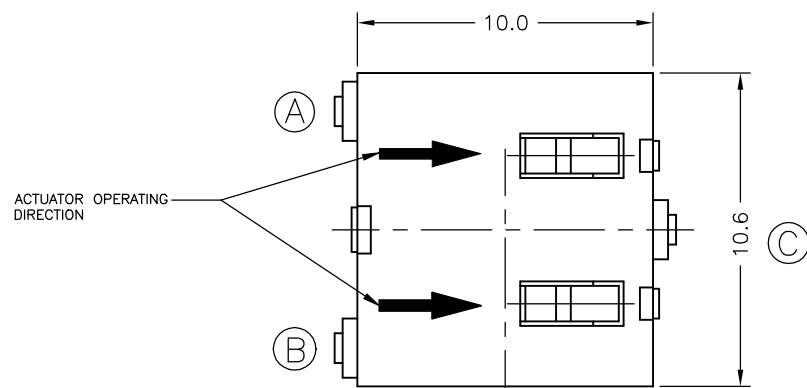

2331331-1
AS SHOWN

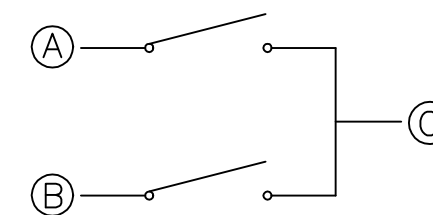

CIRCUIT DIAGRAM

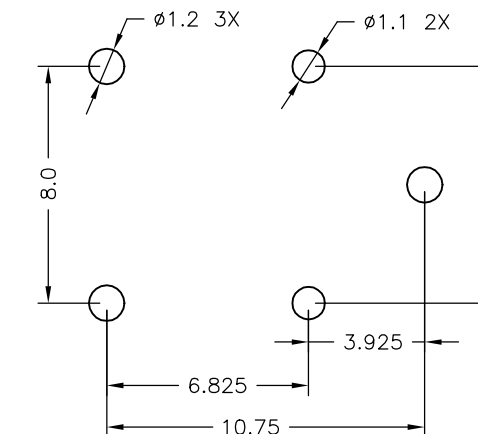
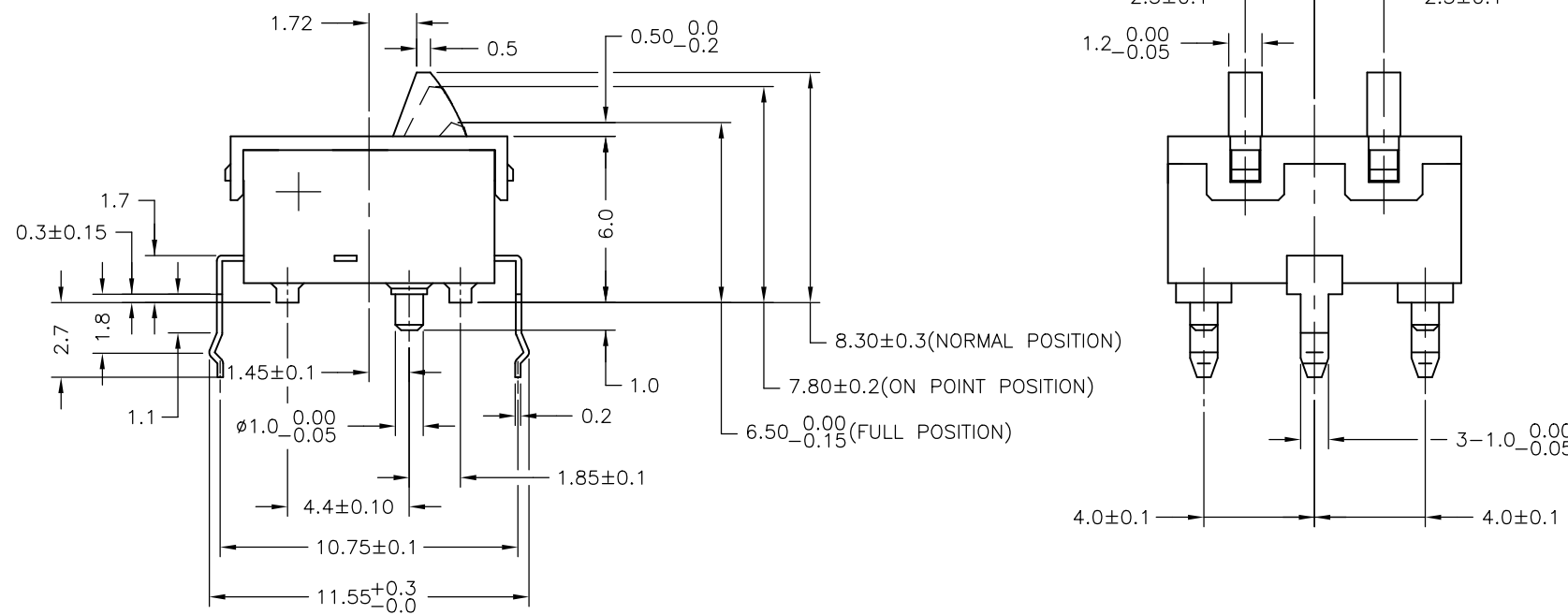
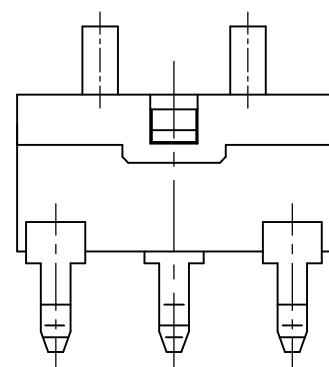

P.C.B. HOLE DIMENSIONS

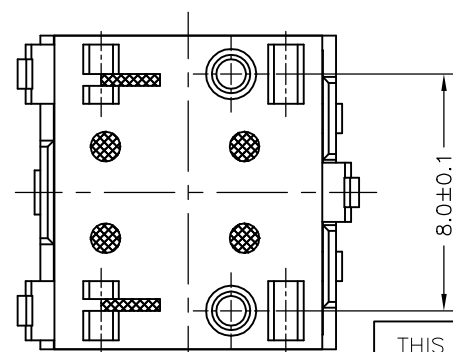

THIS DRAWING IS A CONTROLLED DOCUMENT.		DWN	20APR2018		 TE Connectivity Ltd.
		CHK	20APR2018		
		APVD	20APR2018		
		PRODUCT SPEC	ALEXANDER SHARPE		
		APPLICATION SPEC	-		NAME
		WEIGHT	-		DETECTOR SWITCH, JJP SERIES, 10.6X10.0mm, VERTICAL, SNAP-IN, POSTS
DIMENSIONS: mm		TOLERANCES UNLESS OTHERWISE SPECIFIED:		SIZE	CAGE CODE
0 PLC ± - 1 PLC ± - 2 PLC ± 0.30 3 PLC ± - 4 PLC ± - ANGLES ± -				DRAWING NO	RESTRICTED TO
MATERIAL		FINISH		A3	00779
				C-2331331	
CUSTOMER DRAWING				SCALE	4:1
				SHEET	1 OF 3
				REV	A

4

3

2

1

THIS DRAWING IS UNPUBLISHED.

RELEASED FOR PUBLICATION

REVISIONS

© COPYRIGHT - TE Connectivity Ltd.

ALL RIGHTS RESERVED.

P	LTR	DESCRIPTION	DATE	DWN	APVD
-	-	SEE SHEET 1	-	-	-

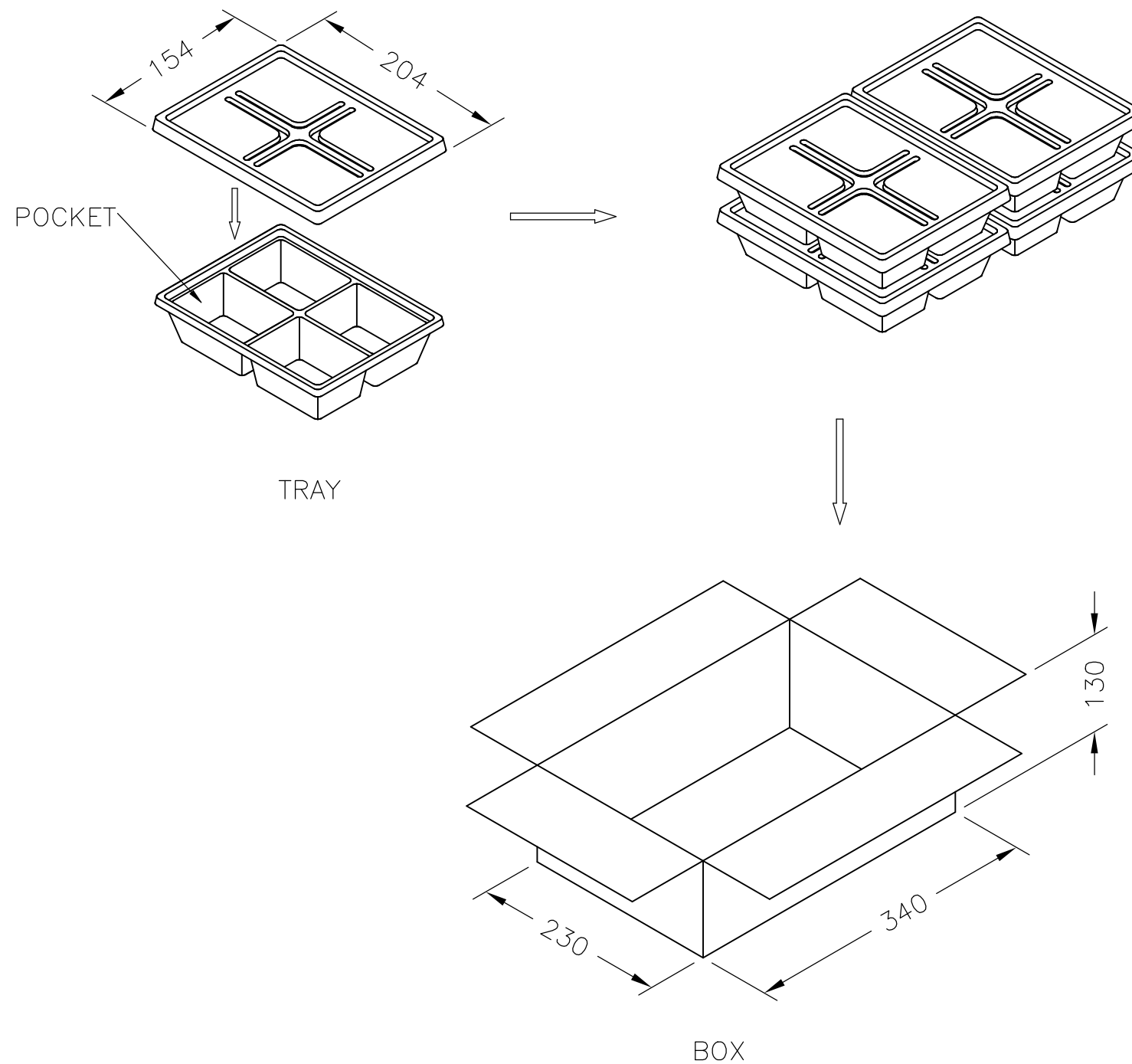

400 SWITCHES PER TRAY, 1,600 PER BOX

THIS DRAWING IS A CONTROLLED DOCUMENT.		DWN	20APR2018		 TE Connectivity Ltd.
		CHK	20APR2018		
		ALEXANDER SHARPE			NAME
		ALEXANDER SHARPE			
		PRODUCT SPEC			DETECTOR SWITCH, JJP SERIES, 10.6X10.0mm, VERTICAL, SNAP-IN, POSTS
		APPLICATION SPEC			
		WEIGHT			RESTRICTED TO
		CUSTOMER DRAWING			—
		SCALE	1:1		SHEET 2 of 3
		REV		A	

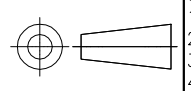
DIMENSIONS:		TOLERANCES UNLESS OTHERWISE SPECIFIED:	
mm			
		0 PLC	± -
		1 PLC	± -
		2 PLC	± 0.30
		3 PLC	± -
		4 PLC	± -
MATERIAL		FINISH	
-		-	

THIS DRAWING IS UNPUBLISHED. RELEASED FOR PUBLICATION
 © COPYRIGHT - TE Connectivity Ltd. ALL RIGHTS RESERVED.

REVISIONS				
P	LTR	DESCRIPTION	DATE	APVD
-	-	SEE SHEET 1	-	-

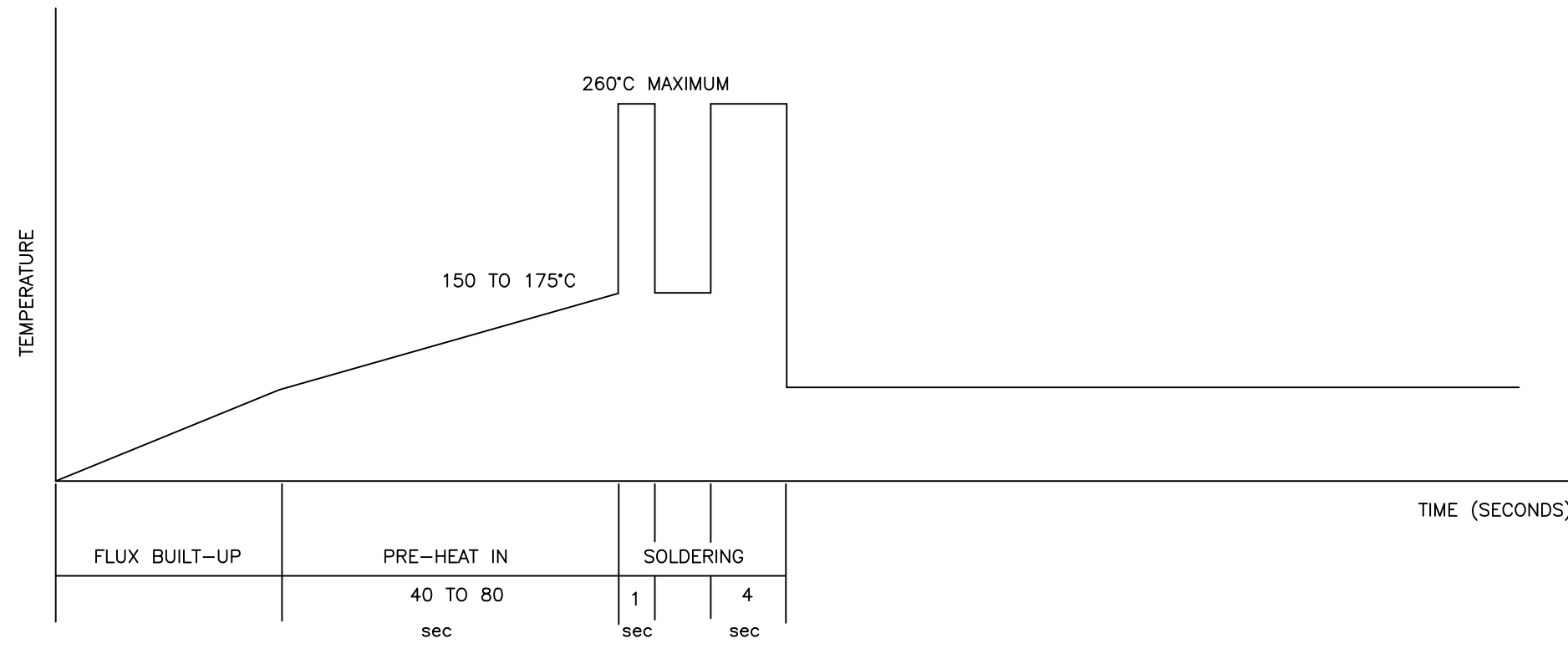

1. RATING: DC 5V 1.0mA
2. OPERATING FORCE: 50gf(MAX)
3. CONTACT RESISTANCE: 500mΩ(MAX)
4. LIFE CYCLE: 100,000 CYCLES WITHOUT LOAD
5. INSULATION RESISTANCE: 100MΩ MINIMUM
6. OPERATING TEMPERATURE: -10 TO 60°C
7. COMPLIANCE- ALL MATERIALS AND FINISHES SHALL COMPLY WITH EU DIRECTIVE 2002/95/EC OF 27JAN 2003 (RoHS)

2 TIMES MAXIMUM
 TEMPERATURE PROFILE

- SOLDERING CONDITIONS:
1. PREHEAT: 150 TO 175°C, 40 TO 80 SECONDS
 2. PEAK TEMPERATURE: 260°C MAXIMUM
 3. SOLDERING AREA TEMPERATURE: 260°C, 1 TO 4 SECONDS, 2 TIMES MAXIMUM

COLOR	RATING	FINISH	MATERIAL	PART NAME
-	-	SILVER CLAD	COPPER ALLOY	CONTACTOR
-	-	SILVER PLATING	BRASS	TERMINAL
NATURAL	UL 94HB	-	THERMOPLASTIC	ACTUATOR
BLACK	UL 94HB	-	THERMOPLASTIC	COVER
BLACK	UL 94HB	-	THERMOPLASTIC	CASE

JJPHOUS830NOPPRLO	2331331-1
SMART PART NUMBER	PART NUMBER

THIS DRAWING IS A CONTROLLED DOCUMENT.		DWN 20APR2018 RAVI.S	TE Connectivity Ltd.	
		CHK 20APR2018 ALEXANDER SHARPE		
		APVD 20APR2018 ALEXANDER SHARPE	NAME DETECTOR SWITCH, JJP SERIES, 10.6X10.0mm, VERTICAL, SNAP-IN, POSTS	
DIMENSIONS: mm		PRODUCT SPEC	SIZE	CAGE CODE
		APPLICATION SPEC	DRAWING NO	RESTRICTED TO
			A3 00779	-
MATERIAL	FINISH	WEIGHT	SCALE 1:1 SHEET 3 OF 3 REV A	
-	-	-	CUSTOMER DRAWING	