

NOTES:

1. COVER & BASE - STEEL  
 -FINISH - PER MIL-F-14072 (SIG.-C)  
 -BASIC FINISH #P-211 TYPE I EXPOSURE  
 -FINAL FINISH PER TT-E-529 ENAMEL  
 SYNTHETIC SEMI-GLOSS NAVY GRAY PER -A3
2. GASKET - SYNTHETIC RUBBER
3. TORSION SPRING - STAINLESS STEEL
4. AXLE - STAINLESS STEEL
5. WASHERS - STEEL - CAD. IRID.

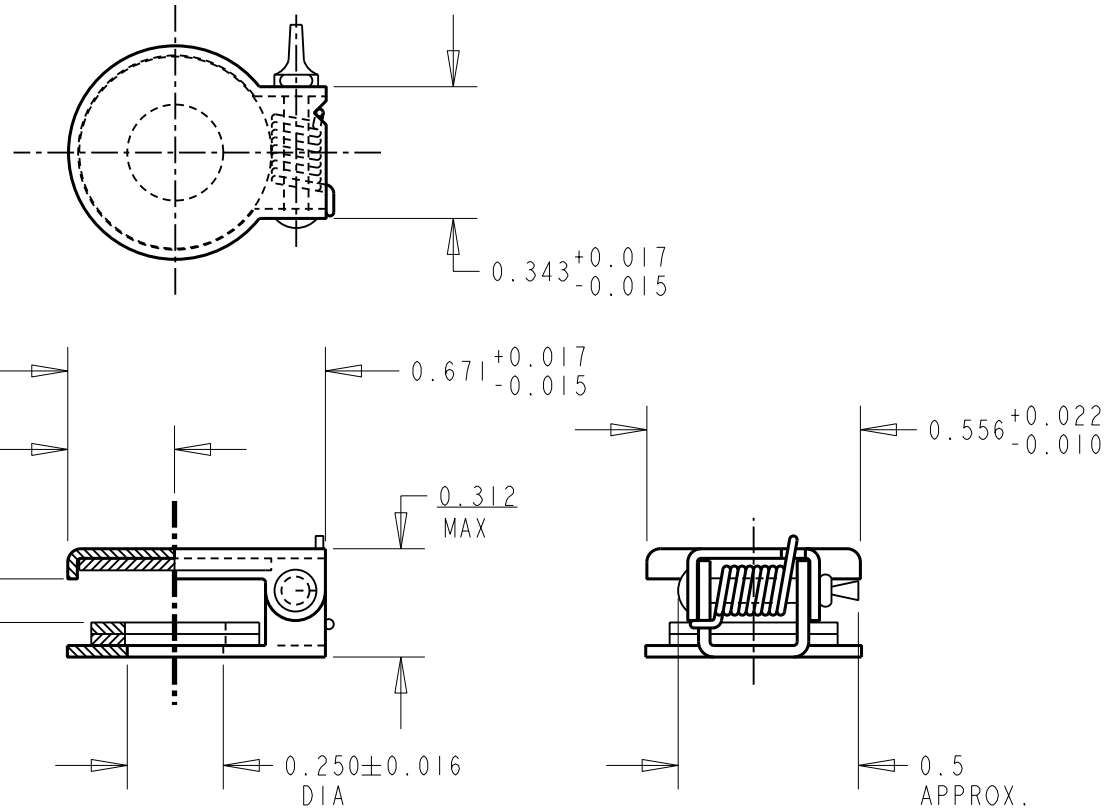

NOTES:

- 1 0.125 APPROX. HIGH HEAD, USE TWO WASHERS.
- 2 0.156 APPROX. HIGH HEAD, USE ONE WASHER.
- 3 0.188 APPROX. HIGH HEAD, USE NO WASHERS.

CUSTOMER DRAWING

					★ STAR SYMBOL DENOTES CRITICAL DIMENSION	THIS DRAWING DESCRIBES A DESIGN CONSIDERED PROPRIETARY IN NATURE, DEVELOPED AND MANUFACTURED BY SWITCHCRAFT INC. AND IS RELEASED ON A CONFIDENTIAL BASIS FOR IDENTIFICATION PURPOSES ONLY.				
					UNLESS OTHERWISE SPECIFIED	SIZE	WIDTH	MULT	LBS/M	TEMPER
					1. ALL DIMENSIONS IN INCHES - TWO PLACE DECIMALS $\pm 0.01$ - THREE PLACE DECIMALS $\pm 0.005$ - ANGLES $\pm 1^\circ$ - ALL DIA. CONCENTRIC WITHIN 0.005 T.I.R.	FINISH			MATERIAL	
					2. FEATURES ON THE SAME CENTERLINE MUST BE ALIGNED WITHIN $\pm 0.002$	SPEC No.			SPEC No.	
					3. REMOVE ALL BURRS	FIRST USED ON		SCALE		<b>Switchcraft®</b>
E	ECO #22434	11-6-98	RC	JF	DATE DRAWN	BY	CHKD	APVD		
REV	ECO NUMBER	DATE	BY	APVD	4-22-64	IRT	CJW 4-22-64	LG 4-23-64		
REVISIONS					DO NOT SCALE DRAWING	NAME			PART No.	REV
						TIP JAX COVER ASS'Y			620	E