

# SAFETY ORGANIZATIONS

THIS FILTER HAS NOT YET BEEN FORMALLY RECOGNIZED, CERTIFIED OR APPROVED BY THE LISTED AGENCY. THEREFORE, ALL TEST/REQUIREMENTS SPECIFIED IN THE LATEST REVISION OF THE FOLLOWING AGENCY STANDARDS HAVE NOT YET BEEN MET:

- UL RECOGNIZED: UL 1283
- CSA CERTIFIED: CSA 22.2, # 8
- VDE APPROVED: VDE 565-3

# OPERATING SPECIFICATIONS

LINE CURRENT/VOLTAGE: 3 AMP, 125 VDC

LINE FREQUENCY: DC

MAXIMUM LEAKAGE CURRENT, EACH LINE TO GROUND: 0.01 mA @ 100VDC

OPERATING AMBIENT TEMP. RANGE: -10°C TO +55°C @ RATED CURRENT,  $I_r$ .

IN AN AMBIENT,  $T_a$ , HIGHER THAN 55°C, THE MAXIMUM OPERATING CURRENT,  $I_o$ , IS AS FOLLOWS:

$$I_o = I_r \sqrt{\frac{90 - T_a}{35}}$$

# RELIABILITY SPECIFICATIONS:

- STORAGE TEMPERATURE: -40°C TO +85°C
- HUMIDITY: 21 DAYS @ 40°C 95% RH.
- CURRENT OVERLOAD TEST: 6 TIMES  $I_r$  FOR 8 SECONDS

# TEST SPECIFICATIONS:

- INDUCTANCE: 1.45 mH NOMINAL
- CAPACITANCE: (MEASURED @ 1KHz, 0.250VAC MAX., 25°C±1°C)
  - LINE TO GROUND: (0.005 µF ±20%)
  - LINE TO LINE: (0.100 µF ±20%)
- DISCHARGE RESISTOR: 3.3 MΩ
- L/G AND L/L I.R.
- NO DISCHARGE RESISTOR: 6000MΩ (MIN.) @ 100VDC, 20°C AND 50% RH

# RECOMMENDED RECEIVING INSPECTION HIPOT:

- LINE TO GROUND: 2250VDC FOR 1 MINUTE
- LINE TO LINE: 1450VDC FOR 1 MINUTE

# FILTER APPROVAL:

THE BEST WAY TO SELECT AND QUALIFY A FILTER IS FOR YOUR ENGINEERING TO TEST THE UNIT IN YOUR EQUIPMENT.

# CATALOG # 3DAF1

ECN #	APPRVD.	DATE
16003	ELC	7/2701

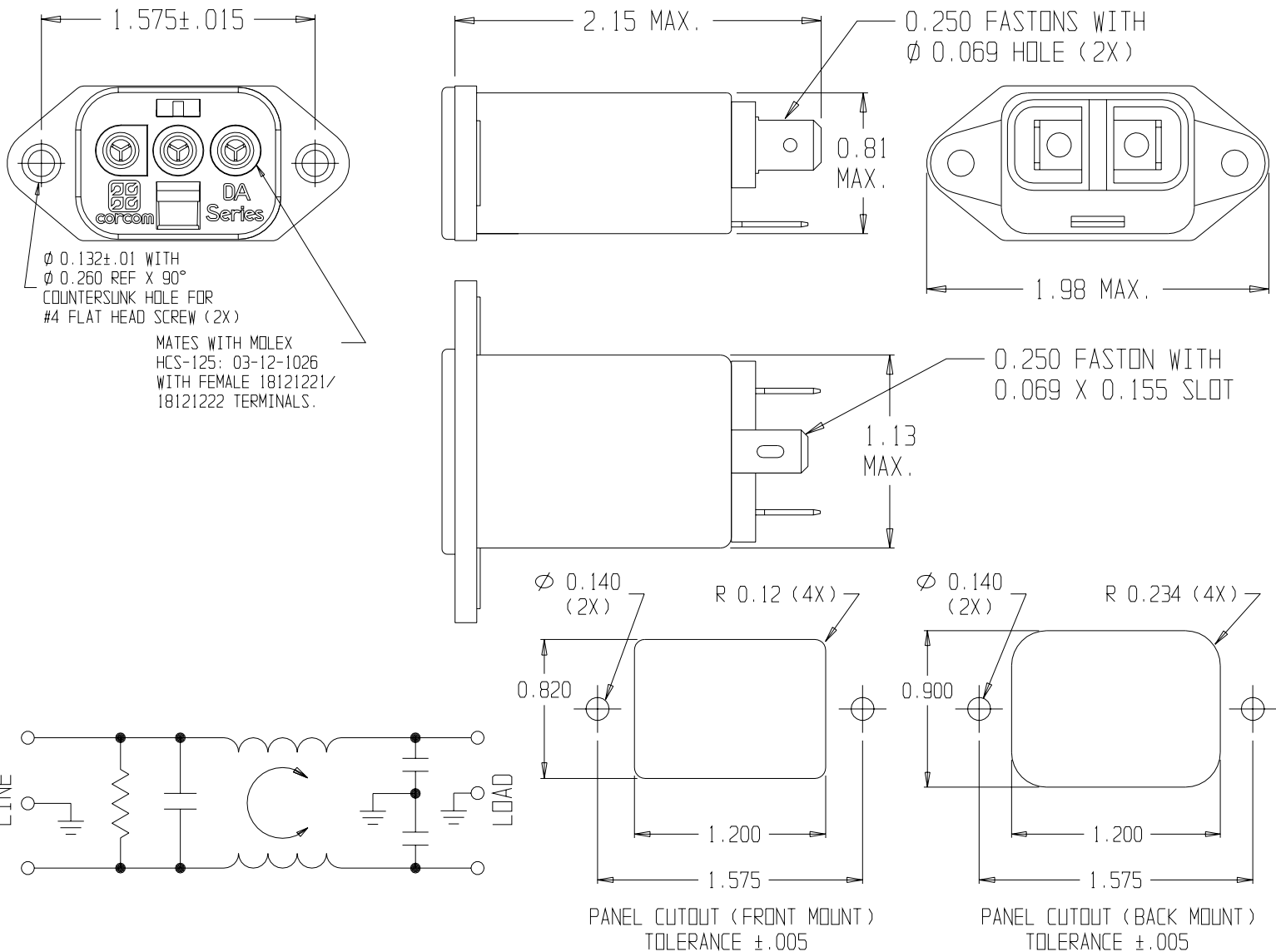

50Ω - 50Ω (MINIMUM) INSERTION LOSS											
FREQUENCY MHz	.05	.10	.15	.50	1	3	5	10	30	100	200
COMMON dB	6	9	11	26	41	48	52	55	46	22	16
DIFF. dB	-	4	7	16	18	37	47	50	43	31	36

THIRD ANGLE PROJECTION

UNLESS OTHERWISE SPECIFIED, TOLERANCE TO BE ±.025 MATERIAL & FINISH: AS SUPPLIED

This document is proprietary to CORCOM INC. and is not to be reproduced nor used for manufacturing purposes except on CORCOM'S prior written consent.

844 E. ROCKLAND RD. LIBERTYVILLE IL 60048

## POWER LINE FILTER

CAD FILE: 3DAF100	DATE: 7/2/01	CATALOG NO.	REV.
SCALE: NTS	DRG. BY: ELC	3DAF1	0