

© 1965 BY AMP INCORPORATED. ALL RIGHTS RESERVED. AMP PRODUCTS COVERED BY PATENTS AND/OR PATENTS PENDING. APPROVED PER GOVT CONTRACT NO.

REVISIONS					
ZONE	LTR	DESCRIPTION	DATE	APPROVED	
A		REVISED	W-777, W-765	10-14-5	M.S. J.H.
B		REVISED	Y-68	1-19-6	M.S. J.H.
C		REVISED SCREW LENGTH PER ECN	Z-15	4/5/67	J.W. B.M.
D		REV. PER ECN D-644		10-6-75	J.W.
E		REV. / ECN H-220		8-14-80	J.W.
F		REV. / ECN R-2305		7-30-86	MPH J.M.
G		REV PER ELO-05-001A12		05/05	AD/DE
H		REV PER ECO-05-005359		11/05	PY/DE

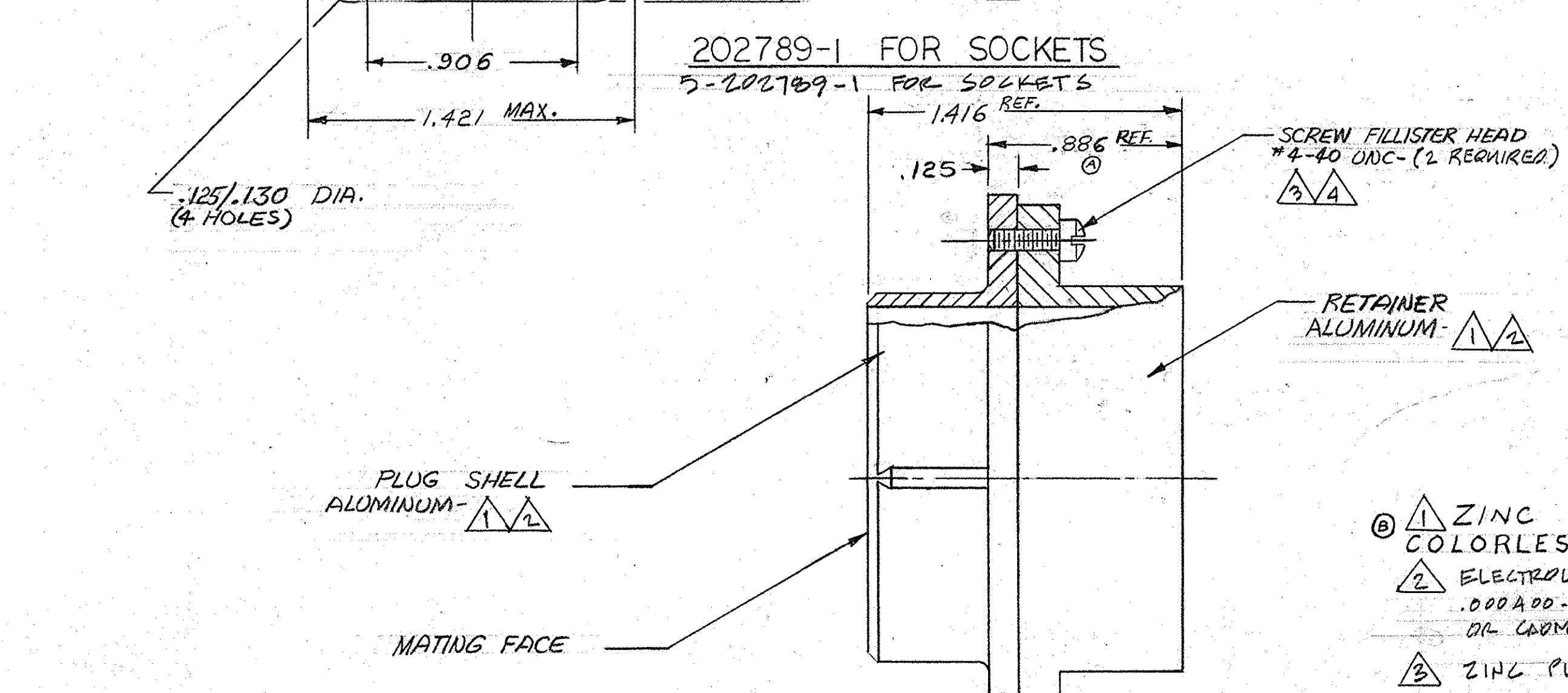
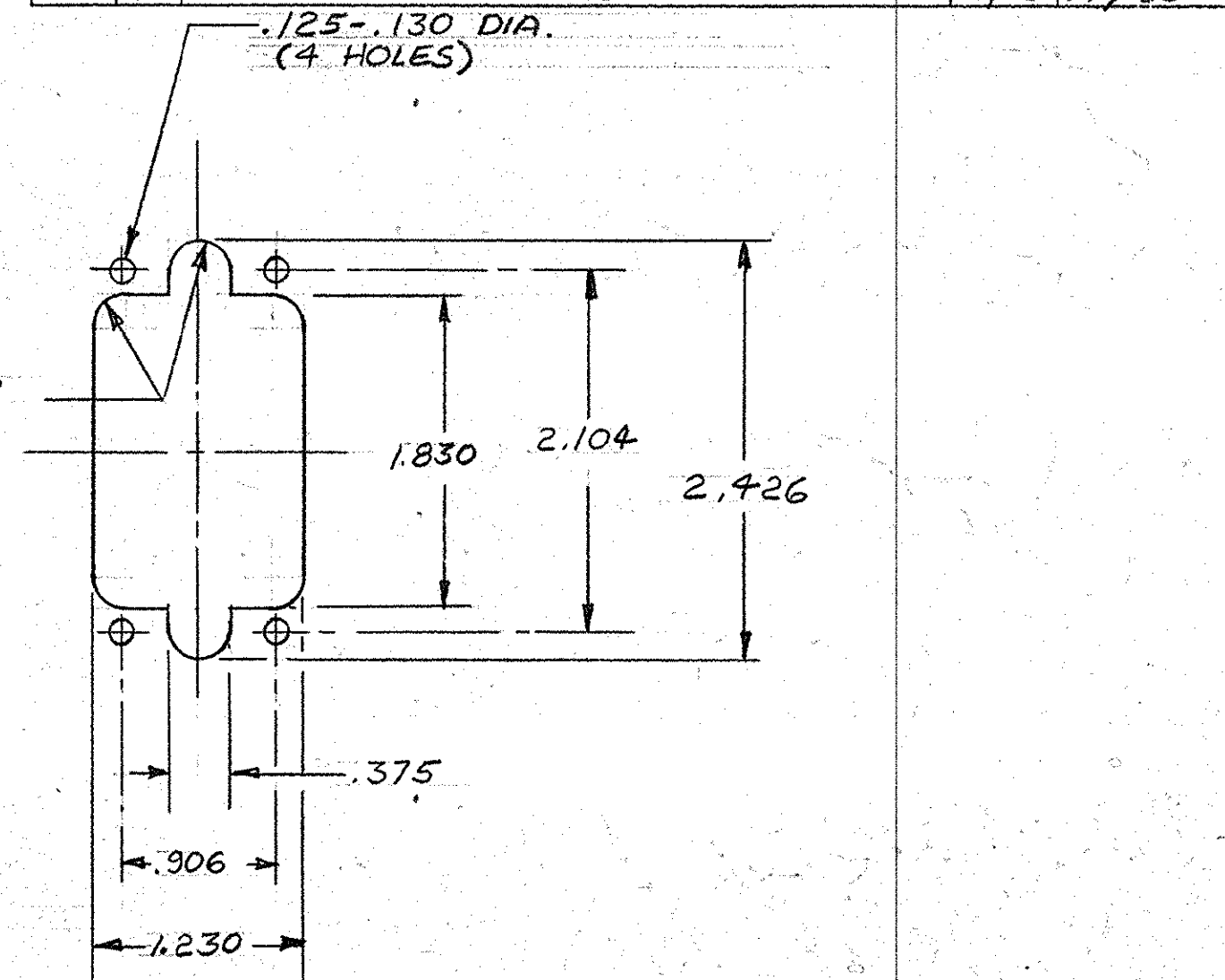
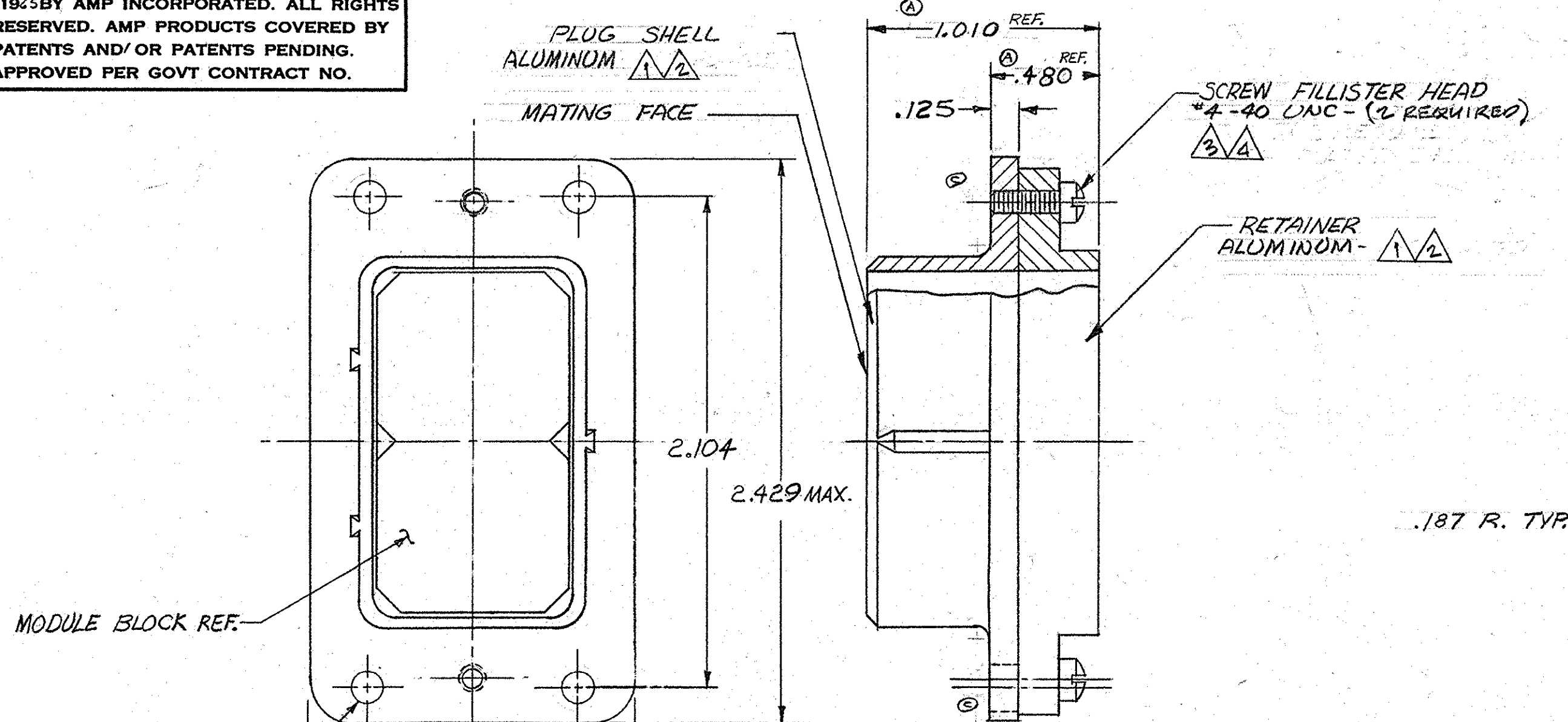

- ① ZINC PLATE PER ASTM-B-633 CLASS 3, TYPE II COLORLESS SUPPLEMENTARY CHROMATE.
- ② ELECTROLESS NICKEL PLATE PER SAE-AMS-C-26074 .000 ADD-.000800 THK (NO INTENTIONAL ADDITIONS OF LEAD OR CADMIUM PER SPE STD 230-700).
- ③ ZINC PLATED COLD ROLLED. ④ PASSIVATED STAINLESS STEEL.

202789-2 FOR PINS  
5-202789-2 FOR PINS

②	①	5-202789-2
②	①	5-202789-1
①	③	202789-2
①	③	202789-1

SUPERSEDED BY 5-202789-2  
SUPERSEDED BY 5-202789-1

AMP INFO		QTY REQD	NOMENCLATURE OR DESCRIPTION	PART OR IDENTIFYING NO
LOC	PRINT DIST			
R	39/H			
LIST OF MATERIALS OR PARTS LIST				
UNLESS OTHERWISE SPECIFIED DIMENSIONS ARE IN INCHES TOLERANCES ON		CONTRACT NO		
FRACTIONS ± $\frac{1}{16}$	DECIMALS ± .005	ANGLES ± $\frac{1}{2}$	DR <i>E. Benninger</i>	DATE 8-30-65
MATERIAL			CHK <i>J. St. Heide</i>	DATE 9/2/65
HEAT TREAT			DSGN ENGR <i>J. Williams</i>	DATE 7-2-65
FINISH			APPD <i>F. B. Miller, Jr.</i>	DATE 9-2-65
			DSGN APPD	SIZE C
			OTHER APPD	CODE IDENT NO 00779
				NUMBER 202789
			SCALE 2-1	WT CALC ACTUAL SHEET

AMP INCORPORATED  
HARRISBURG, PENNSYLVANIA

PLUG ASSEMBLY, MODULE  
SERIES "G", (2 BLOCK)

CUSTOMER DRAWING