

CODE No.	CONTACT	A	B	C	D	E	F
CL537-0626-9-81	10	4.6	2.0	2.7	3.1	4.1	2.8
CL537-0915-6-81	14	5.6	3.0	3.7	4.1	5.1	3.8
CL537-0628-4-81	20	7.1	4.5	5.2	5.6	6.6	5.3
CL537-0630-6-81	30	9.6	7.0	7.7	8.1	9.1	7.8
CL537-0637-5-81	32	10.1	7.5	8.2	8.6	9.6	8.3
CL537-0631-9-81	36	11.1	8.5	9.2	9.6	10.6	9.3
CL537-0632-1-81	40	12.1	9.5	10.2	10.6	11.6	10.3
CL537-0634-7-81	50	14.6	12.0	12.7	13.1	14.1	12.8
CL537-0636-2-81	60	17.1	14.5	15.2	15.6	16.6	15.3
CL537-0638-8-81	80	22.1	19.5	20.2	20.6	21.6	20.3

RECOMMENDED METAL MASK (10:1)

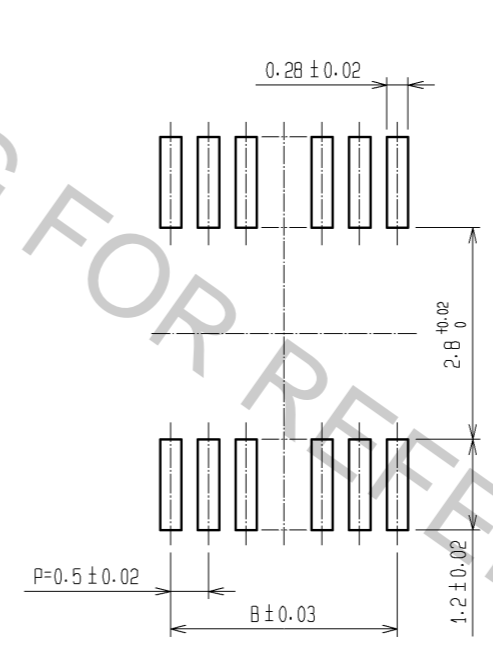

RECOMMENDED PATTERN (10:1)

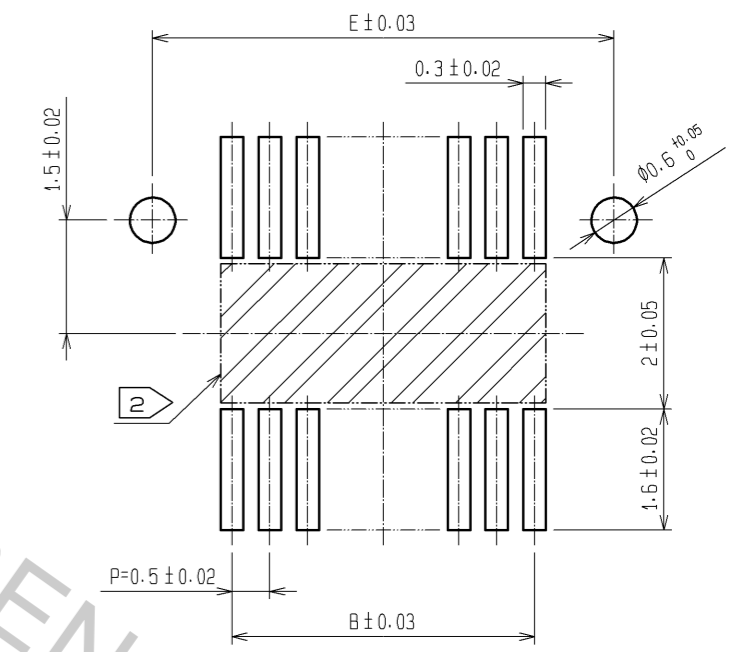

RECOMMENDED THICKNESS OF SOLDER PASTE : 120 μm

NOTES 1 : LEAD CO-PLANARITY SHALL BE 0.08 mm MAX.  
 2 IF THERE IS PATTERN ON PART, THERE IS A POSSIBILITY THAT IT WILL MAKE CONTACT WITH THE LEADS.

2	PHOSPHOR BRONZE	CONTACT AREA:GOLD PLATED 0.2μm min	6	PS	CLEAR (REINFORCEMENT COLLAR)			
		LEAD AREA:GOLD PLATED 0.015μm min	5	PS	BLACK (PLASTIC REEL)			
		OTHERS(UNDER PLATING):NICKEL PLATED 2μm min	4	POLYESTER	CLEAR (COVER TAPE)			
1	POLYAMIDE	UL94V-0-NATURAL (BEIGE)	3	PS	CLEAR (EMBOSSED CARRIER TAPE)			
NO.	MATERIAL	FINISH . REMARKS	NO.	MATERIAL	FINISH . REMARKS			
UNITS mm		SCALE 5 : 1	COUNT 	DESCRIPTION OF REVISIONS		DESIGNED	CHECKED	DATE
<b>HRS</b> HIROSE ELECTRIC CO., LTD.		APPROVED : KH. IKEDA	13.08.06	DRAWING NO. EDC3-163505-77				
		CHECKED : YH. MICHIDA	13.08.05	PART NO. DF12A(3.0)-*DS-0.5V(81)				
		DESIGNED : YN. SAKAMOTO	13.08.05	CODE NO. CL537				
		DRAWN : KR. AJITO	13.08.05					

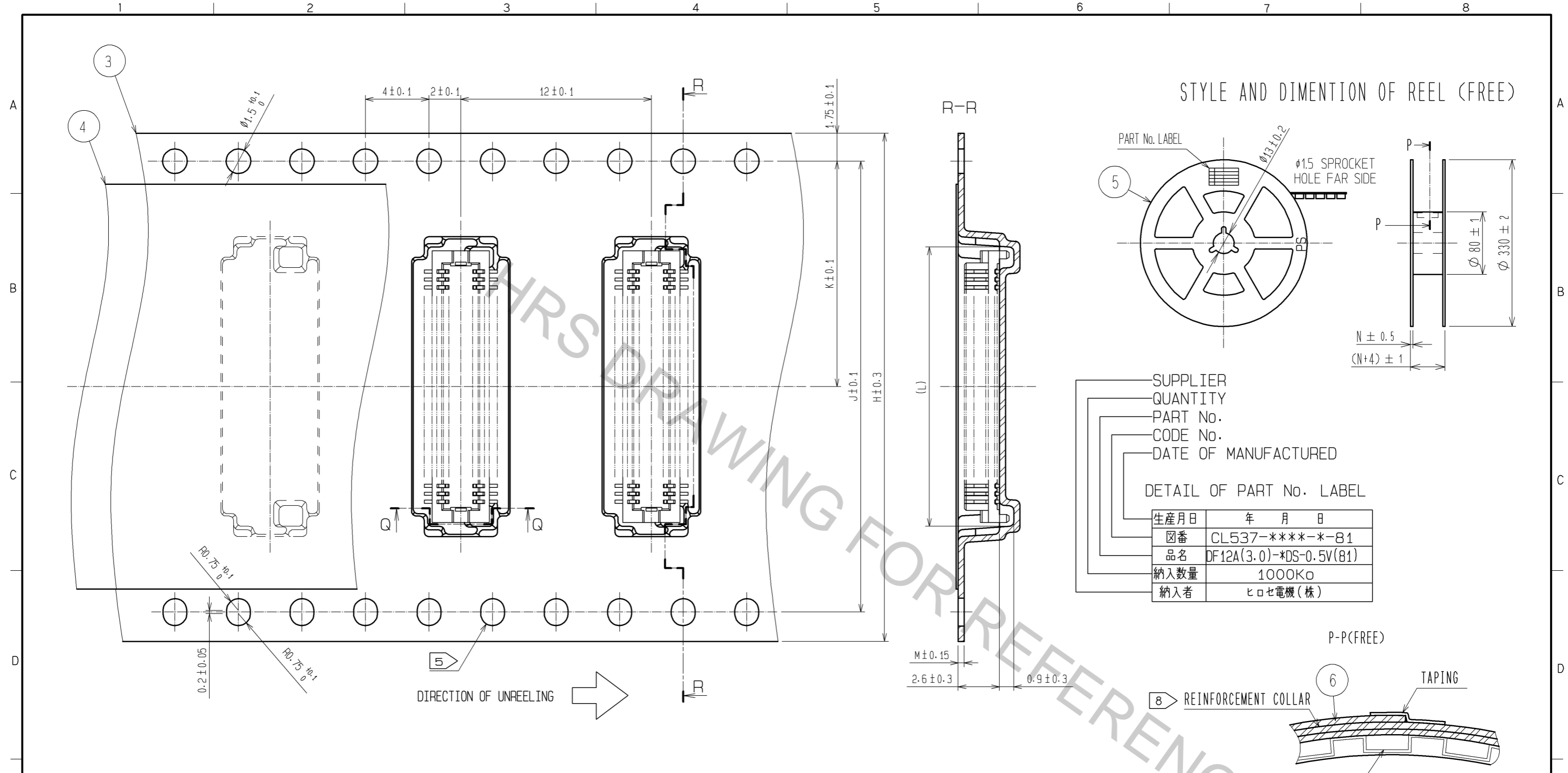

CODE No.	CONTACT	H	J	K	L	M	N
CL537-0626-9-81	10	16	-	7.5	6.4	0.30	17.5
CL537-0915-6-81	14	16	-	7.5	7.4	0.30	17.5
CL537-0628-4-81	20	16	-	7.5	9	0.38	17.5
CL537-0630-6-81	30	24	-	11.5	11.5	0.38	25.5
CL537-0637-5-81	32	24	-	11.5	12	0.30	25.5
CL537-0631-9-81	36	24	-	11.5	12.6	0.38	25.5
CL537-0632-1-81	40	24	-	11.5	14	0.38	25.5
CL537-0634-7-81	50	24	-	11.5	16.1	0.38	25.5
CL537-0636-2-81	60	32	28.4	14.2	18.6	0.38	33.5
CL537-0638-8-81	80	44	40.4	20.2	23.8	0.38	45.5

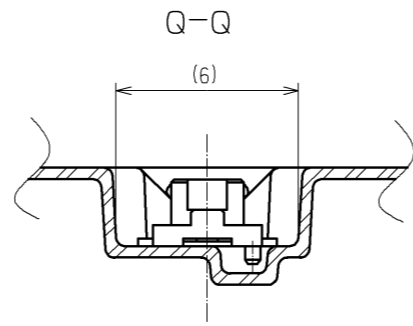

- NOTES 3 1 REEL 1000 CONNECTORS.  
 4 AT THE BEGINNING OF THE REEL, 30 COMPONENTS SHALL BE EMPTY. AT THE END OF THE REEL, 20 COMPONENTS SHALL BE EMPTY.  
 5 WHEN THE TAPE WIDTH IS 32 mm OR 44 mm, SPROCKET HOLES SHALL BE SET ON BOTH SIDE OF REEL AS SHOWN ON THIS DRAWING.  
 6 PEEL FORCE REFERS TO JIS C 0806. (IEC 60286-3)  
 7 THE REEL IS PACKED WITH A POLYETHYLENE MATERIAL, TOGETHER WITH A DRYING AGENT.  
 8 AFTER PACKING, ROLL 2 METERS OF THE REINFORCEMENT COLLAR TO OUTER CIRCUMFERENCE OF TAPE AND REEL POCKET, AND TAPE DOWN AT THE END THE COLLAR.

<b>HRS</b>	DRAWING NO.	EDC3-163505-77
	PART NO.	DF12A(3.0)-*DS-0.5V(81)
	CODE NO.	CL537
		△ 2/2