

THIS DRAWING IS UNPUBLISHED. RELEASED FOR PUBLICATION
 © COPYRIGHT BY TYCO ELECTRONICS CORPORATION. ALL RIGHTS RESERVED.

LOC	DIST	REVISIONS			
P	LTR	DESCRIPTION	DATE	DWN	APVD
AJ	16	A	REVISED PER OS14-0150-05	11NOV2005	REH JL

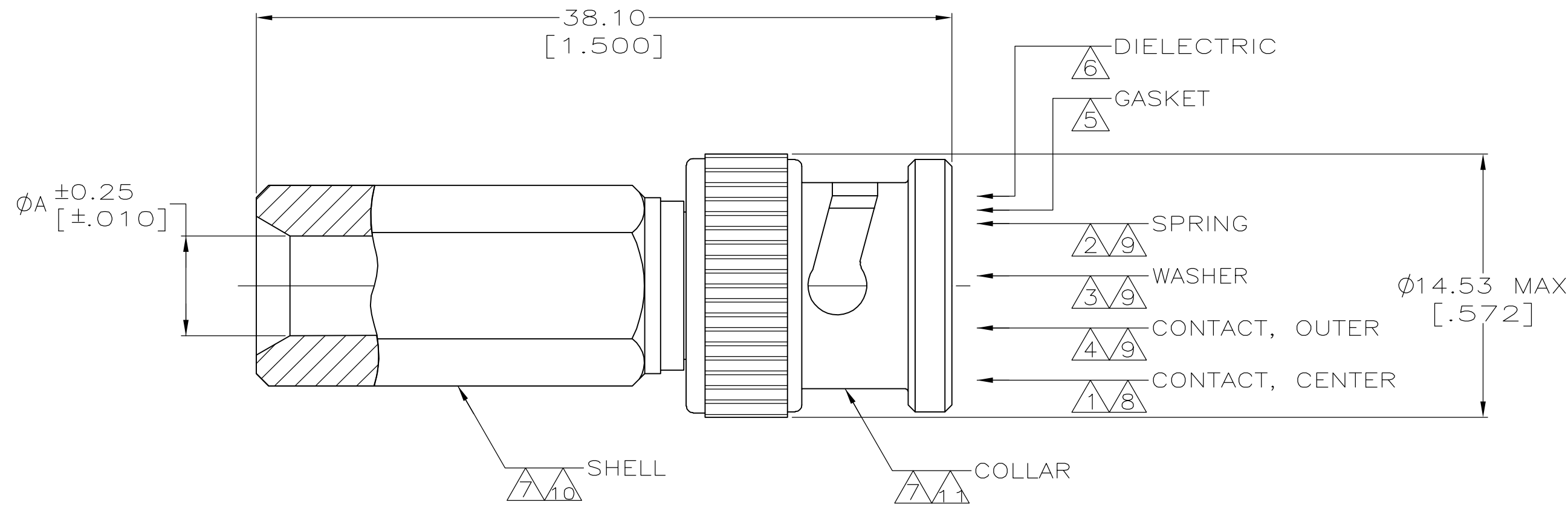

- 1 PHOSPHOR BRONZE PER ASTM-B-139
- 2 CARBON STEEL
- 3 BRASS PER MIL-C-50
- 4 BRASS PER QQ-B-626
- 5 SILICONE RUBBER PER ZZ-R-765
- 6 POLYMETHYLPENTENE: GENERAL PURPOSE
- 7 ZINC DIE CAST PER QQ-Z-363
- 8 GOLD PLATING PER ASTM-B-488
0.38µm [.000015] MIN THICKNESS
- 9 NICKEL PLATING PER QQ-N-290
2.54µm [.000100] MIN THICKNESS
- 10 NICKEL PLATING PER QQ-N-290
3.81µm [.000150] MIN THICKNESS
- 11 NICKEL PLATING PER QQ-N-290
4.45µm [.000175] MIN THICKNESS
- 12. USE INSTRUCTION SHEET 408-6996

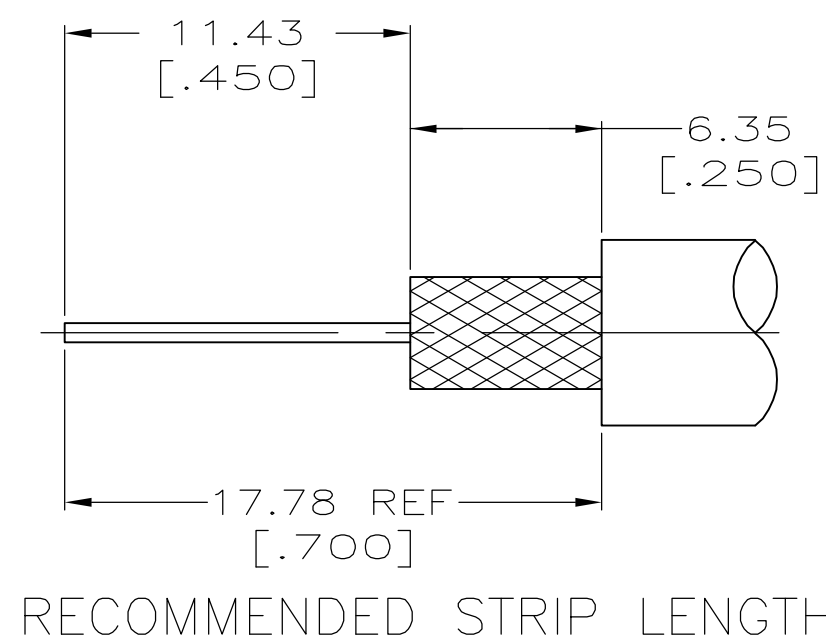

RG-59/U	5.49 [.216]	5414265-3
CABLE	A	PART NUMBER

THIS DRAWING IS A CONTROLLED DOCUMENT.		DWN J. HAVENER 02NOV2005	tyco Tyco Electronics Corporation	
DIMENSIONS: mm [INCHES]		CHK J. HAVENER 02NOV2005	Harrisburg, PA 17105-3608	
TOLERANCES UNLESS OTHERWISE SPECIFIED:		APVD J. LIPPERT 02NOV2005	NAME PLUG ASSEMBLY, 50 OHM, TWIST-ON, BNC	
0 PLC ± -		PRODUCT SPEC	SIZE	
1 PLC ± -		APPLICATION SPEC	CAGE CODE	
2 PLC ± 0.51 [.020]		WEIGHT	DRAWING NO	
3 PLC ± -		RESTRICTED TO	A2 00779 C=5414265	
4 PLC ± -		CUSTOMER DRAWING	SCALE 4:1 SHEET 1 of 1 REV A	
ANGLES ± -				
FINISH				
MATERIAL SEE NOTES				
FINISH SEE NOTES				