

DRAWING MADE IN THIRD ANGLE PROJECTION

© COPYRIGHT 1978 BY AMP INCORPORATED, HARRISBURG, PA.  
ALL INTERNATIONAL RIGHTS RESERVED. AMP INCORPORATED PRODUCTS  
COVERED BY U. S. AND FOREIGN PATENTS AND/OR PATENTS PENDING.

		REVISIONS				
P	F	ZONE	LTR	DESCRIPTION	DATE	APPROVED
✓	✓	0		PER NPS 78-0183	REP 11/18/83	JTW
✓	✓	A		-2 INACTIVE P.994B	PMF 3-9-83	JTW
✓	✓	B		REV PER G-4732	JT 7/26/83	JTW
✓	✓	C		OBS. -2 PER G 3574	DKS 12-7-88	JTW
		D		REACT-2 REV/G-5377 AND 0720-0056-93	3-30-93	TG/ME
		E		REV 10720-0956-96	6-26-96	ME/ITM

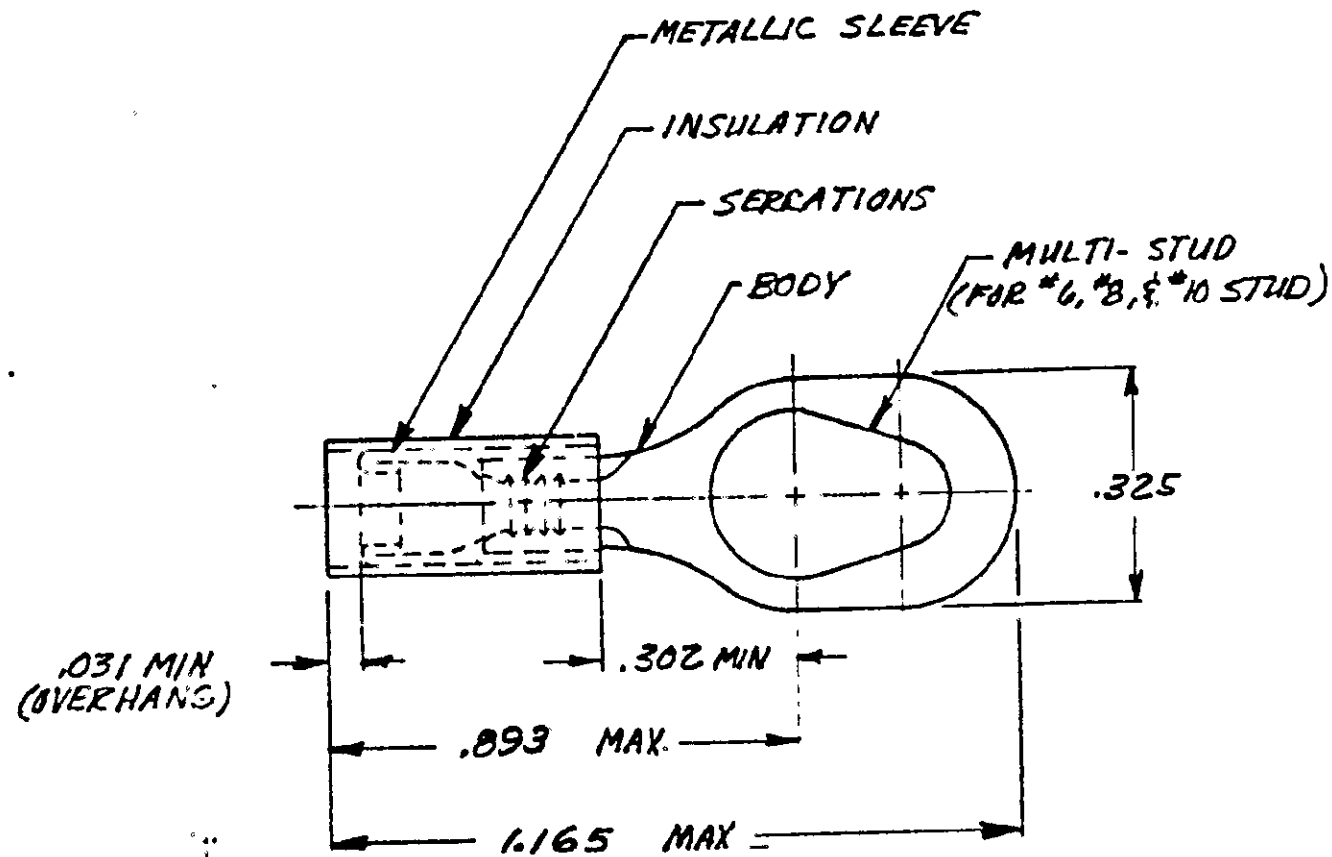

TONGUE MATERIAL THICKNESS =  $.0285 \pm .002$   
FOR .150 TO .230 WIRE INS. DIA.

⚠ SUPERSEDED BY 54773-1

QTY.	DESCRIPTION	MATERIAL & FINISH	PART NO
50	LOOSE PC, BOX	BODY: COPPER (QQ-C-576) TIM PL. (MIL-T-10727)	8-54773-2
1	WIRE TERMINAL	SLEEVE: COPPER (QQ-C-576) NICKEL PL (QQ-N-290) INSULATION: NYLON COLOR: YELLOW	54773-1

UNLESS OTHERWISE SPECIFIED DIMENSIONS ARE IN INCHES. TOLERANCES ON: DECIMALS $\pm .008$ ANGLES $\pm 5^\circ$	CONTRACT NO	AMP INCORPORATED Harrisburg, Pa
	DR <i>R.E. Bertram 12/2/78</i>	
MATERIAL <b>SEE TABLE</b>	CHK <i>JTW 12-1-78</i>	NAME <b>TERMINAL P.I.D.G. - RING - MULTI-STUD WIRE SIZE: 12-10</b>
FINISH <b>SEE TABLE</b>	APPD	SIZE <b>B</b> CODE IDENT NO <b>00779</b> DRAWING NO <b>54773</b>
	DSGN APPD <i>JH Romslaw 12-1-78</i>	SCALE <b>N.T.S.</b> SHEET <b>1 OF 1</b>
	OTHER APPD	

54773-1	54773-2 ⚠
PT. No.	PT. No. ON TAPE