

100 W 3 phase inverter featuring L6390 and STD5NK52ZD for vector control STEVAL-IHM021V1

Introduction

The 100 W 3-phase inverter featuring the L6390 and STD5NK52ZD for field-oriented control (FOC) of permanent magnet synchronous motors (PMSM) demonstration board (also referred to by its order code STEVAL-IHM021V1) is a 3-phase inverter designed to perform the FOC of sinusoidal-shaped back-EMF PMSM - with or without sensors - with nominal power up to 100 W.

The device's flexible, open and high-performance design consists of a 3-phase inverter bridge based on the STD5NK52ZD-1 power MOSFET in IPAK package and L6390 device, the latest high-voltage half-bridge gate driver family featuring an integrated comparator for hardware protection implementation (for example, against over-current, over-temperature, etc) and an embedded operational amplifier suitable for advanced current sensing. The system has been specifically designed to achieve accurate and fast conditioning of the current feedback, thereby matching the requirements typical of high-end applications such as field oriented motor control.

The board is compatible with 110 and 230 Vac mains and includes a power supply stage with VIPer12AS-E (in buck configuration) to generate the +15 V and +3.3 V supply voltage required by the application. Finally, the board can be interfaced with the STM3210B-EVAL (STM32 microcontroller demonstration board) through a dedicated connector.

Figure 1. STEVAL-IHM021V1 demonstration board



Contents

- 1 Main features 5**
 - 1.1 Target applications 5
- 2 System architecture 6**
- 3 Safety and operating instructions 7**
 - 3.1 General 7
 - 3.2 Intended use of the demonstration board 7
 - 3.3 Installing the demonstration board 7
 - 3.4 Electronic connections 7
 - 3.5 Operating the demonstration board 8
- 4 L6390 characteristics 9**
 - 4.1 Main features 9
 - 4.2 Block diagram 9
- 5 STD5NK52ZD-1 characteristics 10**
- 6 Electrical characteristics of the board 11**
- 7 Board architecture 12**
 - 7.1 Power supply 12
 - 7.2 Gate driving 13
 - 7.3 Amplifying network 13
 - 7.4 Brake feature 13
 - 7.5 Temperature feedback 13
- 8 Board schematics 14**
 - 8.1 Gate driving circuit 16
 - 8.2 Overcurrent protection 16
 - 8.3 Current sensing amplifying network 17
 - 8.4 Brake function 18

9	Using the STEVAL-IHM021V1 with the STM32 FOC firmware library .	20
9.1	Environmental considerations	20
9.2	Hardware requirements	21
9.3	Software requirements	21
9.4	Software modifications	21
10	References	22
11	Revision history	23

List of figures

Figure 1.	STEVAL-IHM021V1 demonstration board	1
Figure 2.	Motor control system architecture	6
Figure 3.	L6390 block diagram	9
Figure 4.	STD5NK52ZD-1	10
Figure 5.	STEVAL-IHM021V1 block diagram	12
Figure 6.	Power supply block diagram	12
Figure 7.	Inverter schematics	14
Figure 8.	Power supply schematics	15
Figure 9.	Detailed gate driving circuit	16
Figure 10.	Overcurrent protection	16
Figure 11.	Current sensing amplifying network	17
Figure 12.	Brake circuit	19

1 Main features

The 100 W 3-phase inverter has the following characteristics.

- Wide range input voltage
- Maximum power-up to 100 W at 230 Vac input.
- Power MOSFET STD5NK52ZD-1 (4.4 A, 520 V)
- Compatible with other power MOSFET in IPAK packages
- 15 V auxiliary power supply connector
- Connector for interfacing with the STM3210B-EVAL board.

1.1 Target applications

- Refrigerator compressors
- Dishwasher pumps.

2 System architecture

A generic motor control system can be basically schematized as the arrangement of four main blocks ([Figure 2](#)).

- A control block: its main tasks are to accept user command and motor drive configuration parameters, and to provide digital signals to implement the appropriate motor driving strategy
- A power block that makes a power conversion from the DC bus transferring it into the motor by means of a 3-phase inverter topology
- The motor itself. The STEVAL-IHM021V1 board can drive any PMSM but the FOC itself is conceived for sinusoidal-shaped back-EMF
- A power supply block that can accept from 86 to 260 Vac input voltages and provide the appropriate levels to supply both the control block and power block devices.

Figure 2. Motor control system architecture

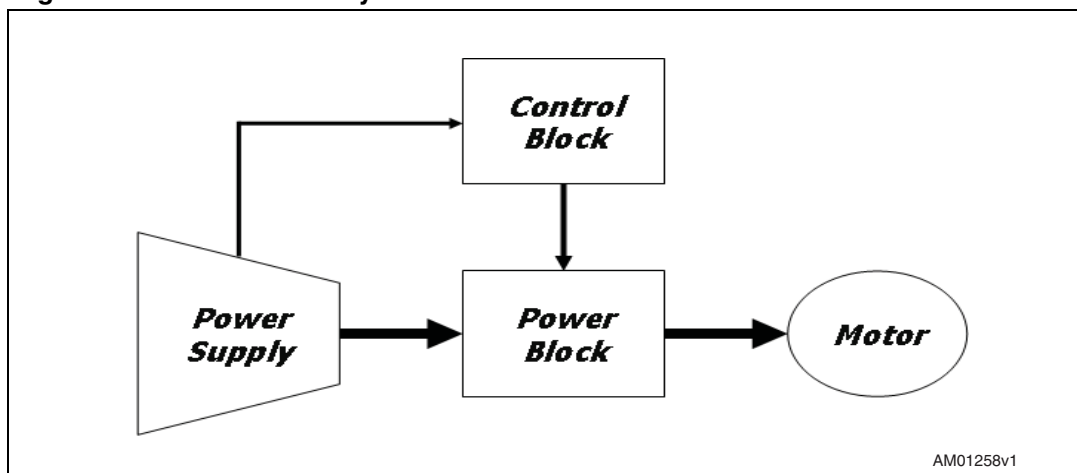

Of the above motor control system architecture, the STEVAL-IHM021V1 includes the power supply and power block hardware blocks.

The power block, based on the high voltage gate drivers L6390 and power MOSFET STD5NK52ZD-1, converts the signals coming from the control block into power signals able to correctly drive the 3-phase inverter and therefore the motor.

The power supply can be fed with 110- or 230-Vac mains and the maximum allowed input power is 100 W at 230 Vacs (refer to [Chapter 7: Board architecture](#)).

In the control block, a J3 connector is mounted on both the STEVAL-IHM021V1 and STM3210B-EVAL, which allows the STM32 microcontroller's demonstration board to be used as a hardware platform for development. Minor modifications may be applied to the "STM32 FOC firmware libraries v1.0" for these to be used as a software platform for the sensorless control of your PMSM (see [Section 9.4](#)).

3 Safety and operating instructions

3.1 General

Warning: During assembly and operation, the STEVAL-IHM021V1 demonstration board poses several inherent hazards, including bare wires, moving or rotating parts and hot surfaces. Serious personal injury and damage to the property may occur if the kit or its components are used or installed incorrectly.

All operations involving transportation, installation and use, as well as maintenance, should be performed by skilled technical personnel (national accident prevention rules must be observed). *Skilled technical personnel* refers to suitably-qualified people who are familiar with the installation, use and maintenance of electronic power systems.

3.2 Intended use of the demonstration board

The STEVAL-IHM021V1 demonstration board is a component designed for demonstration purposes *only*, and must not be used for electrical installations or machinery. Technical data and information concerning the power supply conditions are detailed in the documentation and should be strictly observed.

3.3 Installing the demonstration board

The installation and cooling of the demonstration kit boards must be in accordance with the specifications and targeted application.

- The motor drive converters must be protected against excessive strain. In particular, components should not be bent or isolating distances altered during transportation or handling
- No contact must be made with other electronic components and contacts
- The boards contain electrostatically-sensitive components that are prone to damage if used incorrectly. Do not mechanically damage or destroy the electrical components (potential health risks).

3.4 Electronic connections

Applicable national accident prevention rules must be followed when working on the main power supply with a motor drive. The electrical installation must be completed in accordance with the appropriate requirements (for example, cross-sectional areas of conductors, fusing, PE connections,...).

3.5 Operating the demonstration board

A system architecture that supplies power to the STEVAL-IHM021V1 demonstration board must be equipped with additional control and protective devices in accordance with the applicable safety requirements (for example, compliance with technical equipment and accident prevention rules).

Warning: Do not touch the demonstration board after it has been disconnected from the voltage supply as several parts and power terminals containing possibly-energized capacitors need time to discharge.

4 L6390 characteristics

4.1 Main features

- High voltage rail up to 600 V
- dV/dt immunity ± 50 V/nsec in full temperature range
- Driver current capability:
 - 270-mA source
 - 430-mA sink
- Switching times 75/35 nsec RISE/FALL with 1-nF load
- 3.3-, 5-V TTL/CMOS inputs with hysteresis
- Integrated bootstrap diode
- Operational amplifier for advanced current sensing
- Comparator for fault protections
- Smart shut-down function
- Adjustable dead time
- Interlocking function.

4.2 Block diagram

Figure 3 shows the block diagram of the L6390 device.

Figure 3. L6390 block diagram

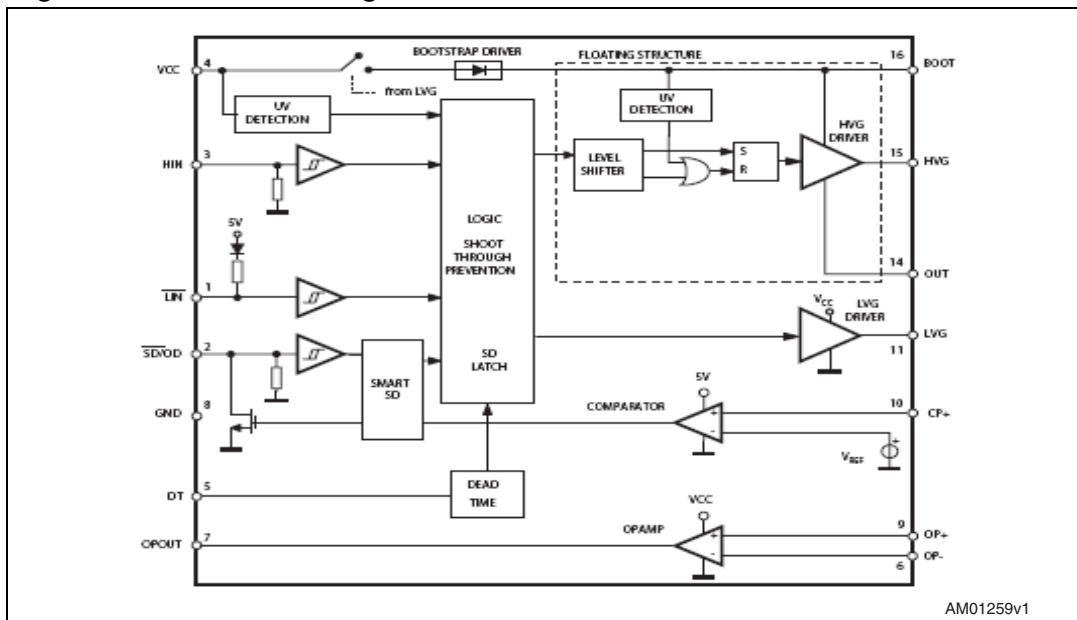

5 STD5NK52ZD-1 characteristics

The STD5NK52ZD-1 is an N-channel power MOSFET in IPAK package (520 V, 1.22 Ω, 4.4 A) Zener-protected, SuperMESH™.

Figure 4. STD5NK52ZD-1

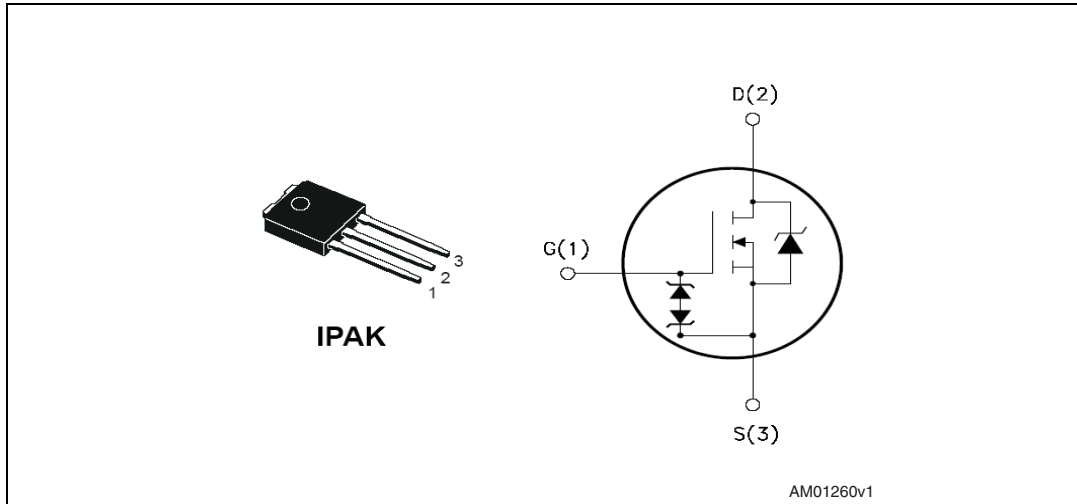

- $V_{DSS} = 520\text{ V}$
- $R_{DS(on)} < 1.5\ \Omega$
- $I_D = 4.4\text{ A}$

Table 1. STD5NK52ZD-1 absolute maximum ratings

Symbol	Parameter	Value	Unit
V_{DS}	Drain-source ($V_{GS} = 0$)	520	V
V_{DGR}	Drain-gate voltage ($R_{GS} = 20\text{ k}\Omega$)	520	V
V_{GS}	Gate-source voltage	±30	V
I_D	Drain current (continuous) at $T_C = 25^\circ\text{C}$	4.4	A
I_D	Drain current (continuous) at $T_C = 100^\circ\text{C}$	2.7	A
$I_{DM}^{(1)}$	Drain current (pulsed)	17.6	A
P_{TOT}	Total dissipation at $T_C = 25^\circ\text{C}$	70	W

1. Pulse width limited by safe operating area.

Note: Stresses above the limits shown in Table 1 may cause permanent damage to the device.

6 Electrical characteristics of the board

Stresses above the limits shown in [Table 2](#) may cause permanent damage to the devices present inside the board. These are stress ratings only and functional operation of the device under these conditions is not implied. Exposure to maximum rating conditions for extended periods may affect device reliability.

A 15-V bias current measurement may be useful to check the working status of the board. If the measured value is considerably higher than the typical value, some damage has occurred to the board. Supply the control board using a 15-V power supply connected to J10 respecting the polarity.

Table 2. Board electrical characteristics

Board parameters	STEVAL-IHM021V1		Unit
	Min	Max	
15 V auxiliary supply range – J10	14.5	17	V
15 V bias current (typical)	8	10	mA
V_{mains} – J7	30	270	Vac

Warning: To avoid damaging the board when feeding the +15-V voltage supply through the auxiliary connector (J10), remove jumper J8 and supply the +15 V *before* connecting the mains.

7 Board architecture

The STEVAL-IHM021V1 can be schematized as shown in [Figure 5](#).

Figure 5. STEVAL-IHM021V1 block diagram

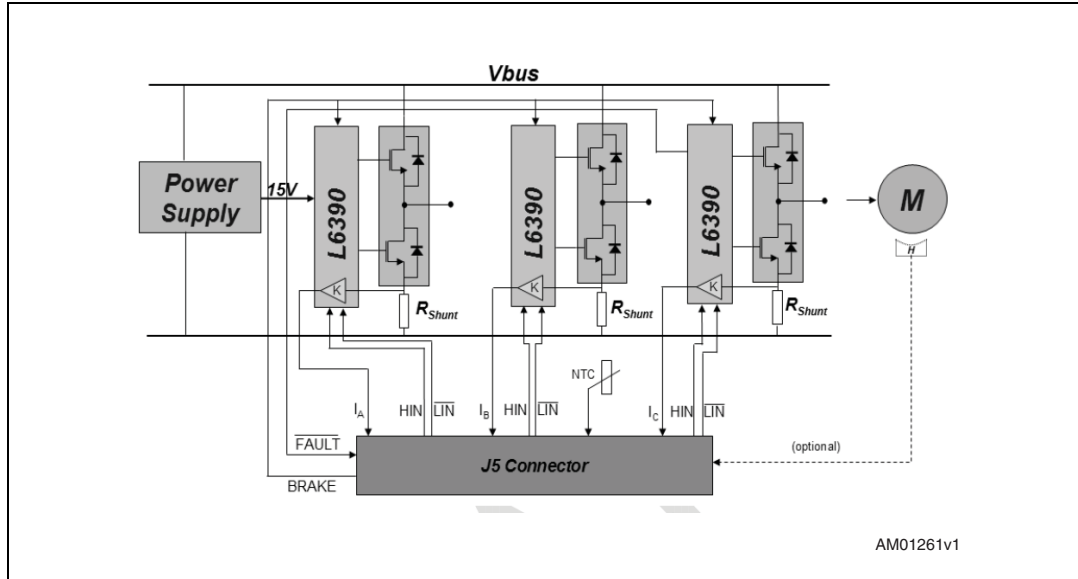

7.1 Power supply

The power supply can address the AC input voltage ranging from 30 Vac up to 270 Vac. The alternate current input is rectified by a diode bridge and a bulk capacitor to generate a direct current bus voltage approximately equal to $\sqrt{2}$ Vac (neglecting the voltage drop across the diodes and the bus voltage ripple). A VIPer12AS-E is then used in a buck converter configuration to generate the +15-V supply voltage of the gate drivers. Finally, a linear regulator (L78L33ABUTR) is used to generate the 3.3 V used to pull up the low side gate driver inputs so as to prevent the undesired turn-on of low side switches when the J5 connector is unplugged.

[Figure 6](#) shows a block diagram of the power supply.

Figure 6. Power supply block diagram

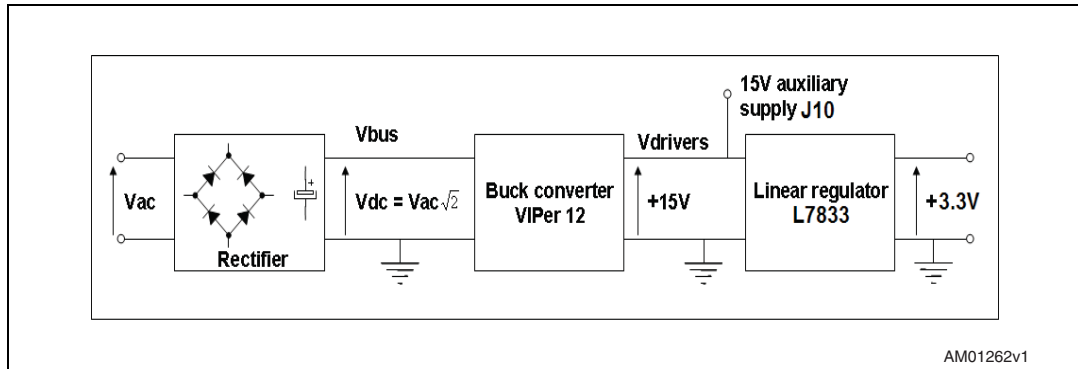

7.2 Gate driving

As mentioned previously, gate driving of the switches is performed through the latest L6390 family of devices. Refer to [Section 8.1](#) for detailed information on the gate driving circuit and dead time insertion. A fault signal is also fed back to the J5 connector if an overcurrent is detected.

7.3 Amplifying network

The voltages across the three shunt resistors are amplified by K to correctly condition the current feedback signals and optimize the output voltage range for a given phase current range and A/D converter input dynamics. Refer to [Section 8.3](#) for more detailed information on how to dimension the op-amp conditioning network depending on your needs.

7.4 Brake feature

The brake feature performs a motor brake by switching simultaneously to the low side power MOSFET, thus shortening the motor phases.

Warning: This feature is mandatory in applications that require the motor to operate in a flux-weakening region. In these conditions, the back-EMF generated by the rotor's spinning is greater than the bus voltage and the brake feature prevents the motor from acting as a generator destructively charging the bus capacitance. Refer to [Section 8.4](#) for additional information.

7.5 Temperature feedback

Temperature feedback is performed by way of an NTC. It enables you to monitor the power stage temperature so as to prevent any damage to the inverter caused by over temperature.

8 Board schematics

This section illustrates and provides an in-depth description of the board schematics.

Figure 7. Inverter schematics

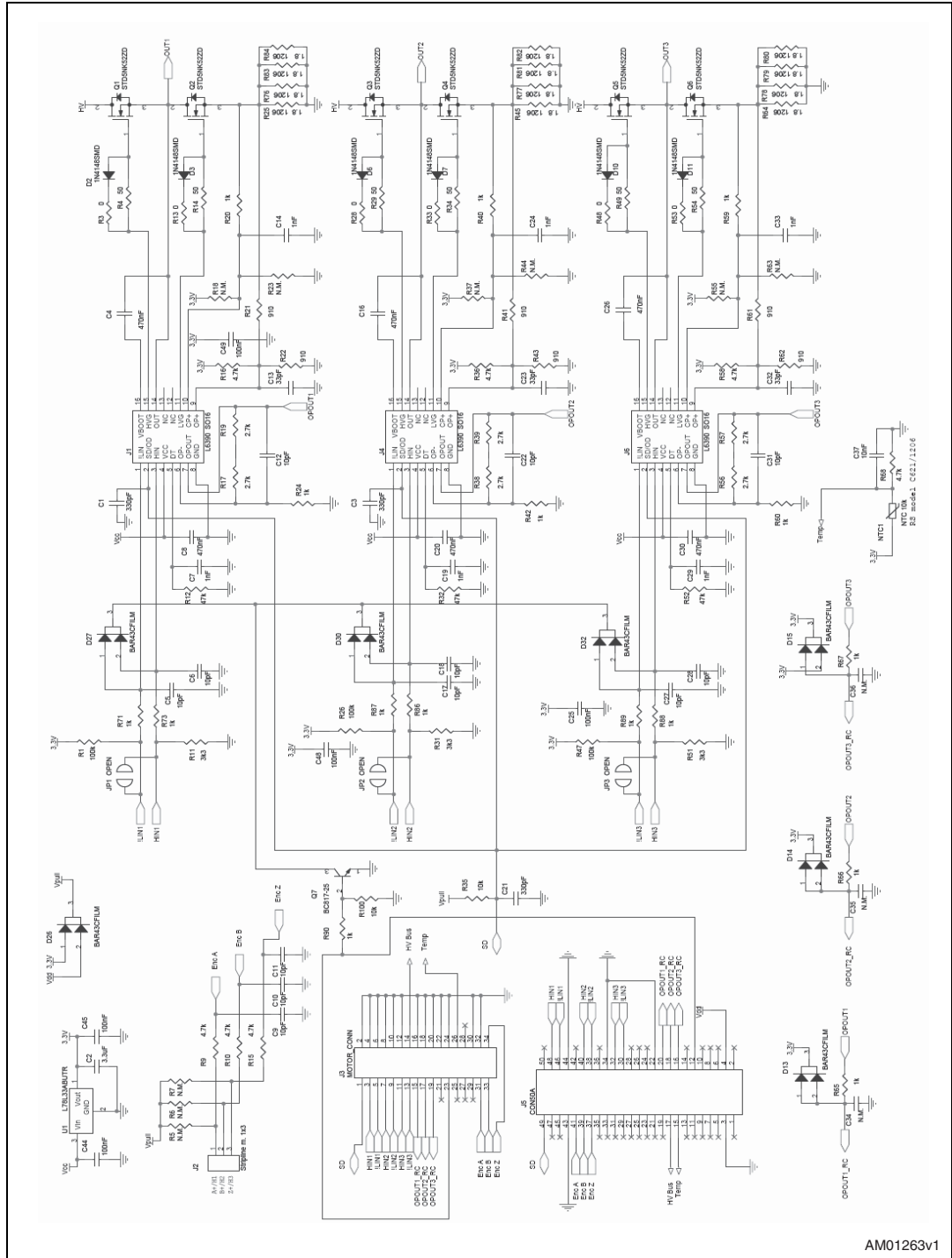

AM01263v1

Figure 8. Power supply schematics

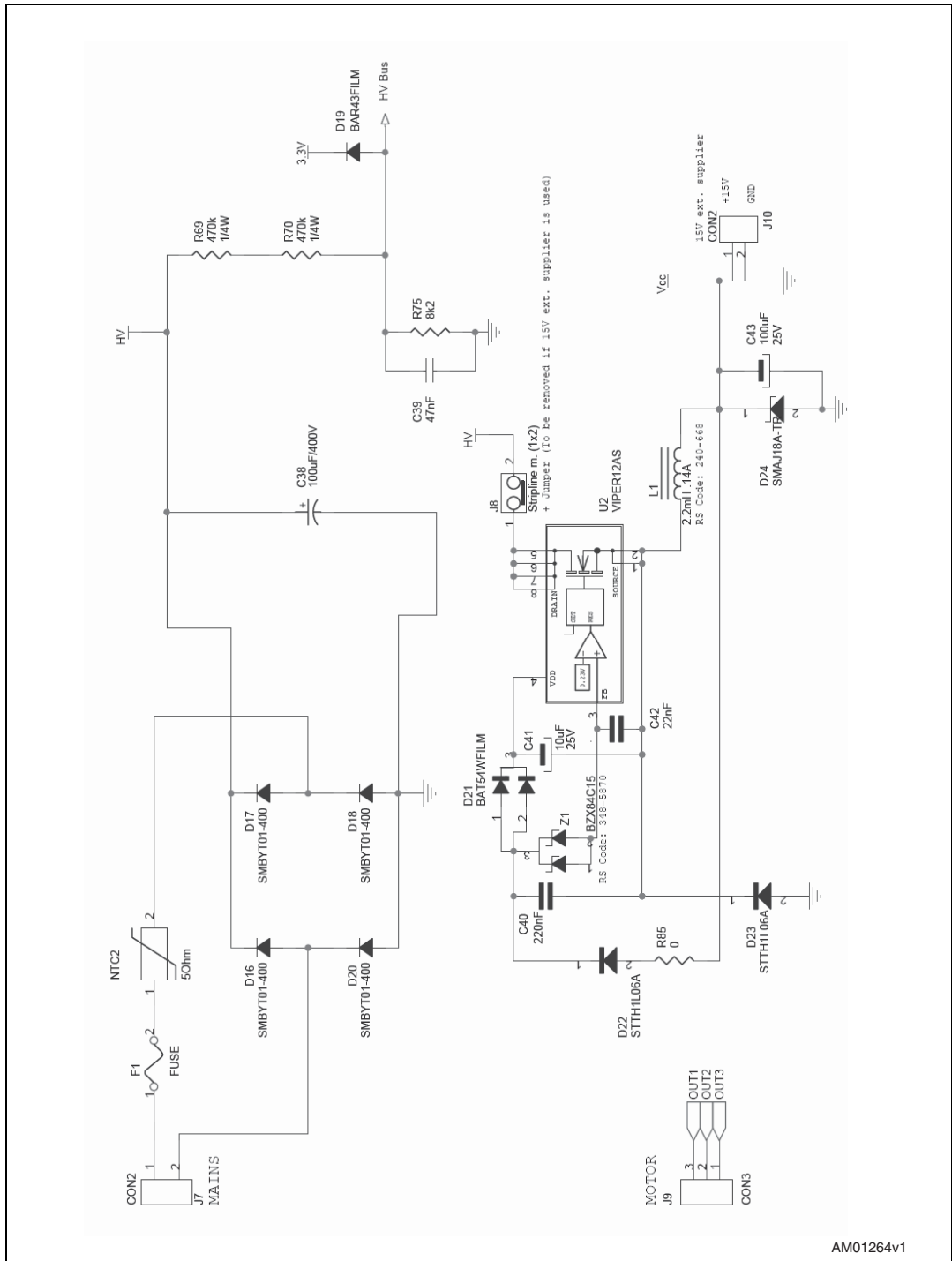

8.1 Gate driving circuit

Figure 9 shows the circuit used to turn the power MOSFETs on and off.

Figure 9. Detailed gate driving circuit

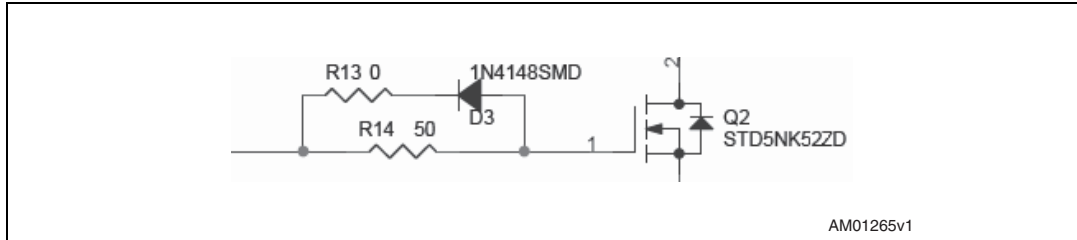

During the turn-on phase, the power MOSFET gate capacitances are charged through 50-Ω resistors while the turn-off is secured by the D3 diode (or similar).

Use of the L6390D device always guarantees a minimum adjustable dead time (DT). This dead time is applied to the HVG and LVG outputs whenever a dead time shorter than DT is present on the HIN and LIN inputs. The R12, R32 and R52 values being equal to 47 kΩ, set the minimum dead time to approximately 600 nsec.

8.2 Overcurrent protection

A hardware overcurrent protection has been implemented on the board taking advantage of the comparator integrated inside the L6390D. The internal connection between the comparator output and the shutdown block makes the intervention time of the overcurrent protection extremely low, slightly above 100 nsec.

Figure 10. Overcurrent protection

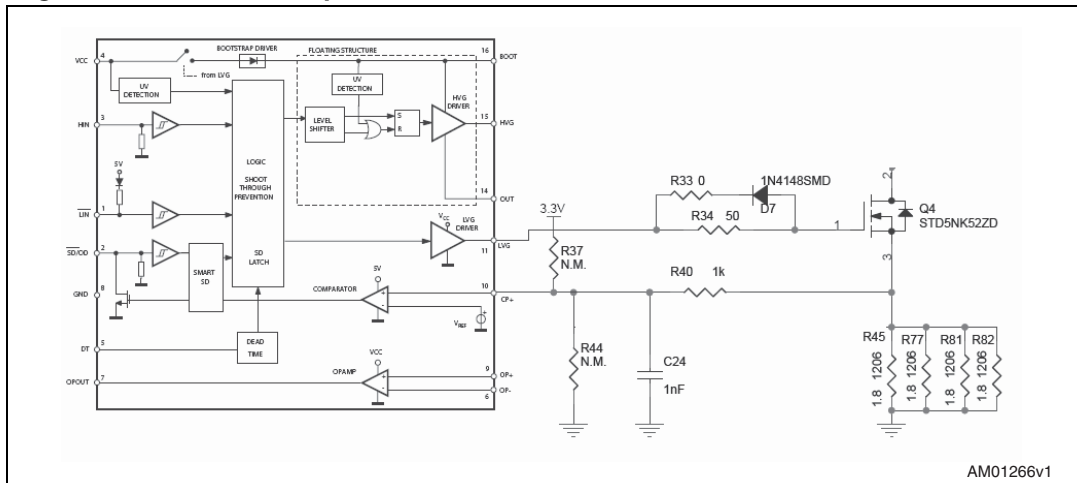

Since the overcurrent protection acts as soon as the voltage on CP+ rises above Vref (approximately equal to 0.53 V), and given the default value of the shunt resistors (equal to 1.8/4 =0.45 Ω), it follows that the default value for the maximum allowed current (ICP) is equal to:

Equation 1

$$I_{CP} = \frac{V_{Ref}}{R_{shunt}} \cong 1.15 \text{ A}$$

If necessary, you can decrease the threshold by adding R37 (and similarly R55 and R18) with the formula:

Equation 2

$$I_{CP} = \frac{1}{R_{shunt}} \cdot \frac{R40 + R37}{R37} \left[V_{ref} - 3.3 \frac{R40}{R37 + R40} \right] \quad \text{with } R37 \gg R40$$

Similarly, you can increase the threshold by adding R44 (and similar) with the formula:

Equation 3

$$I_{CP} = \frac{V_{ref}}{R_{shunt}} \cdot \left(1 + \frac{R40}{R44} \right) \quad \text{with } R37 \gg R40$$

8.3 Current sensing amplifying network

Figure 11 shows the current sensing amplifying network during phase 2.

Figure 11. Current sensing amplifying network

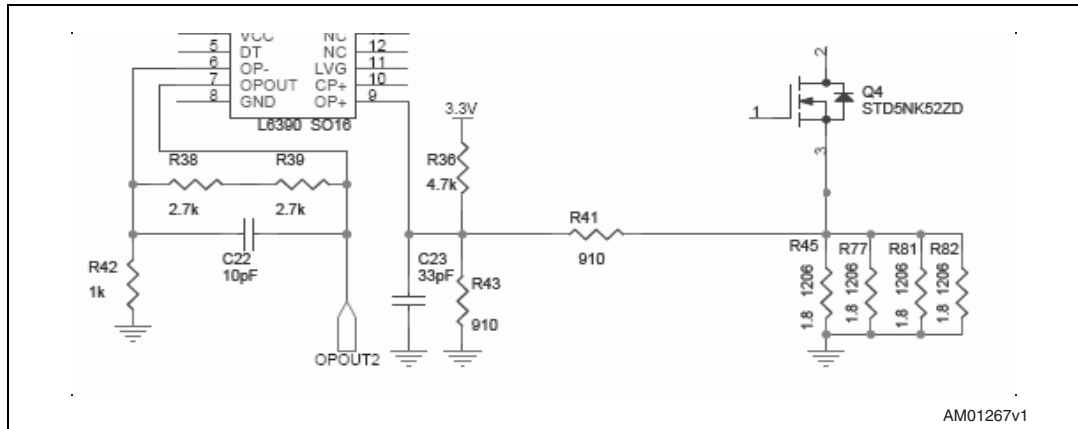

The voltage at node "OPOUT2" can be computed as the sum of a bias and a signal component, respectively equal to:

Equation 4

$$V_{\text{BIAS}} = 3.3 \frac{R41//R43}{R36 + R41//R43} \left(1 + \frac{R38 + R39}{R42} \right)$$

Equation 5

$$V_{\text{SIGN}} = I \cdot R_{\text{SHUNT}} \cdot \frac{R36//R43}{R41 + R36//R43} \left(1 + \frac{R38 + R39}{R42} \right)$$

With the default values this gives:

- $V_{\text{BIAS}} = 1.86 \text{ V}$
- $V_{\text{SIGN}} = 2.91 \cdot R_{\text{SHUNT}} \cdot I$

As such, the maximum current amplifiable without distortion is equal to:

Equation 6

$$I_{\text{MAX}} = \frac{3.3 - 1.86}{2.91 \cdot R_{\text{SHUNT}}} = \frac{0.495}{R_{\text{SHUNT}}} = 1.1 \text{ A}$$

Note that you could modify the I_{MAX} value by simply changing the values of the shunt resistors.

8.4 Brake function

The STEVAL-IHM021V1 board provides a brake function that through the pull-up of a single brake signal simultaneously turns the three low side switches *ON*, shorting the 3-phase load. The feature is accessed using one single small-signal bipolar transistor (Q7), whose function is to pull down the cathodes of six small signal diodes connected to each of the six logic inputs (HIN1, $\overline{\text{LIN}} 1$, HIN2, $\overline{\text{LIN}} 2$, HIN3, $\overline{\text{LIN}} 3$) of the L6390 gate drivers. The in-series resistors together with the input lines avoid any conflict with the external controller input signals, giving priority to the brake signal (see [Figure 12](#)).

Figure 12. Brake circuit

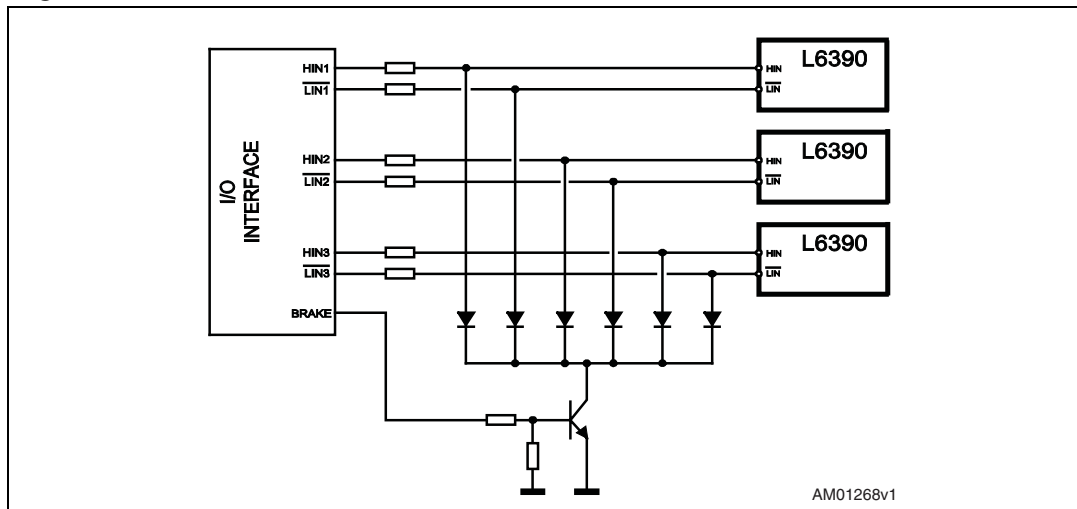

The brake signal is active high and 3.3-/5-V-compatible.

Table 3. Truth table

HINx	$\overline{\text{LIN}}\text{ x}$	$\overline{\text{SD}}$	Brake	LVGx	HVGx	Load
x	x	0	x	0	0	Tri-state
x	x	1	1	1	0	brake
0	0	1	0	1	0	Normal operation
0	1	1	0	0	0	
1	0	1	0	0	0	
1	1	1	0	0	1	

Warning: This feature is mandatory in applications that require the motor to operate in the flux-weakening region. In these conditions, the back-EMF generated by the rotor spinning is greater than the bus voltage and the brake feature prevents the motor from acting as a generator destructively charging the bus capacitance.

9 Using the STEVAL-IHM021V1 with the STM32 FOC firmware library

The "*STM32 FOC firmware library v2.0*" runs on the STM3210B-MCKIT and does the field-oriented control (FOC) of a permanent magnet synchronous motor (PMSM) in both sensor and sensorless configurations.

This section describes the modifications to be applied to the "*STM32 FOC firmware library v2.0*" in order for the firmware to be compatible with the STEVAL-IHM021V1.

9.1 Environmental considerations

Warning: The STEVAL-IHM021V1 demonstration board must only be used in a power laboratory. The voltage used in the drive system presents a shock hazard.

The kit is not electrically isolated from the DC input. This topology is very common in motor drives. The microprocessor is grounded by the integrated ground of the DC bus. The microprocessor and associated circuitry are hot and MUST be isolated from user controls and communication interfaces.

Warning: Any measurement equipment must be isolated from the main power supply before powering up the motor drive. To use an oscilloscope with the kit, it is safer to isolate the DC supply AND the oscilloscope. This prevents a shock from occurring as a result of touching any single point in the circuit, but does NOT prevent shocks when touching two or more points in the circuit.

An isolated AC power supply can be constructed using an isolation transformer and a variable transformer. A schematic of this AC power supply is shown in the application note "*AN438, TRIAC + Microcontroller: safety precautions for development tools*". Although this application note was written for TRIAC, the isolation constraints still apply for switching semiconductor devices such as MOSFETs.

Note: Isolating the application rather than the oscilloscope is highly recommended in any case.

9.2 Hardware requirements

The following items are required to run the STEVAL-IHM021V1 together with the "STM32 FOC firmware library".

- The STEVAL-IHM021V1 board and MB525 board (STM32 evaluation board with MC connector).
- A high-voltage insulated AC power supply up to 230 Vac.
- A J-link programmer (not included in the package).
- A J-link insulating board (not included in the package).
- A 3-phase brushless motor with permanent magnet rotor (not included in the package).
- An insulated oscilloscope (as necessary).
- An insulated multimeter (as necessary).

9.3 Software requirements

To customize, compile and download the "STM32 FOC firmware library v2.0" motor control firmware, the IAR tool "EWARM v5.20 (or v5.11)" must be installed. The free 32-k limited version (referenced as the "KickStart" version) is available for downloading at: <http://supp.iar.com/Download/SW/?item=EWARM-KS32-442A>.

9.4 Software modifications

The "STM32 FOC firmware library v2.0" is compatible with the L6386 high-side driver. To make the firmware compatible with the L6390, you must change the polarity of the PWM driving the low-side transistors.

To do so, Follow these steps.

1. In "*stm32f10x_svpwm_3shunt.c*" substitute line 177 with:

```
TIM1_OCInitStructure.TIM_OCNPolarity = TIM_OCNPolarity_Low;
```
2. In "*stm32f10x_svpwm_3shunt.c*" substitute line 88 with:

```
#define IDLE_LOW_SIDE_POLARITY_L6390          TIM_OCIdleState_Set
#define LOW_SIDE_POLARITY                    IDLE_LOW_SIDE_POLARITY_L6390
```
3. In "*MC_MotorControl_Layer.c*" substitute lines 49 and 50 with:

```
#define NTC_THRESHOLD (u16) ((225 * (NTC_THRESHOLD_C - 25)) + 10477)
#define NTC_HYSTERIS (u16) ((225 * (NTC_THRESHOLD_C - NTC_HYSTERIS_C - 25)) + 10477)
```
4. In "*MC_MotorControl_Layer.c*" substitute line 382 with:

```
return ((u8)(((s16)w_Temp_Average - 10477)/225 + 25));
```
5. In "*MC_Control_Param.h*" set the required temperature threshold and hysteresis with:

```
#define NTC_THRESHOLD_C    60 // (°C)
#define NTC_HYSTERIS_C    5 // Temperature hysteresis (°C)
```

10 References

This user manual provides information on the hardware features and use of the STEVAL-IHM021V1 demonstration board. For additional information on supporting software and tools, refer to the following:

- STD5NK52ZD-1 datasheet
- L6390 datasheet
- <http://www.st.com/mcu/> web site, which is dedicated to the complete STMicroelectronics microcontroller portfolio.

11 Revision history

Table 4. Document revision history

Date	Revision	Changes
29-Sep-2008	1	Initial release.

Please Read Carefully:

Information in this document is provided solely in connection with ST products. STMicroelectronics NV and its subsidiaries ("ST") reserve the right to make changes, corrections, modifications or improvements, to this document, and the products and services described herein at any time, without notice.

All ST products are sold pursuant to ST's terms and conditions of sale.

Purchasers are solely responsible for the choice, selection and use of the ST products and services described herein, and ST assumes no liability whatsoever relating to the choice, selection or use of the ST products and services described herein.

No license, express or implied, by estoppel or otherwise, to any intellectual property rights is granted under this document. If any part of this document refers to any third party products or services it shall not be deemed a license grant by ST for the use of such third party products or services, or any intellectual property contained therein or considered as a warranty covering the use in any manner whatsoever of such third party products or services or any intellectual property contained therein.

UNLESS OTHERWISE SET FORTH IN ST'S TERMS AND CONDITIONS OF SALE ST DISCLAIMS ANY EXPRESS OR IMPLIED WARRANTY WITH RESPECT TO THE USE AND/OR SALE OF ST PRODUCTS INCLUDING WITHOUT LIMITATION IMPLIED WARRANTIES OF MERCHANTABILITY, FITNESS FOR A PARTICULAR PURPOSE (AND THEIR EQUIVALENTS UNDER THE LAWS OF ANY JURISDICTION), OR INFRINGEMENT OF ANY PATENT, COPYRIGHT OR OTHER INTELLECTUAL PROPERTY RIGHT.

UNLESS EXPRESSLY APPROVED IN WRITING BY AN AUTHORIZED ST REPRESENTATIVE, ST PRODUCTS ARE NOT RECOMMENDED, AUTHORIZED OR WARRANTED FOR USE IN MILITARY, AIR CRAFT, SPACE, LIFE SAVING, OR LIFE SUSTAINING APPLICATIONS, NOR IN PRODUCTS OR SYSTEMS WHERE FAILURE OR MALFUNCTION MAY RESULT IN PERSONAL INJURY, DEATH, OR SEVERE PROPERTY OR ENVIRONMENTAL DAMAGE. ST PRODUCTS WHICH ARE NOT SPECIFIED AS "AUTOMOTIVE GRADE" MAY ONLY BE USED IN AUTOMOTIVE APPLICATIONS AT USER'S OWN RISK.

Resale of ST products with provisions different from the statements and/or technical features set forth in this document shall immediately void any warranty granted by ST for the ST product or service described herein and shall not create or extend in any manner whatsoever, any liability of ST.

ST and the ST logo are trademarks or registered trademarks of ST in various countries.

Information in this document supersedes and replaces all information previously supplied.

The ST logo is a registered trademark of STMicroelectronics. All other names are the property of their respective owners.

© 2008 STMicroelectronics - All rights reserved

STMicroelectronics group of companies

Australia - Belgium - Brazil - Canada - China - Czech Republic - Finland - France - Germany - Hong Kong - India - Israel - Italy - Japan - Malaysia - Malta - Morocco - Singapore - Spain - Sweden - Switzerland - United Kingdom - United States of America

www.st.com