

© 1964 BY AMP INCORPORATED. ALL RIGHTS RESERVED. AMP PRODUCTS COVERED BY PATENTS AND/OR PATENTS PENDING. APPROVED PER GOVT CONTRACT NO.

REVISIONS				
SYM	ZONE	DESCRIPTION	DATE	APPROVAL
0		RELEASED WAS M5001-679	7/16/64	KJ D.S.H.
A		REVISED W-276	5-27-65	M.S./D.H.
B		REMOVE PROPOSED DESIGN STAMP W-530	7-23-65	M.S. RM
C		REVISED Y-68	1-18-66	M.S. J.H.
D		ADDED "A" DIMEN & -2 ECN A-881	11/3/70	MD SJS
D1		REV. PER ECN D-644	8 9-17-75	JL
E		REV PER ECU-05-001412	AA 05/05	DL
F		REV PER ECO-05-005359	11/65	PY/DE
G		ECO-09-002648	PY 5-09	DE

SUPERSEDED BY 5-202567-1 202567-1 1. AS SHOWN.  
 2. "A" DIMENSION = .891

**OBSOLETE** 202567-2 1. SAME AS -1 EXCEPT:  
 2. "A" DIMENSION = 1.266

5-202567-1 1. SAME AS -1 EXCEPT:  
 2. PLATED ELECTROLESS NICKEL PER SAE-AMS-C.26074  
 .000400-.000800 THK (NO INTENTIONAL ADDITIONS  
 OF LEAD OR CHROMIUM PER AFE STD 230-700).  
 3. "A" DIMENSION = .891

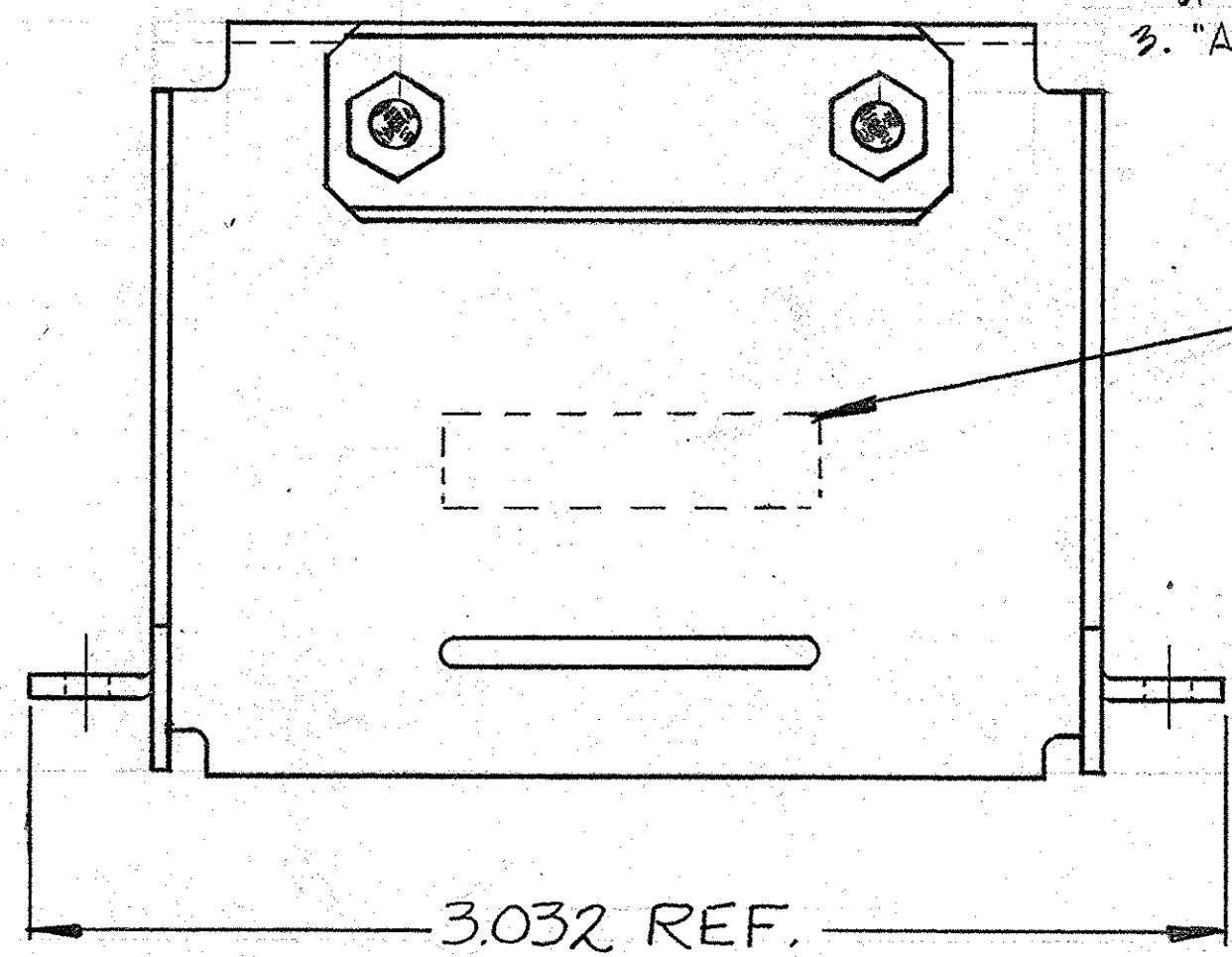
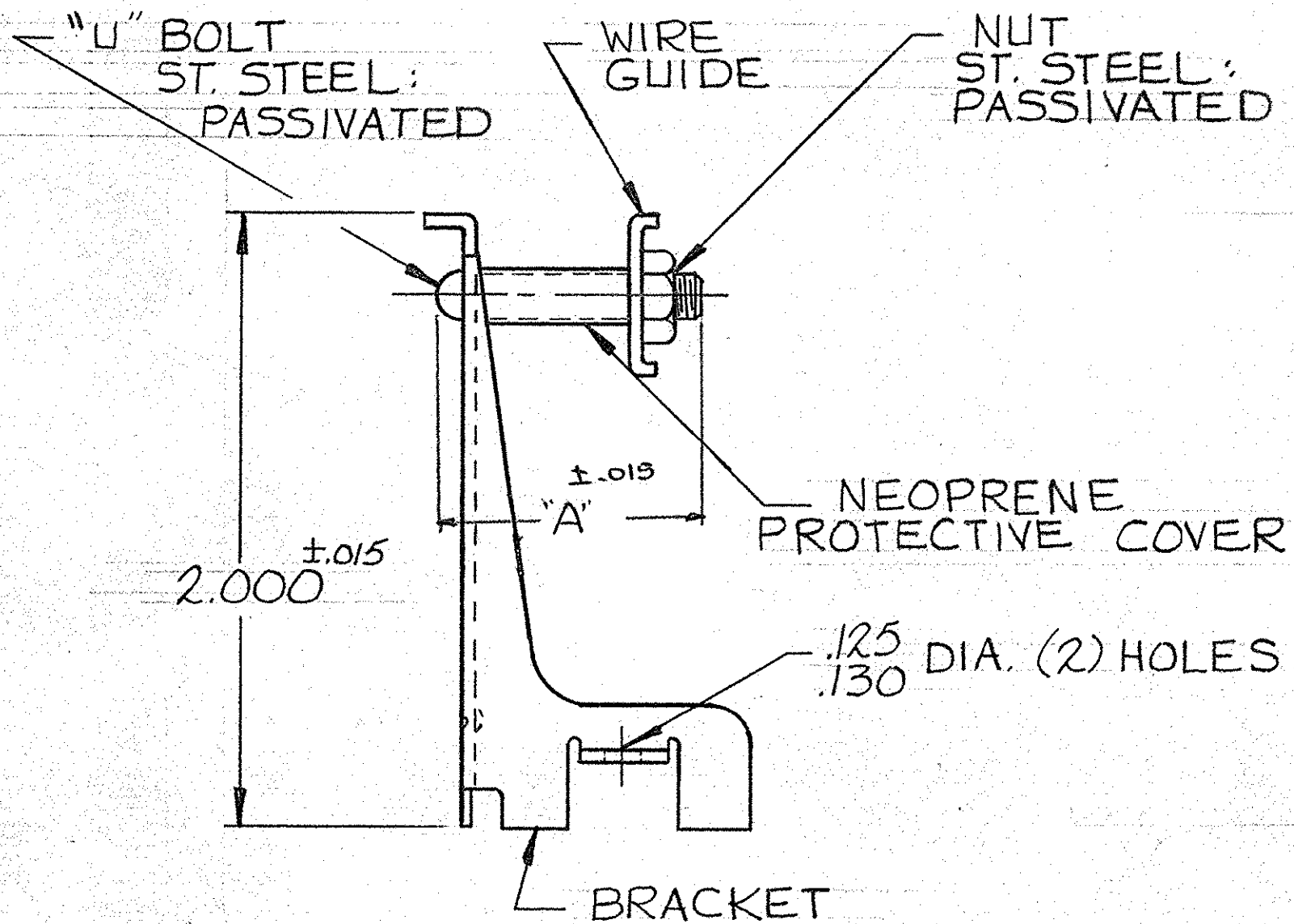

INK STAMP  
 "AMP" & ASS'Y. NO.  
 & DATE CODE IN  
 THIS AREA ON  
 OPPOSITE SIDE,

NOTE:  
 © 1. ZINC PLATE PER ASTM-B-633 CLASS 3 TYPE II.  
 COLORLESS SUPPLEMENTARY CHROMATE.

AMP INFO		NOMENCLATURE OR DESCRIPTION		PART OR IDENTIFYING NO.	
LOC	PRINT DIST	LIST OF MATERIALS OR PARTS LIST			
A	39	UNLESS OTHERWISE SPECIFIED DIMENSIONS ARE IN INCHES TOLERANCES ON FRACTIONS DECIMALS ANGLES ± .005 ±		SIGNATURE DATE	
MATERIAL		HEAT TREAT		AMP INCORPORATED HARRISBURG, PENNSYLVANIA	
C. R. STEEL		— / —		STRAIN RELIEF CLAMP ASS'Y. FOR (3) BLOCK SERIES "G" ASSEMBLY	
FINISH		OTHER APPD		CODE IDENT NO. SIZE NUMBER	
SEE NOTE 1				00779 C 202567	
				REV G	
				SCALE 2-1 WT CALC ACTUAL SHEET	