

**PART NUMBER CODING**

C S N - M

**MATERIAL (INSULATOR / CONTACT)**  
(SEE MATERIAL TABLE)

**PLATING**

ALL PLATINGS HAVE .000050" MIN NICKEL UNDERPLATE

CONTACT SURFACE	TERMINATION
B = .00010" GOLD	.000100" PURE TIN, MATTE
C = .00030" GOLD	.000100" PURE TIN, MATTE
G = .00010" GOLD	.000005" GOLD
E = .000100" PURE TIN, MATTE	
S = .00010" GOLD OVERALL	
M = .00030" GOLD	.000010" GOLD OVERALL

**MODIFICATION**

OMIT = STANDARD, EXAMPLE: 'AMC22SAAN'  
M500 = BROWN PPS (MATERIAL CODES 'A' AND 'R' ONLY)

**TERMINATION TYPE**

**NUMBER OF POSITIONS PER ROW**

(01 THRU 36)

**MATERIAL TABLE**

LETTER CODE	INSULATOR / CONTACT	OPERATING TEMP.	PROCESSING TEMP.	MODIFICATION NUMBER
P	BLACK PBT / PHOSPHOR BRONZE	-65°C TO +125°C	WAVE/MANUAL SOLDERING	OMIT
G	BLACK PA9T / PHOSPHOR BRONZE	-65°C TO +150°C	260°C MAX FOR 10 SECONDS	OMIT
L	WHITE PA9T / PHOSPHOR BRONZE	-65°C TO +150°C	260°C MAX FOR 10 SECONDS	OMIT
R	GREEN PPS / PHOSPHOR BRONZE	-65°C TO +175°C	260°C MAX FOR 20 SECONDS	OMIT
R	BROWN PPS / PHOSPHOR BRONZE	-65°C TO +175°C	260°C MAX FOR 20 SECONDS	M500
*A	GREEN PPS / BERYLLIUM COPPER	-65°C TO +200°C	260°C MAX FOR 20 SECONDS	OMIT
*A	BROWN PPS / BERYLLIUM COPPER	-65°C TO +200°C	260°C MAX FOR 20 SECONDS	M500
*Y	TAN PEEK / BERYLLIUM COPPER	-65°C TO +250°C	260°C MAX FOR 20 SECONDS	OMIT

\* AVAILABLE WITH OVERALL GOLD PLATING ('M') ONLY

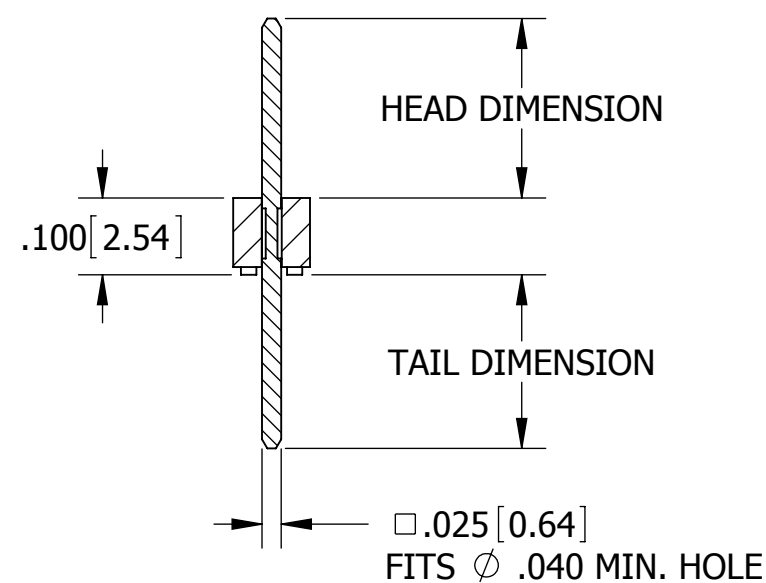
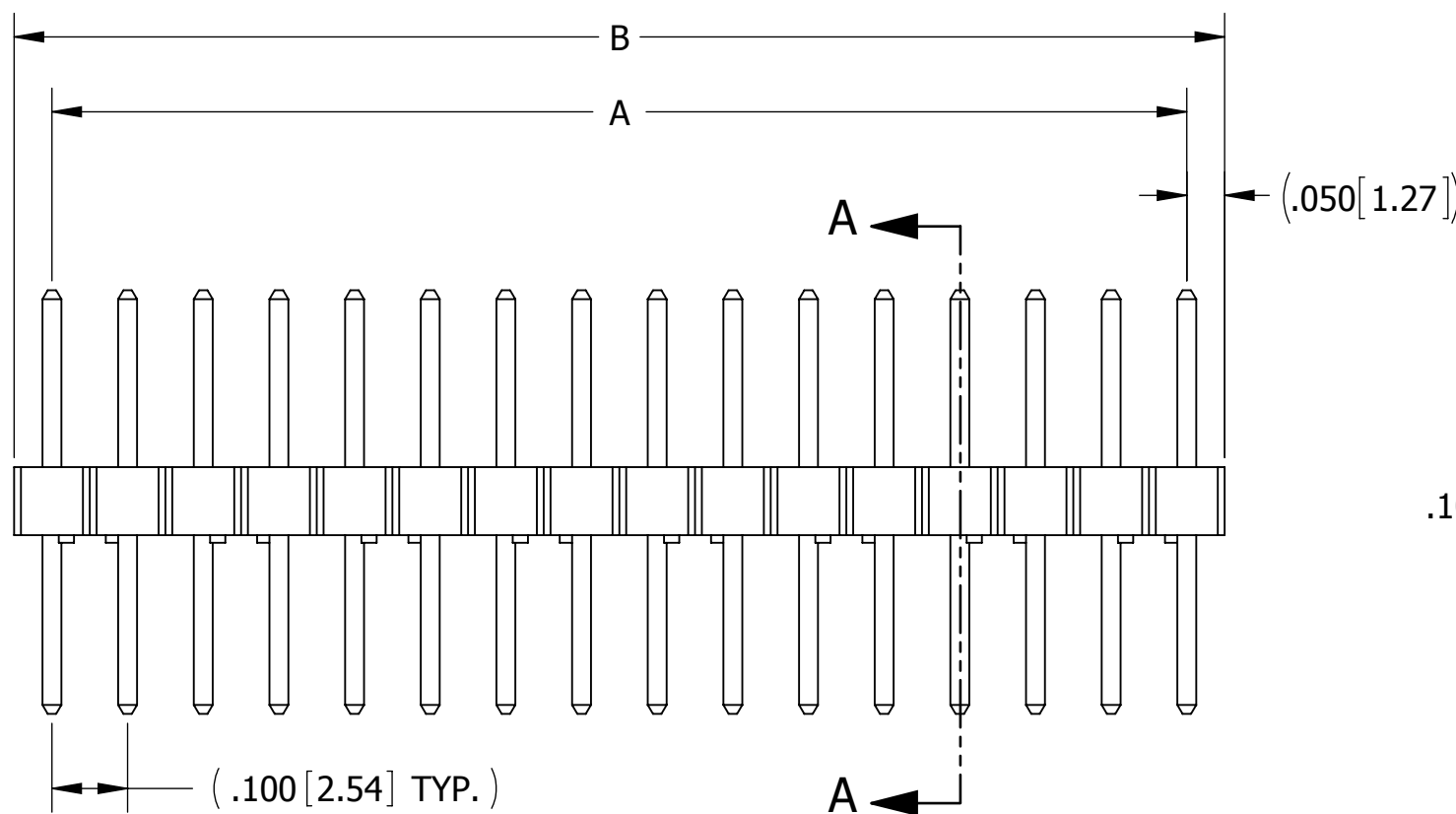
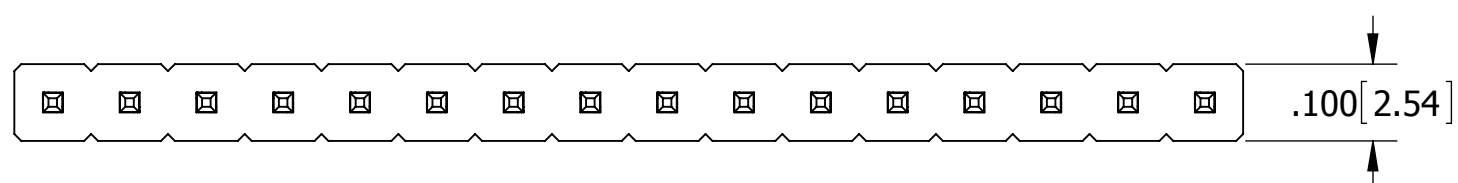

**SECTION A-A**

**NOTES:**

- INSULATOR MATERIAL: SEE PART NUMBER CODING
- CONTACT MATERIAL: SEE PART NUMBER CODING
- PLATING: SEE PART NUMBER CODING
- UL FLAMMABILITY RATING: 94V-0
- DIELECTRIC WITHSTANDING VOLTAGE: 1800 VAC
- CURRENT RATING: 3 AMPS
- CONTACT RESISTANCE: 30 MILLIOHMS MAX.
- INSULATION RESISTANCE: 5000 MEGOHMS MIN.



RoHS COMPLIANT

REVISIONS				
REV.	ECO. NO	DESCRIPTION	DATE	BY
E	2763	ADDED 'G' PLATING & UPDATED OPERATING TEMPERATURE FOR 'R' MATERIAL	4/17/2013	KV
F	2855	CHANGED DEFAULT PPS FROM BLACK COLOR TO GREEN COLOR, REMOVED 'R' MATERIAL OPTION (OFFERED 'A' ONLY FOR 200C APPLICATION), ADD 'Y' & 'L' MATERIAL / COLOR OPTION	2/25/2014	JH
G	2995	ADD 'R' MATERIAL OPTION FOR 175 C APPLICATION	6/11/2014	JH
H	3134	UPDATE BOM FOR P MATERIAL CODE	1/14/2015	JHSU

TERMINATION TYPE			A		B	
CODE	HEAD DIMENSION	TAIL DIMENSION	INCH	MM	INCH	MM
			±.008	±0.20	±.020	±0.51
AA	.230[5.84]	.120[3.05]				
AB	.230[5.84]	.230[5.84]				
AC	.230[5.84]	.320[8.13]				
AD	.230[5.84]	.420[10.67]				
AE	.230[5.84]	.520[13.21]				
AF	.230[5.84]	.620[15.75]				
AG	.230[5.84]	.720[18.29]				
AH	.230[5.84]	.820[20.83]				
AI	.230[5.84]	.900[22.86]				
AJ	.230[5.84]	1.000[25.40]				
AK	.230[5.84]	.035[0.89]				
FA	.318[8.08]	.120[3.05]				
FB	.318[8.08]	.220[5.59]				
FC	.318[8.08]	.320[8.13]				
FD	.318[8.08]	.420[10.67]				
FE	.318[8.08]	.520[13.21]				
FF	.318[8.08]	.620[15.75]				
FG	.318[8.08]	.710[18.03]				
FH	.318[8.08]	.810[20.57]				
FI	.318[8.08]	.910[23.11]				
FJ	.318[8.08]	.050[1.27]				
ZA	.120[3.05]	.120[3.05]				
ZB	.120[3.05]	.095[2.41]				
ZC	.120[3.05]	.260[6.60]				
ZD	.120[3.05]	.610[15.49]				
ZI	.520[13.21]	.110[2.79]				
ZJ	.720[18.29]	.110[2.79]				
ZO	.820[20.83]	.110[2.79]				
ZQ	1.020[25.91]	.110[2.79]				
ZR	1.220[30.99]	.110[2.79]				
__C01S__N	0.000	0.00	0.100	2.54		
__C02S__N	0.100	2.54	0.200	5.08		
__C03S__N	0.200	5.08	0.300	7.62		
__C04S__N	0.300	7.62	0.400	10.16		
__C05S__N	0.400	10.16	0.500	12.70		
__C06S__N	0.500	12.70	0.600	15.24		
__C07S__N	0.600	15.24	0.700	17.78		
__C08S__N	0.700	17.78	0.800	20.32		
__C09S__N	0.800	20.32	0.900	22.86		
__C10S__N	0.900	22.86	1.000	25.40		
__C11S__N	1.000	25.40	1.100	27.94		
__C12S__N	1.100	27.94	1.200	30.48		
__C13S__N	1.200	30.48	1.300	33.02		
__C14S__N	1.300	33.02	1.400	35.56		
__C15S__N	1.400	35.56	1.500	38.10		
__C16S__N	1.500	38.10	1.600	40.64		
__C17S__N	1.600	40.64	1.700	43.18		
__C18S__N	1.700	43.18	1.800	45.72		
__C19S__N	1.800	45.72	1.900	48.26		
__C20S__N	1.900	48.26	2.000	50.80		
__C21S__N	2.000	50.80	2.100	53.34		
__C22S__N	2.100	53.34	2.200	55.88		
__C23S__N	2.200	55.88	2.300	58.42		
__C24S__N	2.300	58.42	2.400	60.96		
__C25S__N	2.400	60.96	2.500	63.50		
__C26S__N	2.500	63.50	2.600	66.04		
__C27S__N	2.600	66.04	2.700	68.58		
__C28S__N	2.700	68.58	2.800	71.12		
__C29S__N	2.800	71.12	2.900	73.66		
__C30S__N	2.900	73.66	3.000	76.20		
__C31S__N	3.000	76.20	3.100	78.74		
__C32S__N	3.100	78.74	3.200	81.28		
__C33S__N	3.200	81.28	3.300	83.82		
__C34S__N	3.300	83.82	3.400	86.36		
__C35S__N	3.400	86.36	3.500	88.90		
__C36S__N	3.500	88.90	3.600	91.44		

**CUSTOMER COPY**

UNLESS OTHERWISE SPECIFIED: DIMENSIONS ARE IN INCHES [MM]	DRAWN	DATE	NAME	
		9/9/2011	JH	
TOLERANCES: ANGULAR: ± 1° DECIMALS .XX = ± .02 [ .5] .XXX = ± .005 [ .13] .XXXX = ± .0005 [ .013]	THE INFORMATION HEREIN CONTAINS PROPRIETARY INFORMATION OF SULLINS ELECTRONICS AND IS NOT TO BE REPRODUCED, USED OR DISCLOSED TO OTHERS FOR ANY PURPOSE EXCEPT AS SPECIFICALLY AUTHORIZED IN WRITING BY AN OFFICER OF SULLINS ELECTRONICS.			TITLE
				.100" CC, HEADER, STRAIGHT
PART NUMBER				REV
__C__S__N - (M500)				H
SIZE	CAGE CODE	DWG. NO.		
C	54453	C10436		
SCALE: 4:1			SHEET 1 OF 1	