

THIS DRAWING IS UNPUBLISHED. RELEASED FOR PUBLICATION 19
 COPYRIGHT IS BY AMP INCORPORATED, HARRISBURG, PA. ALL INTERNATIONAL RIGHTS RESERVED. AMP PRODUCTS MAY BE COVERED BY U.S. AND FOREIGN PATENTS AND/OR PATENTS PENDING.

		REVISIONS		DATE	APPROVED
0	O	RELEASE DRAWING PER TTI-83-133		11/28/83	[Signature]
1	O	RESTORED		1/14/85	[Signature]
2	A	REV PER EGN CM 705		7/1/85	[Signature]

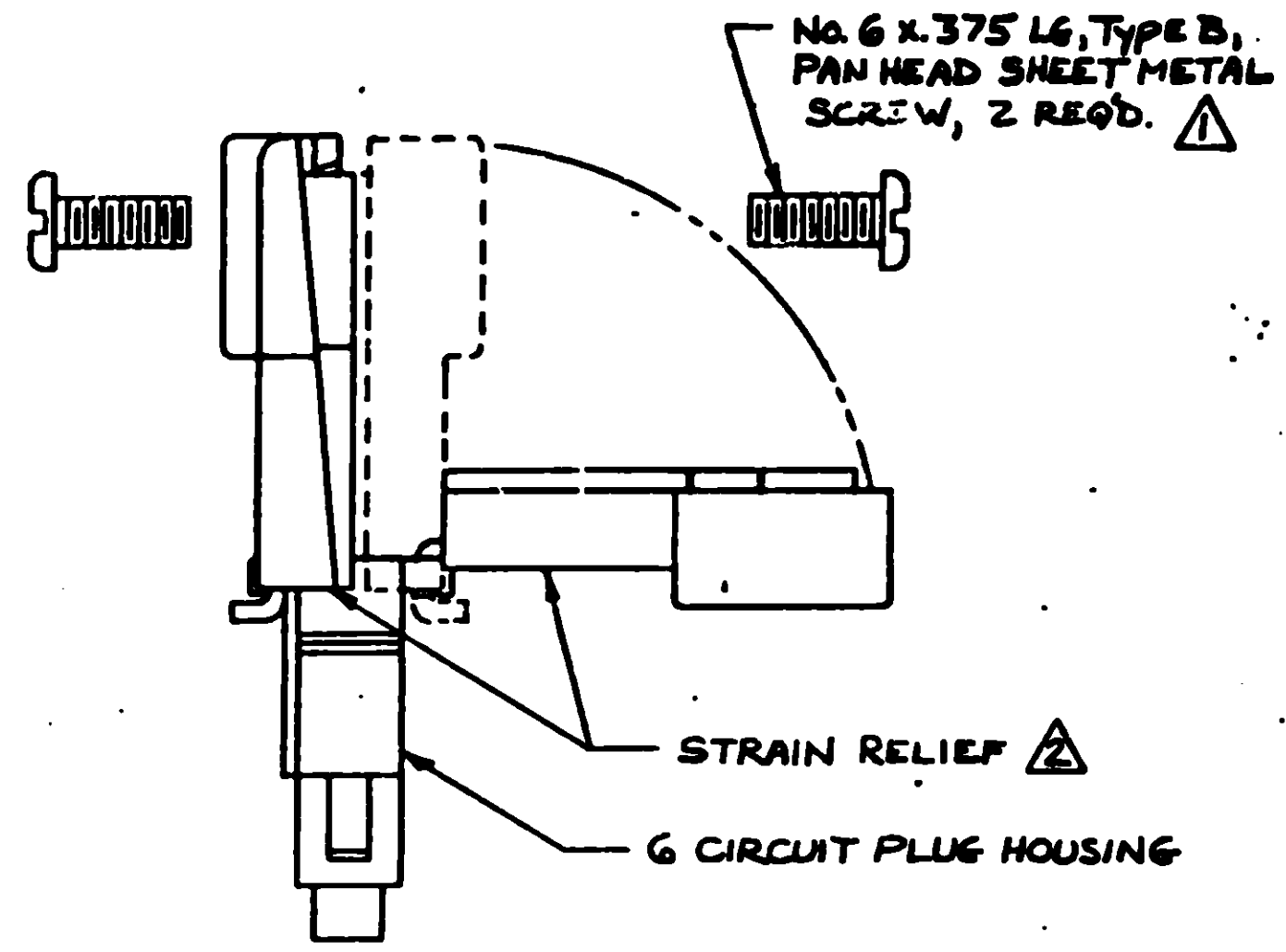
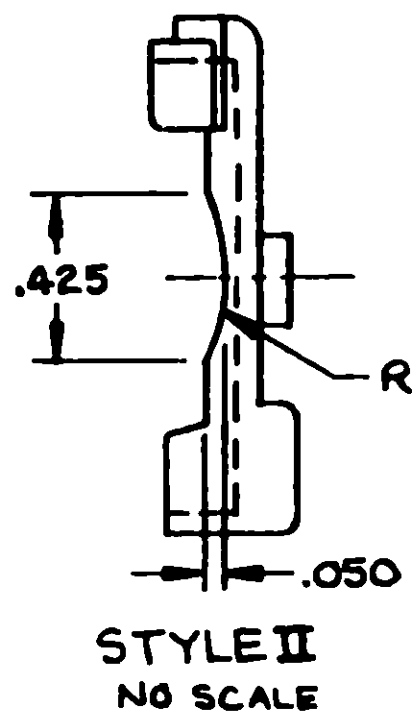
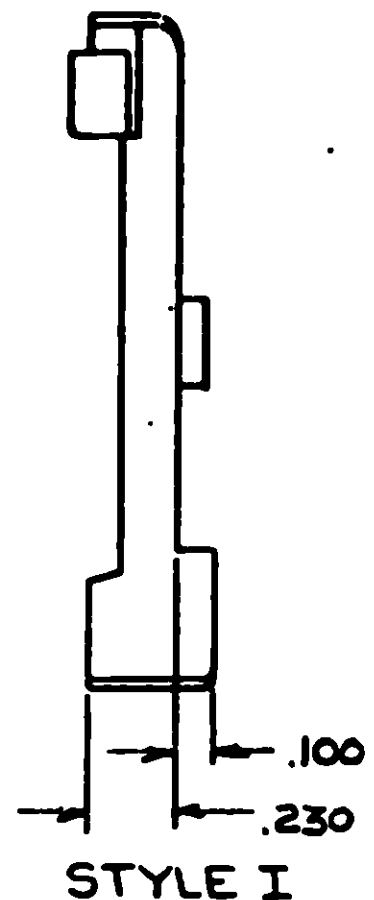
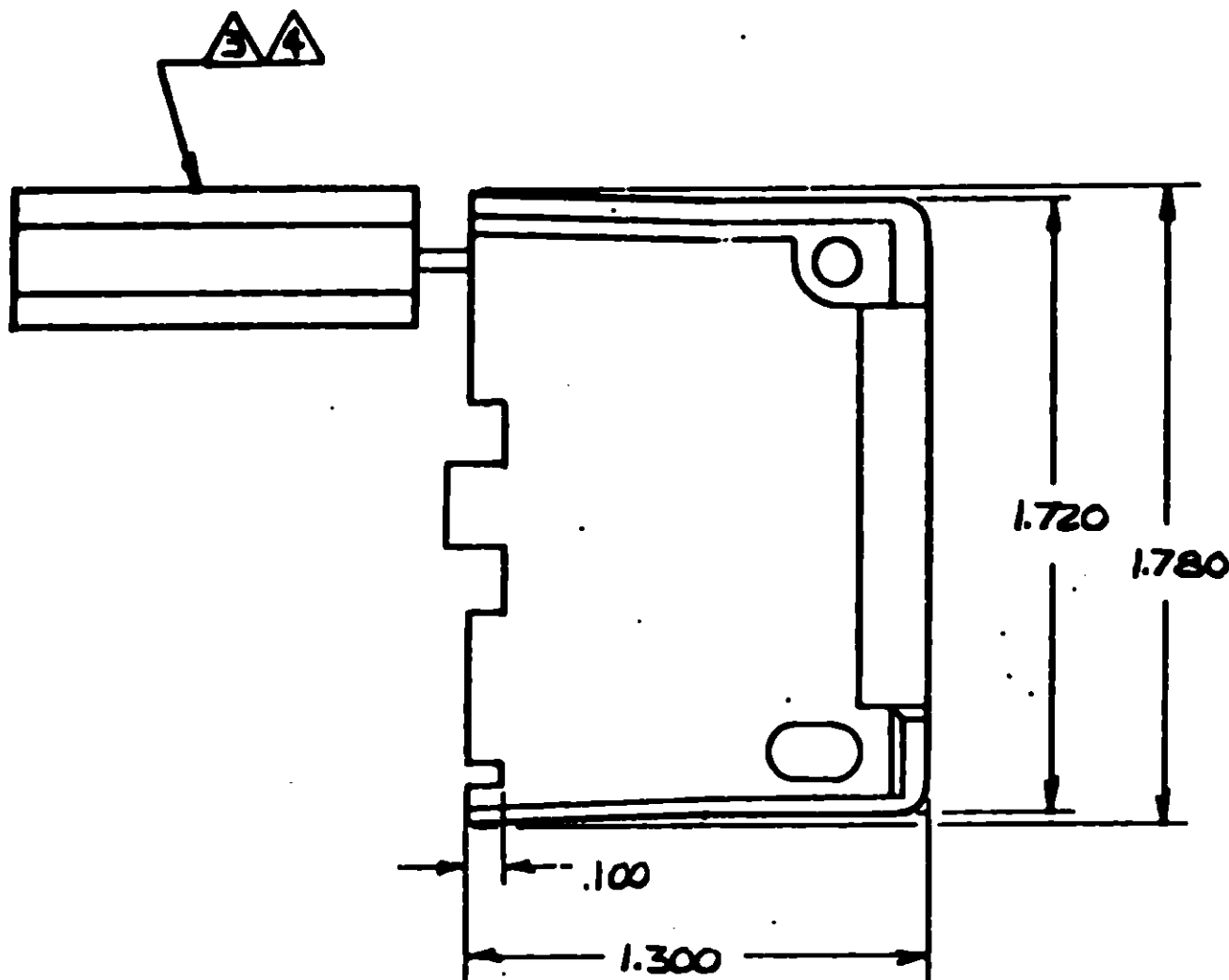
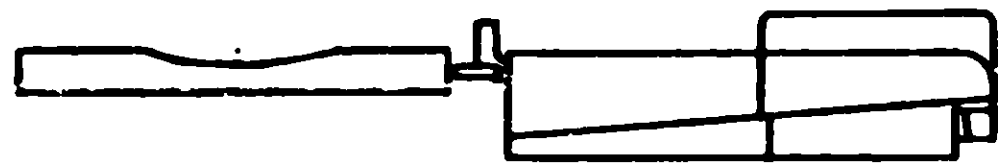

ASSEMBLY DETAILS

- ⚠ SHEET METAL SCREWS NOT SUPPLIED.
- ⚠ TWO REQUIRED PER CONNECTOR.
- ⚠ MAX WIRE BUNDLE WITHOUT INSERT IS 6 AT .190 DIA. AND MIN WIRE BUNDLE WITH INSERT IS 6 AT .040 DIA.
- ⚠ STYLE II DOES NOT INCLUDE INSERT.
- 5. DETACHABLE INSERT MAY SEPARATE FROM STRAIN RELIEF BODY DURING SHIPPING.

MATERIAL	STYLE	COLOR	PART NO.
NYLON94V2	II	NATURAL	643585-2
NYLON94V2	I	NATURAL	643585-1

UNLESS OTHERWISE SPECIFIED DIMENSIONS ARE IN INCHES. TOLERANCES ON: DECIMALS ±.015 ANGLES ±	CONTRACT NO	AMP AMP INCORPORATED Harrisburg, Pa. 17105	
	DR <i>K. White</i> 10-31-83 CHK <i>S. James</i> 11-2-83		
MATERIAL SEE TABLE	APPD <i>B. E. Quillo</i> 11/2/83	SIZE C	FSCM NO 00779
FINISH SEE TABLE	DSGN APPD	DRAWING NO 643585	SCALE 2:1
	OTHER APPD	SHEET 1 OF 1	