

Apr.1.2017 Copyright 2017 HIROSE ELECTRIC CO., LTD. All Rights Reserved.

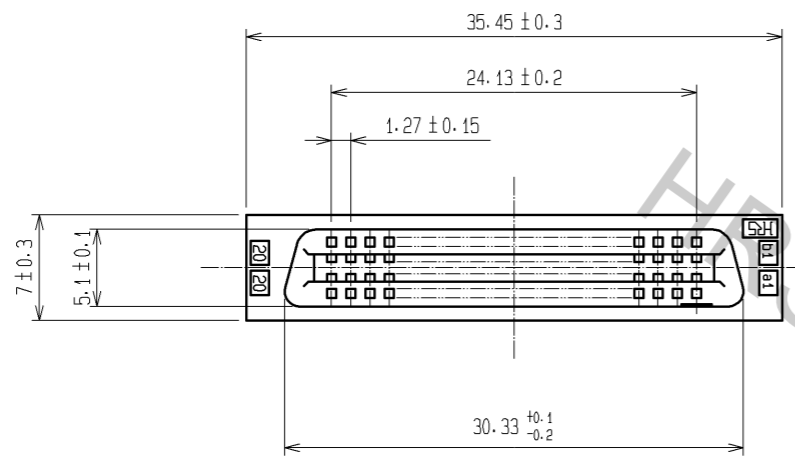

RECOMMENDED PC BOARD HOLE PATTERN
(MOUNTING SIDE) t=1.6

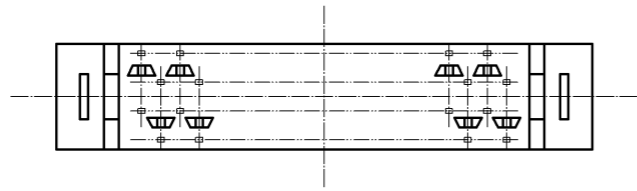
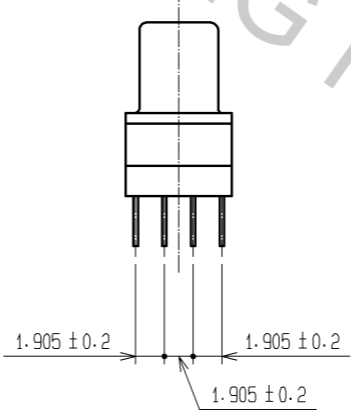
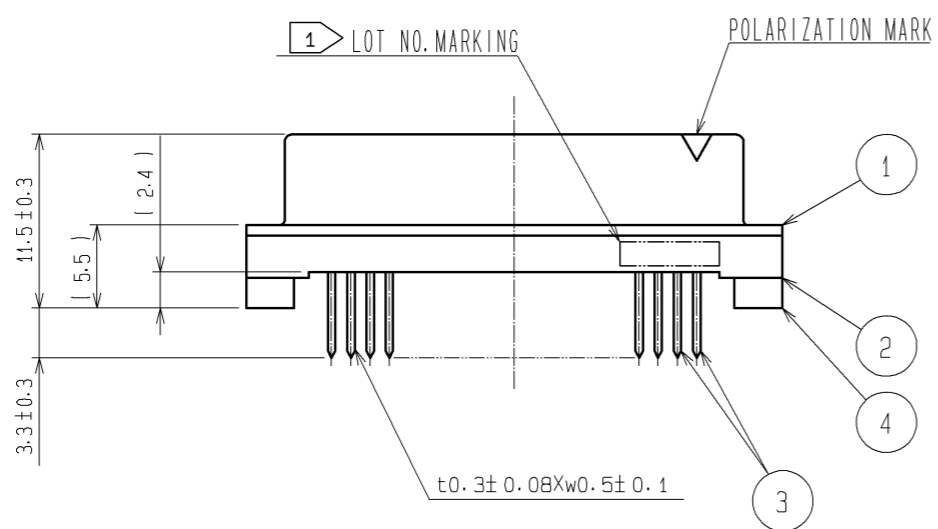
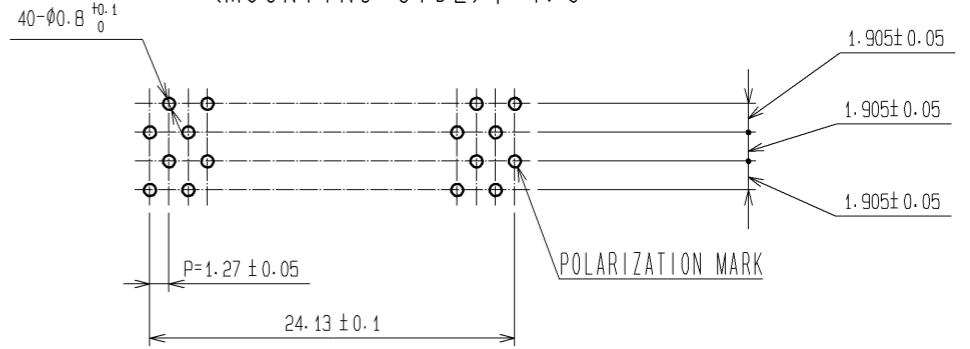

- NOTES 1 LOT NO. MARKING SIDE SHALL BE OPTIONAL.
2. THE DIMENSIONS IN PARENTHESES ARE FOR REFERENCE.

1, 2, 4		POLYAMIDE	BLACK, UL94V-0	3	PHOSPHOR BRONZE	CONTACT AREA : GOLD 0.2 μm min. DIP AREA : TIN-PLATING 2 μm min. UNDER PLATING : NICKEL 2 μm min.
NO.	MATERIAL	FINISH, REMARKS		NO.	MATERIAL	FINISH, REMARKS
UNITS mm		SCALE 2 : 1	COUNT 	DESCRIPTION OF REVISIONS		DESIGNED
		HIROSE ELECTRIC CO., LTD.		APPROVED : HS. OKAWA	07.08.10	DRAWING NO. EDC3-083213-21
				CHECED : HS. OZAWA	07.08.10	PART NO. FX2C2-40S-1.27DSA(71)
				DESIGNED : KY. NAKAMURA	07.08.10	CODE NO. CL572-2423-0-71
				DRAWN : TP. MATSUMOTO	07.08.08	